

Main Index

ETC Index	Index & Updates	A01 - A02
------------------	----------------------------------	-----------

A ETC	Profiles	
	Specification Pages.....	A03 - A06
	Technical Information.....	A07 - A12
	Scale Profile Drawings.....	A13 - A34

B ETC	Accessories	
	Photos & Drawings.....	B03 - B36

C ETC	Sections	
	Scale Elevations.....	C03 - C48

D ETC	Statics	D01 - D02
--------------	----------------------	-----------

E ETC	Construction Drawings	
	Corner Joint Details.....	E03 - E05
	ACET963 Punch Tool.....	E06
	Variable angle Cleats.....	E07
	Bead Notching ACVD916.....	E08
	Drainage.....	E09 - E11
	Angled Sub Cill.....	E12
	Transom/Mullion Fixing Details.....	E13 - E16
	Friction Hinge Details.....	E17 - E19
	ACET4050 Hinge Details.....	E20
	Locking Details.....	E21 - E23
	French Casement Assembly.....	E24 - E25
	Glazing Details.....	E26 - E34
	Bay Pole Options.....	E35 - E36
	Horizontal Coupler Details.....	E37
	Fixing Strap Details.....	E38
	Trickle Vent Details.....	E39

F ETC	Sawing Tables	
	F03 - F08

Updates

DATE	PAGE	DESCRIPTION
Nov. 2023	All	ACET842 changed to ACET841 when using UN3160G ETC4124 slim sash added ACET963 details added Bay pole, frame extension & coupler details updated/expanded ACET4050 hinge added
Jun. 2024	All	ETC4125 slim heritage sash & ETC4137 heritage transom/mullion added 'G' Profile options added to various sections with additional tooling UN3570 Trickle vent added
Aug. 2024	All	ETC4110, ETC4112 & ETC4120 Cleat chambers revised to accept ACET820 cleat.

Specification

GENERAL DESCRIPTION

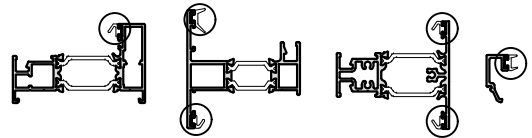
The "Alitherm 400" window system described in this manual is suitable for both replacement windows for existing buildings and for installation into new buildings.

The system incorporates internally & externally beaded vent frames suitable for espag locking.

The low line gaskets and extended polyamide thermal breaks help to provide excellent U Values and Window Energy Rating capable of achieving an 'A' Rating when used in conjunction with the correct double glazed unit.

Alitherm 400 has the option of Quick-Glaze beads with integrated gasket, providing a fast and efficient glazing process. Non integrated gasket options are also available.

Profiles with a 'G' suffix are supplied with integrated gasket.



PROFILE SPECIFICATION

The window frames are constructed of aluminium alloy extrusion to BS EN 755-9 and BS EN 12020, extruded to 6063 T6 alloy. The internal and external extrusions are separated with a polyamide thermal break.

The external aluminium alloy extrusion is pre-treated and finished either:-

- a) Anodised to BS 3987: 1987, grade AA25 to a natural self colour.
- b) Polyester powder organic coating to BS 6496. Dual colour is available.

GENERAL MANUFACTURING

Outer and vent frames are made by cutting the frame profiles with accurate 45° mitred ends using Tungsten Carbide Tipped Saw Blades, operating at approximately 3000 rpm.

The corners are joined using the Alitherm 400 crimping tools to form a cold forged corner joint (made by deforming small slugs of metal into the groove of the corner cleat).

The ends of transoms and mullions are profiled to fit the frame and fixed using self-tapping screws with a silicone seal.

On polyester powder coated finishes, great care should be taken to avoid getting gap sealer on visible surfaces and should be removed as soon as possible with a clean cloth.

Care should be exercised when using products not supplied by Smart Systems Ltd as no responsibility can be accepted.

Specification

WINDOW DRAINAGE

As with all dry glazed systems, it is recommended that the window system is adequately drained and ventilated. Refer to drainage details in manual, if in doubt ask The Technical Department.

In order to get maximum performance and weather resistance it is recommended that drips are used over all vents.

OUTER FRAME MANUFACTURING INFORMATION

The outer frame members are cut with 45° mitred ends to the overall size required, measured to the longest point of the metal.

Prior to corner crimping the centre line position of any transoms or mullions should be marked on the outer frame members. Where the transom/mullion runs right through, it should be marked out on both jambs or head and cill members in pairs to ensure accurate alignment of the sections.

Using the marked centre line, Drill the transom/mullion fixing holes using a 5mm dia. drill bit.

Corners are formed by coating the cut faces to be joined with a suitable small gap sealer. Into the mitred corner insert the cleat glue and the required corner cleats and, where required, the aluminium corner chevrons. The two mitred ends are then brought together and crimped. The small gap sealer ensures a permanent joint and guards against the ingress of moisture and joint movement. After crimping the corner joint, special care should be taken to ensure any excess sealer is removed from painted surfaces.

Transoms or mullions are cut with square ends to the sizes calculated on the cutting formula sheets. The ends are then profiled to allow them to fit into the outer frame. Special tooling is available on request to profile the end of transom/mullion.

Prior to fixing of transoms and mullions smear the cut ends with a suitable gap sealer. After fixing, special care should be taken to ensure any excess is cleared from painted surfaces.

PROFILES WITH INTEGRATED GASKET

When cutting profiles with integrated gaskets, it is crucial to use sharp, well-maintained saw blades to ensure clean cuts.

For optimal mitre cuts, position the profiles so the gasket channels face the saw blades. However, we recommend testing different profile orientations on your saw to determine the best cutting method.

Transoms and mullions with integrated gaskets can be end milled as standard.

Specification

MULTI-POINT LOCKING

The vent should be prepped for the locking mechanism prior to fabrication and fitted into vent before hanging. Stainless steel fixings shall be used for securing the locking mechanism and keeps in position.

GLAZING

All beads are cut to suit the glazing aperture on the fully assembled window for glazing either at factory or on site as required.

EXTERNALLY BEADED GLAZING

Glazing beads are fitted to openings by cutting the horizontal beads square to head and cill of each vent and fixed light area. Vertical beads are cut squared at both ends. Insert bottom beads and two setting blocks to ensure glass will be centralized in vertical dimension of opening (glazing blocks must be full width of cavity to fully support glass or sealed unit), then insert top bead followed by side beads. Finish glazing by insertion of internal gaskets all round.

INTERNALLY BEADED GLAZING

Glazing beads are fitted to openings by cutting the horizontal beads square to head and cill of each vent and fixed light area. Vertical beads are cut square at both ends. Insert bottom beads and two setting blocks to ensure glass will be centralized in vertical dimension of opening (glazing blocks must be full width of cavity to fully support glass or sealed unit), then insert top bead followed by side beads. Finish glazing by insertion of internal gaskets all round.

When glazing with the Quick-Glaze bead, using a glass adjuster is strongly advised to adjust the glazing accordingly with ease.

Specification

Kitemark™ Certificate

No. KM 81580

Size Limitations and Performance Characteristics

Alitherm 400 Aluminium Alloy Window System

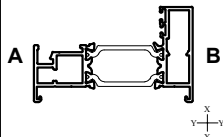
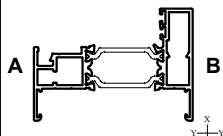
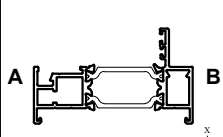
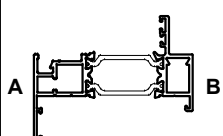
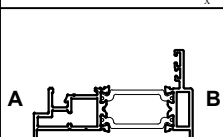
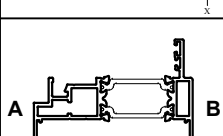
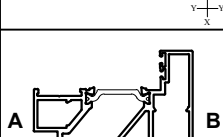
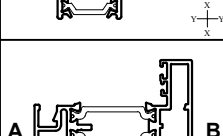
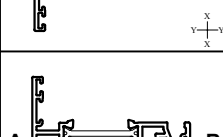
Window Type	Width (mm) Maximum	Height (mm) Maximum	Weight (kg) Maximum	Area (M ²) Maximum	Friction Stays (up to and including)	Transom/Mullion Length (mm) inc frame - Maximum	Air Permeability classification	Water tightness classification	Resistance to Wind classification	Exposure category as given in Table 1 of BS 6375-1:2009
Sash dimensions for windows with approved sash profiles:										
Projecting top hung Internally beaded	1400	1400	40	-	24"	-	4	7A	AE2400	2000+
Projecting top hung Externally beaded	1400	1400	40	-	24"	-	4	5A	AE2400	2000+
Projecting side hung Internally beaded	600	1400	28	-	16"	-	4	7A	AE2400	2000+
Projecting side hung Externally beaded	600	1400	28	-	16"	-	4	5A	AE2400	2000+
Overall dimensions for windows with approved outer frame profiles:										
Fixed Internally Beaded	2100	2100	-	4.2	-	-	4	7A	AE2400	2000+
Fixed Externally Beaded	2100	2100	-	4.2	-	-	4	5A	AE2400	2000+
Overall dimensions for approved outer frames & transom/mullion profiles:										
Multilights* Internally Beaded	2100	2100	-	2.5	-	1200	4	7A	AE2400	2000+
Multilights* Externally Beaded	2100	2100	-	2.5	-	1200	4	5A	AE2400	2000+

*Transom/mullion subject to lxx/lyy requirements

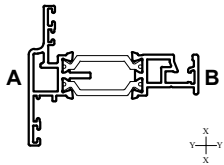
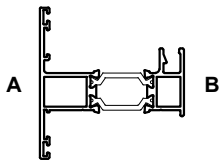
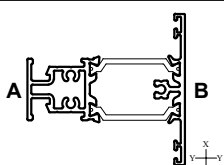
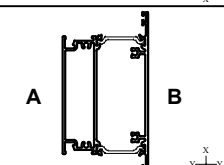
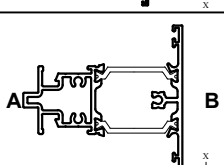
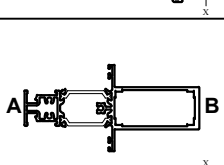
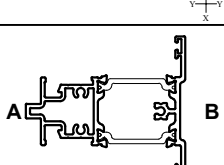
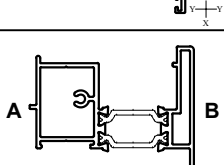
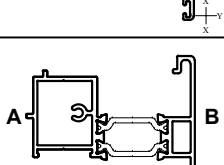
Please see pages B25 & B26 for more guidance on vent sizes & limitations.

- Side Hung Weight Limit Can Be Increased To 40 kg Using Egress Hinges
- See hardware for minimum and maximum sizes

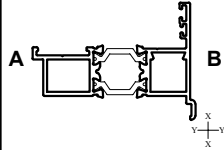
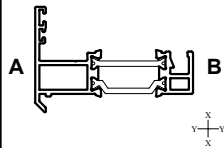
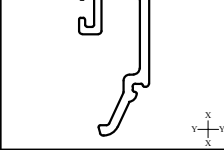
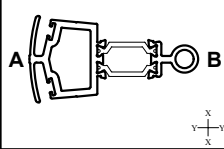
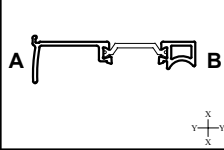
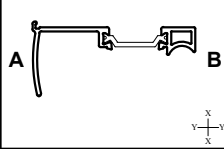
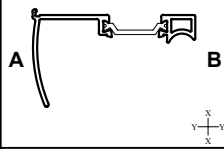
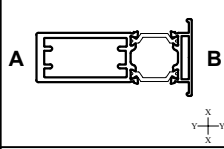
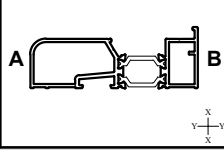
PROFILES : TECHNICAL INFORMATION

Number	Picture	Page	Perim. mm	Mec. mm	lx(cm4) wx(cm3)	ly(cm4) wy(cm3)	Length	Pack pr.	MF	SA	KL	HP	M
ETC4110 ETC4110G		A13	295	82	23.98 --- 6.16	4.12 --- 2.23	6.5	1	✓	✓	✓	✓	✓
ETC4111 ETC4111G		A13	346	97	26.73 --- 6.91	5.28 --- 2.14	6.5	1	✓	✓	✓	✓	✓
ETC4112 ETC4112G		A14	297	78	21.54 --- 6.47	2.74 --- 1.64	6.5	1	✓	✓	✓	✓	✓
ETC4113		A14	371	101	27.56 --- 7.8	5.91 --- 2.18	6.5	1	✓	✓	✓	✓	✓
ETC4115 ETC4115G		A15	297	78	21.50 --- 5.69	2.75 --- 1.68	6.5	1	✓	✓	✓	✓	✓
ETC4116 ETC4116G		A15	351	96	26.38 --- 6.61	4.39 --- 1.93	6.5	1	✓	✓	✓	✓	✓
ETC4117		A16	391	76	26.4 --- 7.14	11.73 --- 3.90	6.5	1	✓	✓	✓	✓	✓
ETC4120 ETC4120G		A16	297	87	18.24 --- 6.10	4.63 --- 1.95	6.5	1	✓	✓	✓	✓	✓
ETC4124 ETC4124G		A17	346	72	14.37 --- 3.88	2.75 --- 1.13	6.5	1	✓	✓	✓	✓	✓
									B = Inside		SA = Silver Anodised KL = Basic Colour HP = Special Colour M = Dual Colour		

PROFILES : TECHNICAL INFORMATION

Number	Picture	Page	Perim. mm	Mec. mm	lx(cm4) wx(cm3)	ly(cm4) wy(cm3)	Length	Pack pr.	MF	SA	KL	HP	M	
ETC4125 ETC4125G		A17	344	79	13.93 --- 3.77	2.84 --- 1.18	6.5	1	✓	✓	✓	✓	✓	
ETC4129 ETC4129G		A18	335	99	19.34 --- 5.51	5.91 --- 1.95	6.5	1	✓	✓	✓	✓	✓	
ETC4130 ETC4130G		A19	312	89	19.39 --- 5.84	4.66 --- 1.63	6.5	1	✓	✓	✓	✓	✓	
ETC4131		A34	427	213	93.65 --- 16.15	43.02 --- 16.42	6.5	1	✓	✓	✓	✓	✓	
ETC4135 ETC4135G		A20	337	111	23.74 --- 6.30	6.51 --- 2.11	6.5	1	✓	✓	✓	✓	✓	
ETC4136		A20	421	201	95.03 --- 15.97	9.13 --- 3.21	6.5	1	✓	✓	✓	✓	✓	
ETC4137 ETC4137G		A20	410	113	23.74 --- 6.30	6.51 --- 2.11	6.5	1	✓	✓	✓	✓	✓	
ETC4138		A21	306	83	20.06 --- 5.62	7.04 --- 2.88	6.5	1	✓	✓	✓	✓	✓	
ETC4139		A21	340	84	19.48 --- 5.40	6.55 --- 2.54	6.5	1	✓	✓	✓	✓	✓	
									B = Inside		SA = Silver Anodised KL = Basic Colour HP = Special Colour M = Dual Colour			

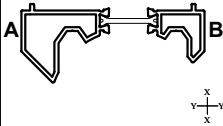
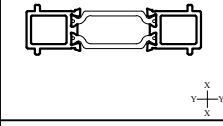
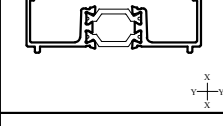
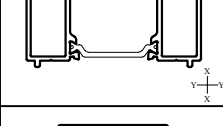

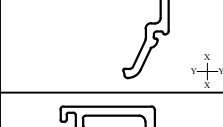
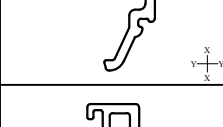
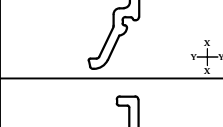

PROFILES : TECHNICAL INFORMATION

Number	Picture	Page	Perim. mm	Mec. mm	lx(cm4) wx(cm3)	ly(cm4) wy(cm3)	Length	Pack pr.	MF	SA	KL	HP	M	
ETC4146		A22	248	74	12.60 --- 3.50	2.64 --- 1.35	6.5	1	✓	✓	✓	✓	✓	
ETC4147		A22	256	65	13.69 --- 3.89	2.00 --- 1.22	6.5	1	✓	✓	✓	✓	✓	
ETC4179 ETC4179G		A24	104	29	- --- -	- --- -	6.5	1	✓	✓	✓	✓		
ETC080		A29	334	61	25.58 --- 5.47	4.88 --- 2.57	6.5	1	✓	✓	✓	✓	✓	
ETC081		A29	197	35	13.85 --- 3.8	0.36 --- 0.52	6.5	1	✓	✓	✓	✓	✓	
ETC082		A29	221	47	16.21 --- 4.19	1.15 --- 1.29	6.5	1	✓	✓	✓	✓	✓	
ETC083		A29	243	58	17.66 --- 4.32	2.64 --- 2.36	6.5	1	✓	✓	✓	✓	✓	
ETC357		A30	297	138	41.5 --- 9.86	52 --- 2.67	6.5	1	✓	✓	✓	✓	✓	
ETC451		A31	304	109	32.44 --- 7.29	3.46 --- 2.79	6.5	1	✓	✓	✓	✓	✓	
									A = Outside B = Inside		MF = Mill Finish SA = Silver Anodised KL = Basic Colour HP = Special Colour M = Dual Colour			

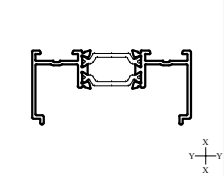
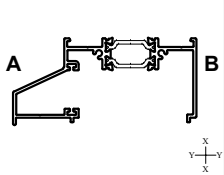
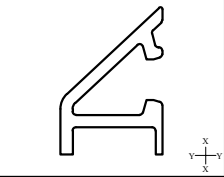
PROFILES : TECHNICAL INFORMATION

Number	Picture	Page	Perim. mm	Mec. mm	lx(cm4) wx(cm3)	ly(cm4) wy(cm3)	Length	Pack pr.	MF	SA	KL	HP	M	
ETC452		A31	414	197	122.46 --- 18.03	6.01 --- 3.34	6.5	1	✓	✓	✓	✓	✓	
ETC457		A31	444	212	164.27 --- 21.60	6.79 --- 3.73	6.5	1	✓	✓	✓	✓	✓	
ETC458		A32	524	252	313.62 --- 32.63	8.87 --- 4.79	6.5	1	✓	✓	✓	✓	✓	
ETC477		A33	752	408	1591.6 --- 105.33	26.84 --- 12.84	6.5	1	✓	✓	✓	✓	✓	
ETC479N		A32	594	287	501.64 --- 44.04	9.72 --- 5.34	6.5	1	✓	✓	✓	✓	✓	
ETC869		A26	332	144	18.38 --- 6.13	14.3 --- 5.17	6.5	1	✓	✓	✓	✓	✓	
UN3000		A30	251	41	15.8 --- 4.51	0.79 --- 0.84	6.5	1	✓	✓	✓	✓	✓	
UN3010		A28	369	226	41.4 --- 10.7	40.0 --- 11.6	6.5	1	✓	✓	✓	✓	✓	
UN3011		A28	288	130.3	22.3 --- 5	12.2 --- 4.1	6.5	1	✓	✓	✓	✓	✓	
									A = Outside B = Inside		MF = Mill Finish SA = Silver Anodised KL = Basic Colour HP = Special Colour M = Dual Colour			

PROFILES : TECHNICAL INFORMATION

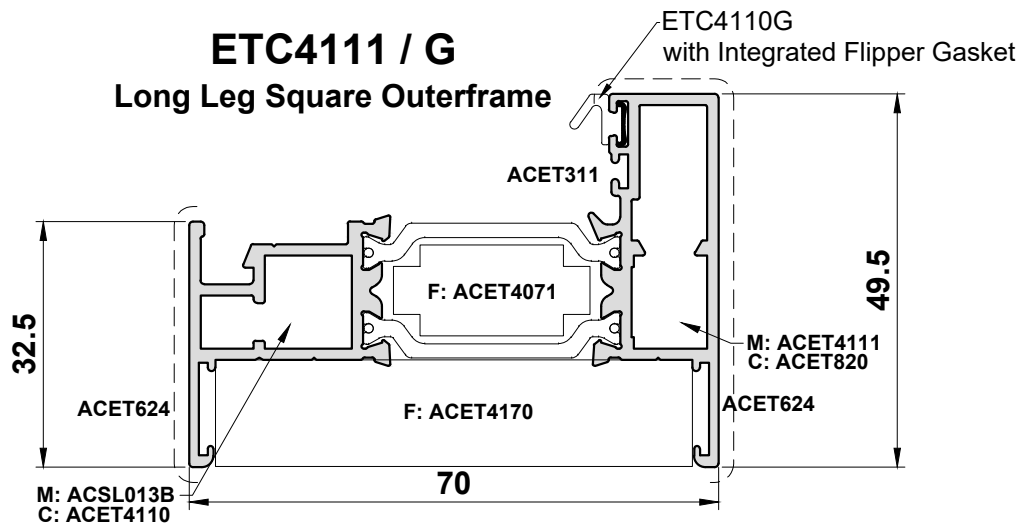
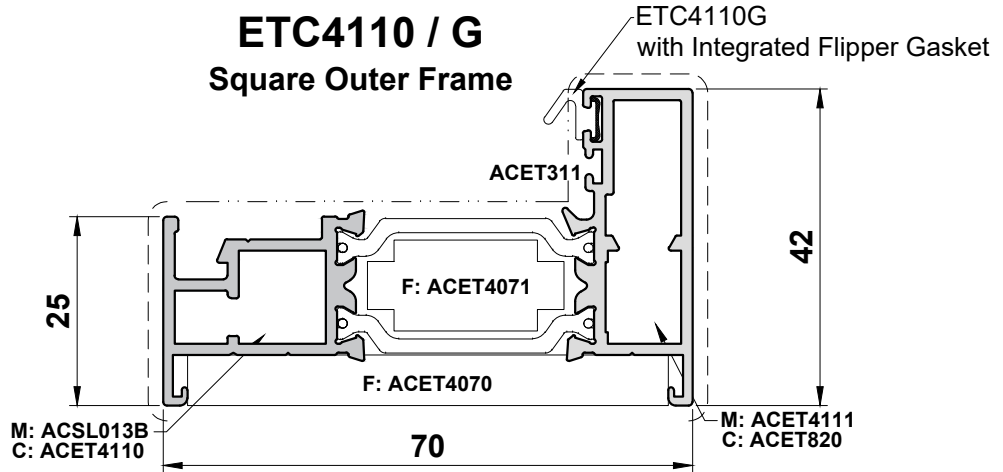
Number	Picture	Page	Perim. mm	Mec. mm	lx(cm4) wx(cm3)	ly(cm4) wy(cm3)	Length	Pack pr.	MF	SA	KL	HP	M	
UN3012		A26	238	76	1.53 --- 0.79	17.24 --- 5.09	6.5	1	✓	✓	✓	✓	✓	
UN3015		A30	214.5	56	18.1 --- 5.2	1 --- 1	6.5	1	✓	✓	✓	✓	✓	
UN3020		A27	281.6	70.4	14.8 --- 4.2	0.9 --- 1	6.5	1	✓	✓	✓	✓		
UN3042		A27	288	111	31.2 --- 8.9	9.5 --- 4.3	6.5	1	✓	✓	✓	✓	✓	
UN3160 UN3160G		A23	120	39	- --- -	- --- -	6.5	1	✓	✓	✓	✓		
UN3162N UN3162G		A23	128	41	- --- -	- --- -	6.5	1	✓	✓	✓	✓		
UN3164 UN3164G		A24	112	33	- --- -	- --- -	6.5	1	✓	✓	✓	✓		
UN3166		A25	98	43	- --- -	- --- -	6.5	1	✓	✓	✓	✓		
UN3168		A25	65	23	- --- -	- --- -	6.5	1	✓	✓	✓	✓		
									A = Outside B = Inside		MF = Mill Finish SA = Silver Anodised KL = Basic Colour HP = Special Colour M = Dual Colour			

PROFILES : TECHNICAL INFORMATION

Number	Picture	Page	Perim. mm	Mec. mm	Ix(cm4) wx(cm3)	Iy(cm4) wy(cm3)	Length	Pack pr.	MF	SA	KL	HP	M	
UN3370		A27	360	61	18.4 --- 5.26	2.15 --- 1.97	6.5	1	✓	✓	✓	✓	✓	
UN3570		A34	545	140	47.47 --- 9.53	9.26 --- 4.87	6.5	1	✓	✓	✓	✓	✓	
UN079 (VL72)		A26	251	41	16.30 --- 4.66	1.12 --- 1.55	6.5	1	✓	✓	✓	✓		
									A = Outside B = Inside		MF = Mill Finish SA = Silver Anodised KL = Basic Colour HP = Special Colour M = Dual Colour			

Primary Visible Side

Secondary Visible Side

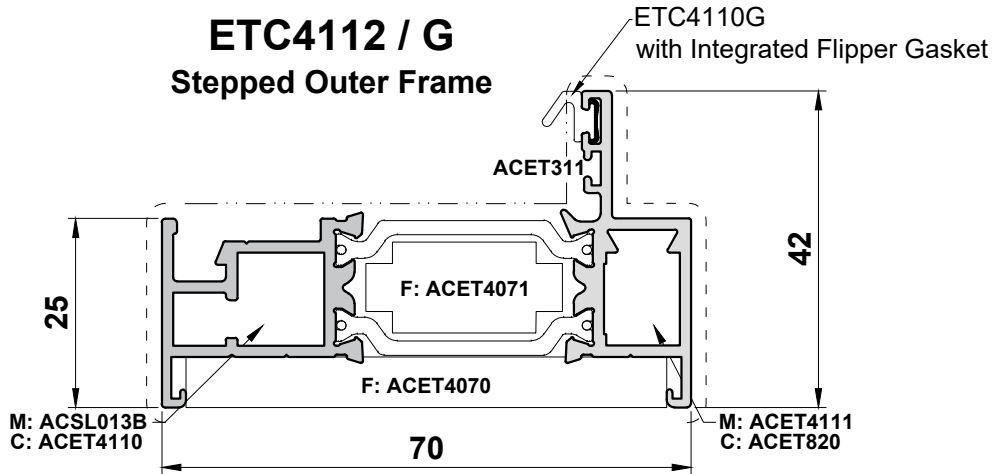


Scale 1:1

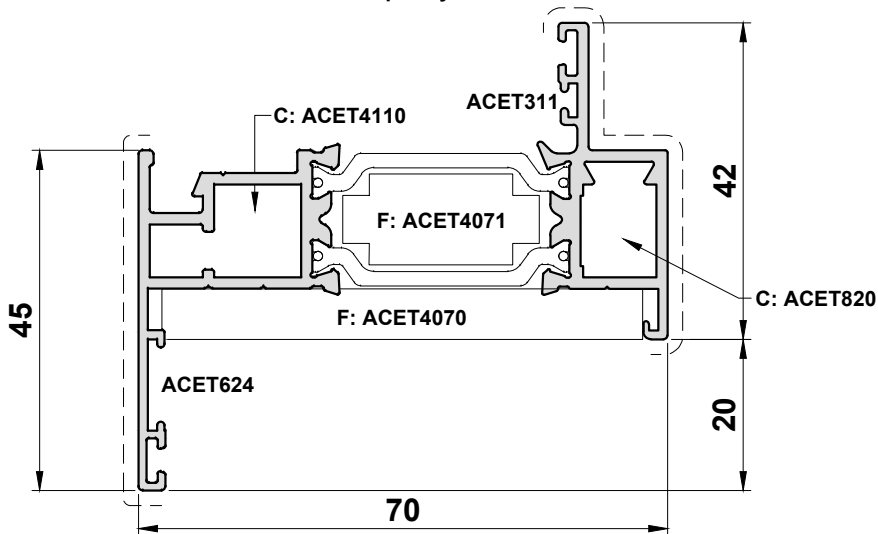
Primary Visible Side

Secondary Visible Side

ETC4112 / G
Stepped Outer Frame



ETC4113
Odd Leg Stepped Outerframe
Crimp Only

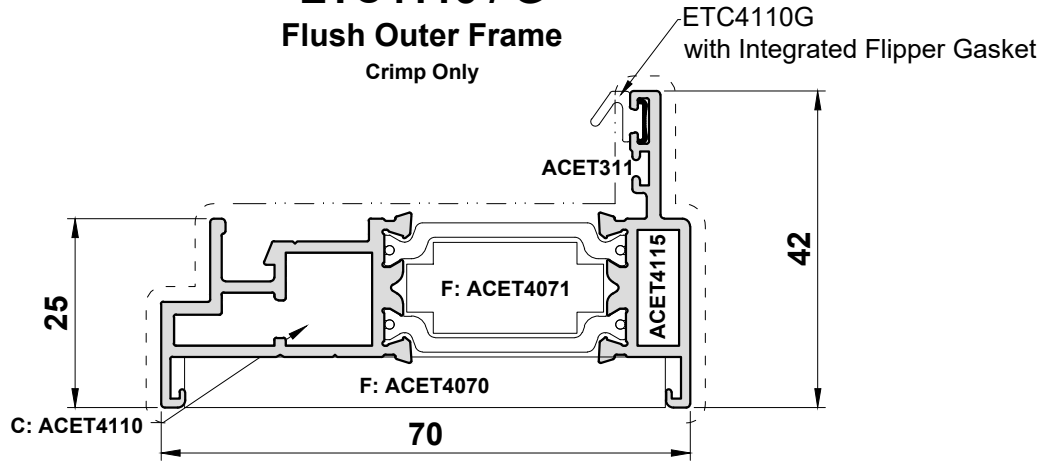


Scale 1:1

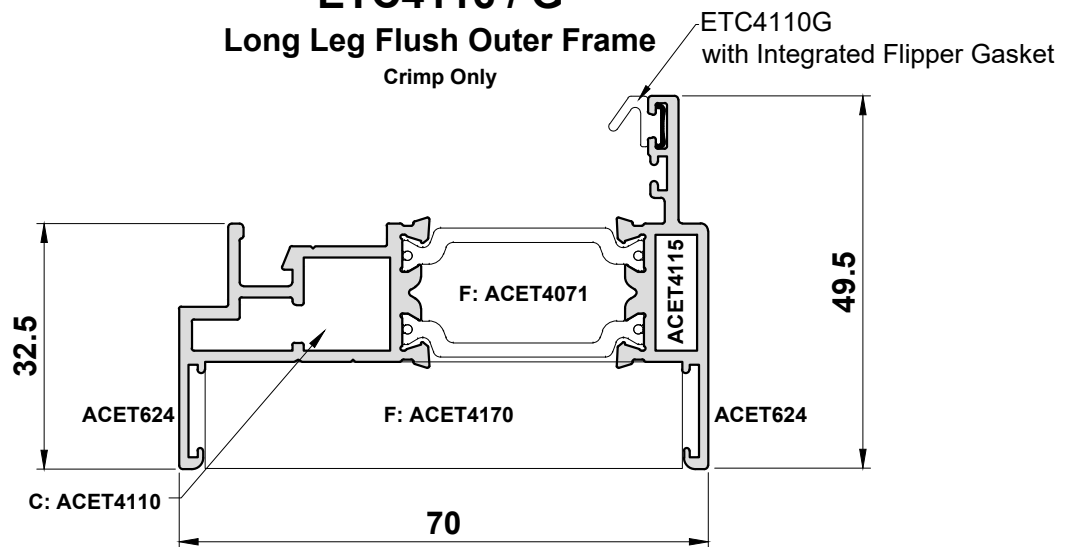
Primary Visible Side

Secondary Visible Side

ETC4115 / G
Flush Outer Frame
Crimp Only



ETC4116 / G
Long Leg Flush Outer Frame
Crimp Only



Scale 1:1

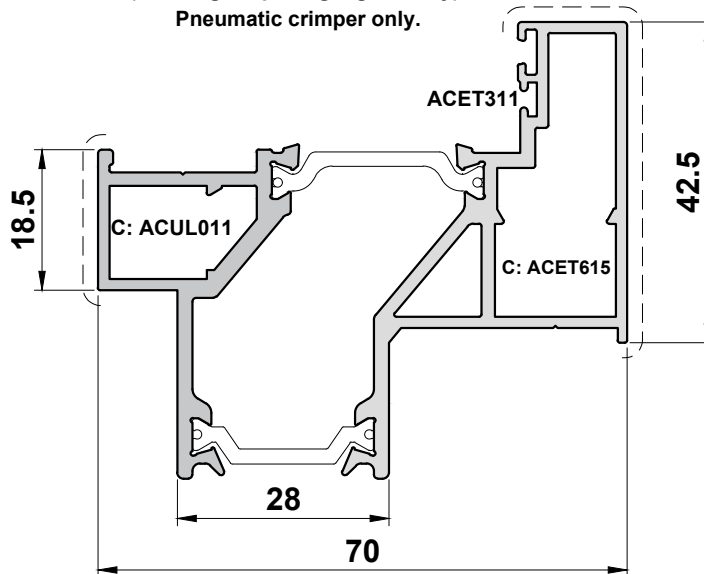
Primary Visible Side

Secondary Visible Side

ETC4117

Curtain Wall Adaptor

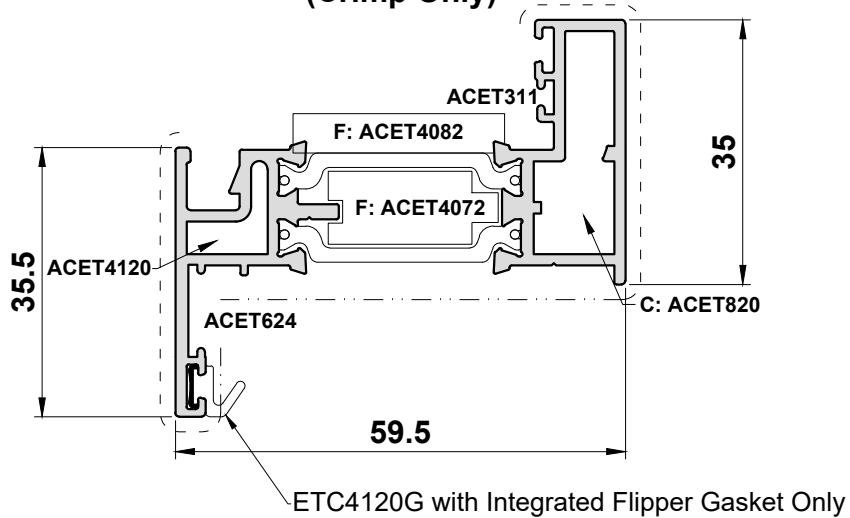
(For Single Opening Lights Only)
Pneumatic crimper only.



ETC4120 / G

Externally Beaded Sash

(Crimp Only)

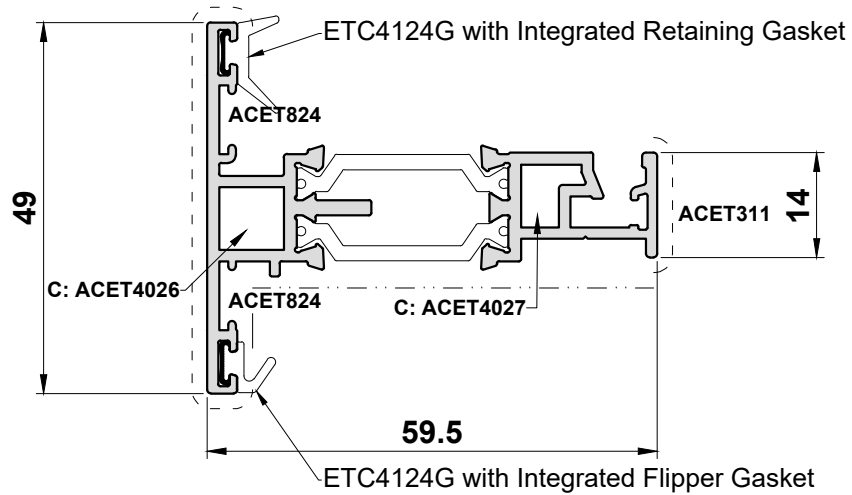


Scale 1:1

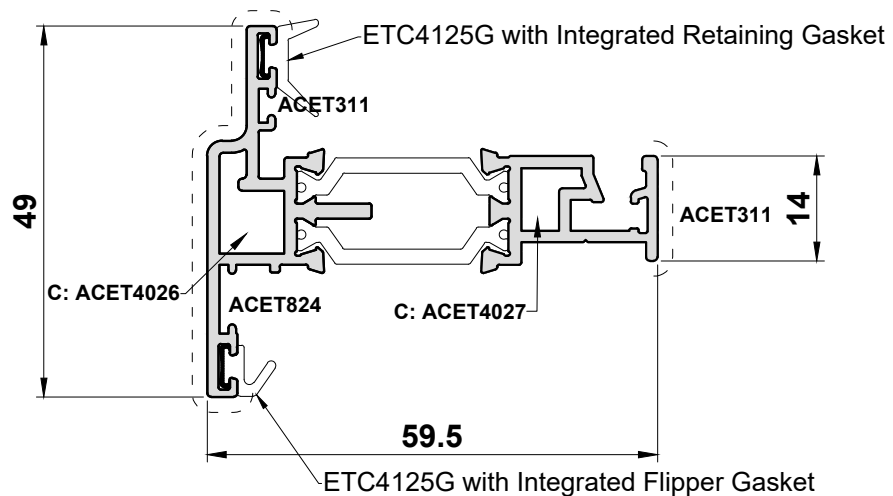
Primary Visible Side

Secondary Visible Side

ETC4124 / G
Slimline Sash



ETC4125 / G
Heritage Sash
for 24mm Glazing Only

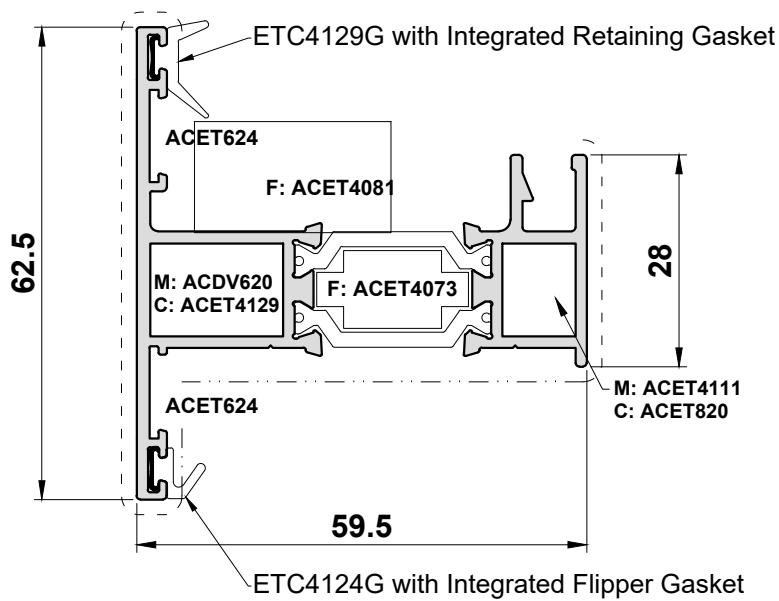


Scale 1:1

Primary Visible Side

Secondary Visible Side

ETC4129 / G Internally Bead Sash

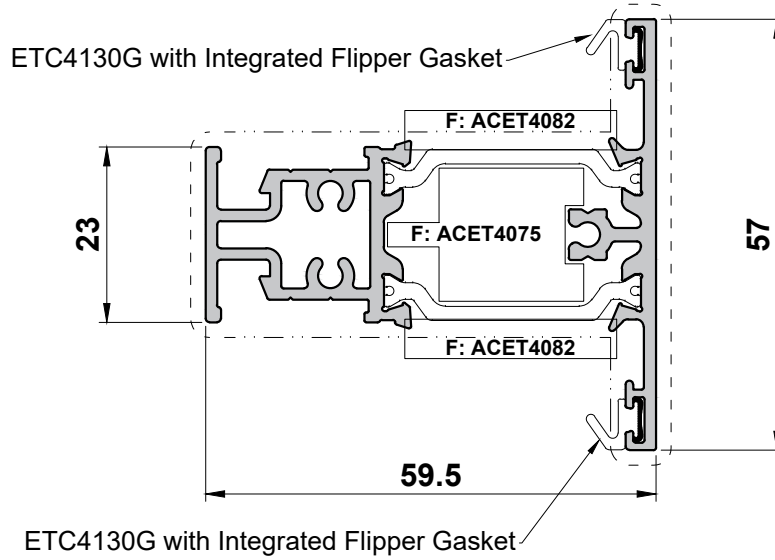


Scale 1:1

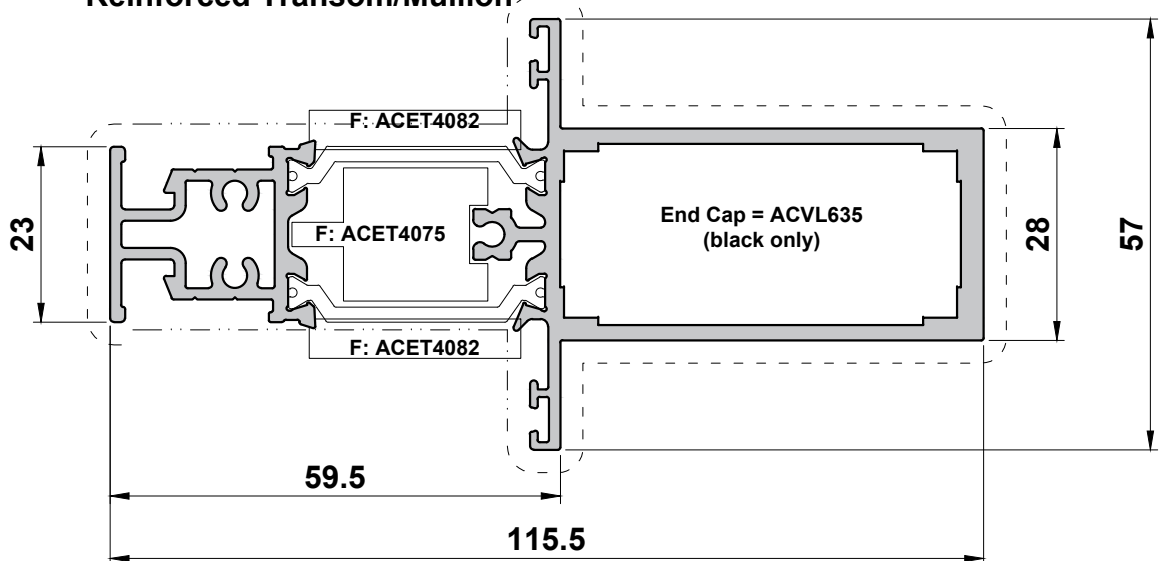
Primary Visible Side

Secondary Visible Side

ETC4130 / G
Transom/Mullion



ETC4136
Reinforced Transom/Mullion

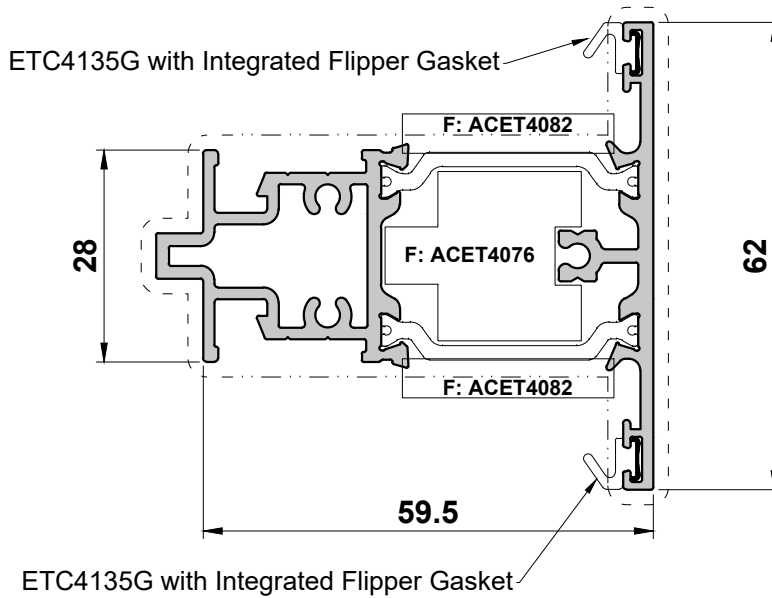


Scale 1:1

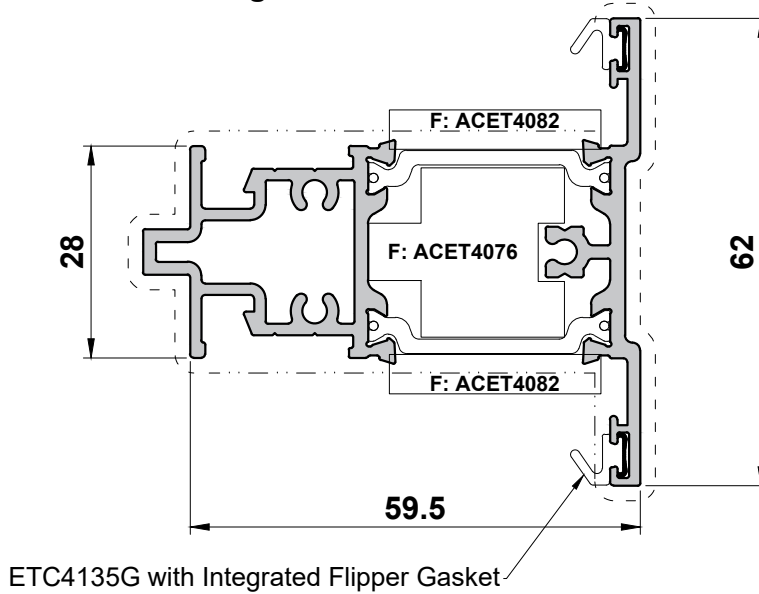
Primary Visible Side

Secondary Visible Side

ETC4135 / G
Flush Transom/Mullion



ETC4137 / G
Heritage Flush Transom/Mullion

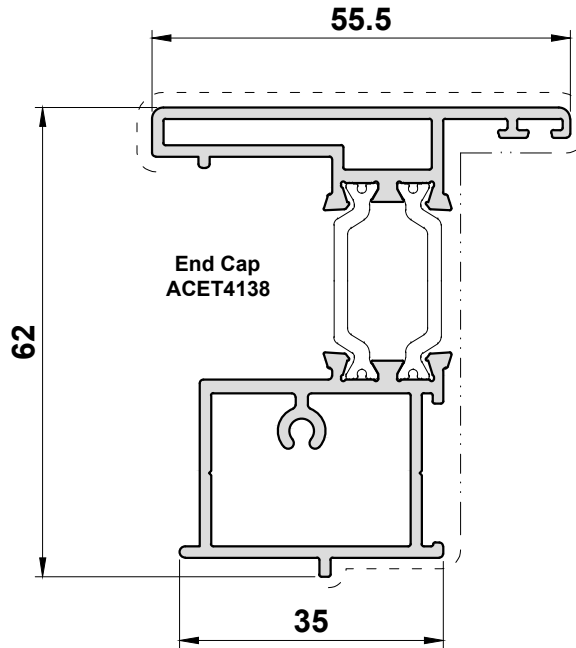


Scale 1:1

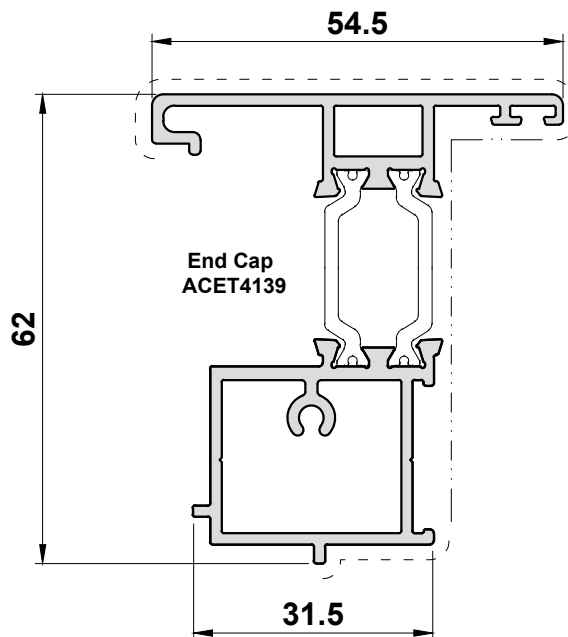
Primary Visible Side

Secondary Visible Side

ETC4138
French Casement Mullion



ETC4139
French Casement Mullion
for Slimline Sash ETC4124 & ETC4125

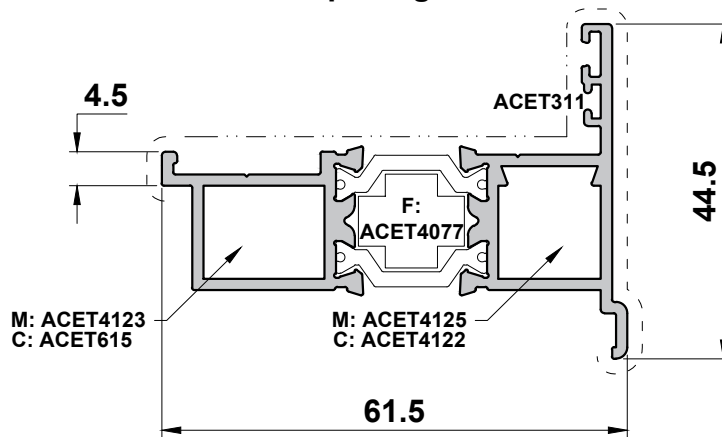


Scale 1:1

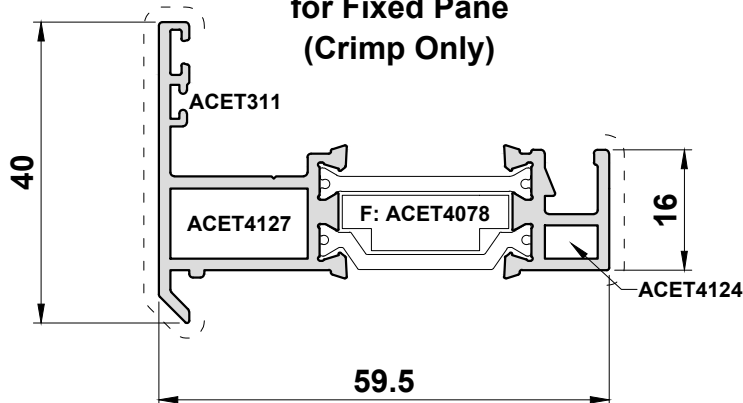
Primary Visible Side

Secondary Visible Side

ETC4146
Reverse Adaptor
for Opening Sash



ETC4147
Reverse Adaptor
for Fixed Pane
(Crimp Only)



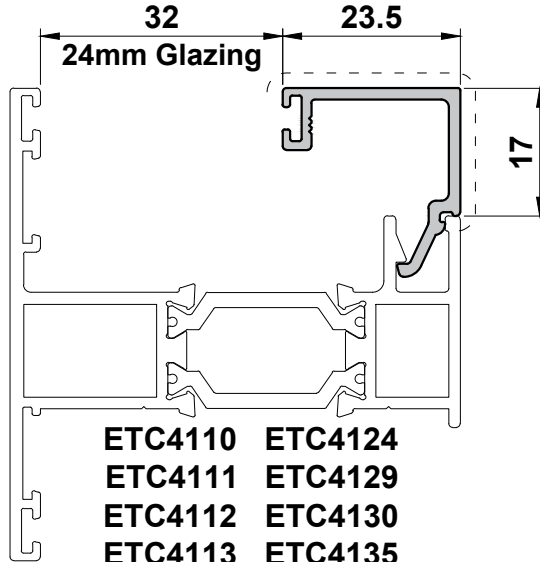
Scale 1:1

Primary Visible Side

Secondary Visible Side

UN3162N

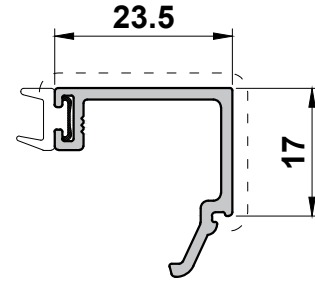
23.5mm Bead



- | | |
|---------|---------|
| ETC4110 | ETC4124 |
| ETC4111 | ETC4129 |
| ETC4112 | ETC4130 |
| ETC4113 | ETC4135 |
| ETC4115 | ETC4136 |
| ETC4116 | ETC4147 |

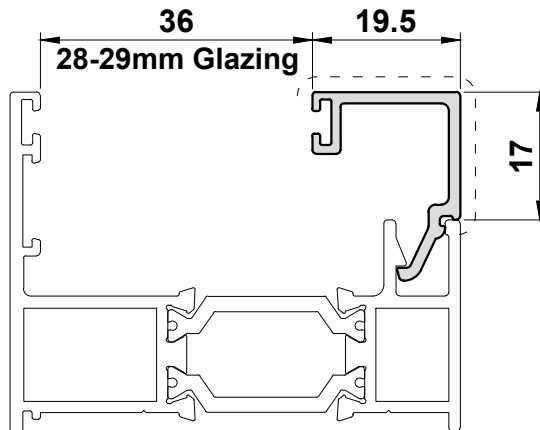
UN3162G

23.5mm Bead
with Gasket



UN3160

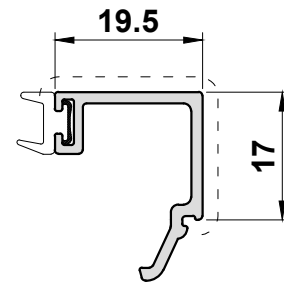
19.5mm Bead



- | | |
|---------|------------------------|
| ETC4110 | ETC4124 |
| ETC4111 | ETC4125 (24mm glazing) |
| ETC4112 | ETC4129 |
| ETC4113 | ETC4130 |
| ETC4115 | ETC4135 |
| ETC4116 | ETC4136 |
| | ETC4147 |

UN3160G

19.5mm Bead
with Gasket



See Section E glazing chart for ETC4120 glazing details

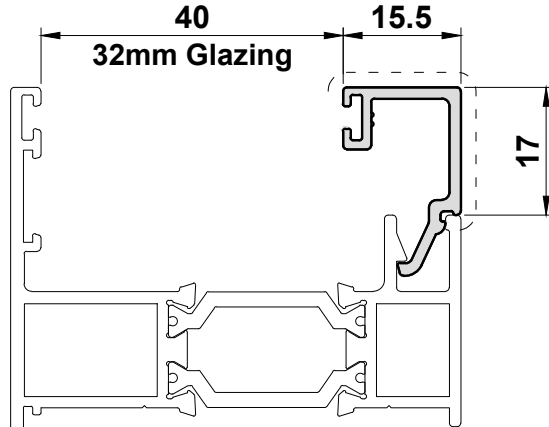
Scale 1:1

Primary Visible Side

Secondary Visible Side

UN3164

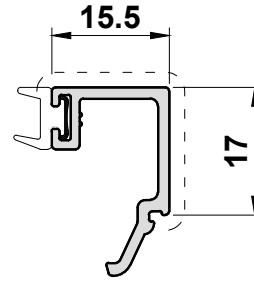
15.5mm Bead



- ETC4110 ETC4124
- ETC4111 ETC4129
- ETC4112 ETC4130
- ETC4113 ETC4135
- ETC4115 ETC4136
- ETC4116 ETC4147

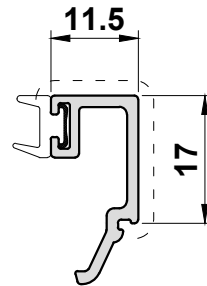
UN3164G

15.5mm Bead with Gasket



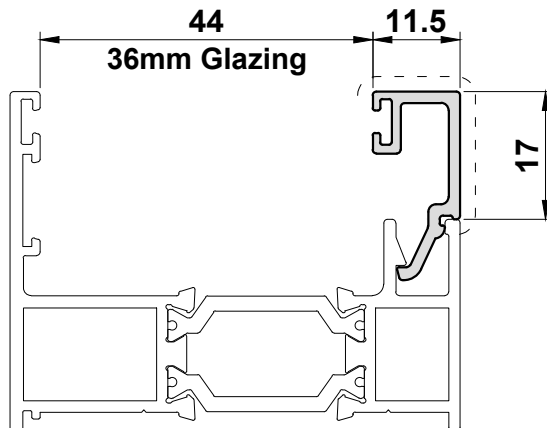
ETC4179G

11.5mm Bead with Gasket



ETC4179

11.5mm Bead



- ETC4110 ETC4124
- ETC4111 ETC4129
- ETC4112 ETC4130
- ETC4113 ETC4135
- ETC4115 ETC4136
- ETC4116 ETC4147

Scale 1:1

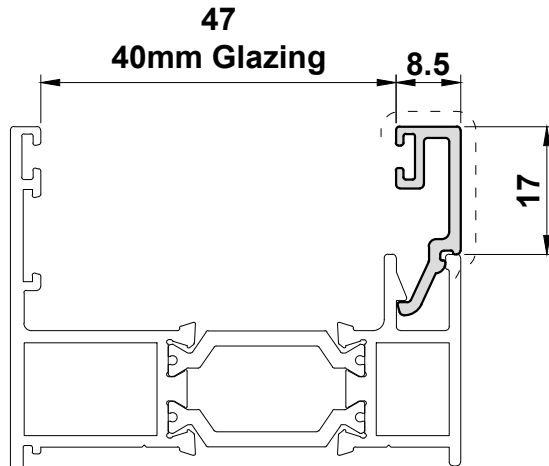
See Section E glazing chart for ETC4120 glazing details

Primary Visible Side

Secondary Visible Side

UN3166

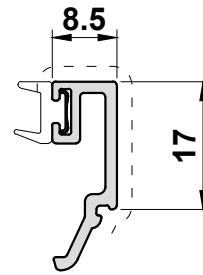
8.5mm Bead



- | | |
|---------|---------|
| ETC4110 | ETC4124 |
| ETC4111 | ETC4129 |
| ETC4112 | ETC4130 |
| ETC4113 | ETC4135 |
| ETC4115 | ETC4136 |
| ETC4116 | ETC4147 |

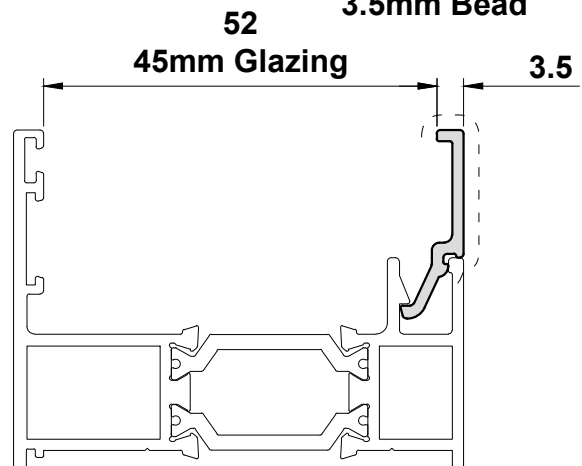
UN3166G

8.5mm Bead
with Gasket



UN3168

3.5mm Bead



- | | |
|---------|---------|
| ETC4110 | ETC4124 |
| ETC4111 | ETC4129 |
| ETC4112 | ETC4130 |
| ETC4113 | ETC4135 |
| ETC4115 | ETC4136 |
| | ETC4147 |

See Section E glazing chart for ETC4120 glazing details

Scale 1:1

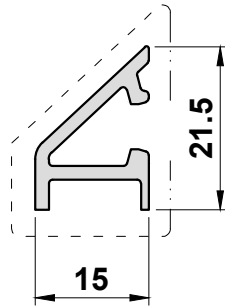
Primary Visible Side

Secondary Visible Side

UN079 (VL72)

Drip / Weather Bar

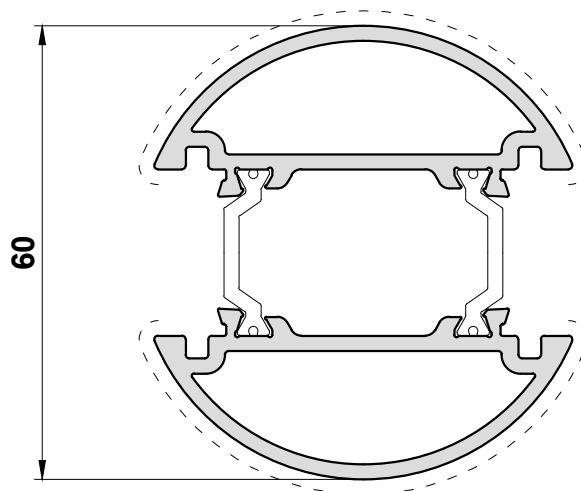
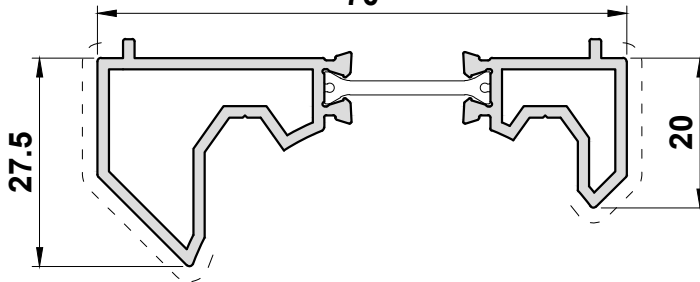
End Caps: ACVL059



UN3012

Bay Pole Adaptor

70



ETC869

Ø60mm Bay Pole

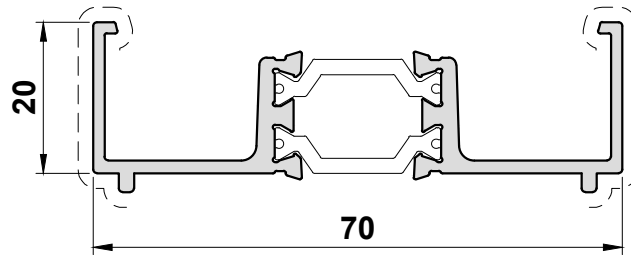
Scale 1:1

Primary Visible Side

Secondary Visible Side

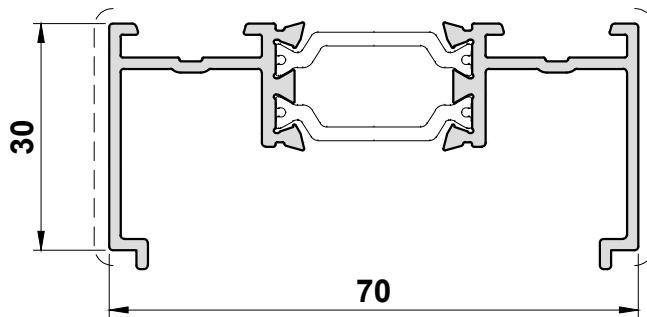
UN3020

70mm x 20mm Frame Extension



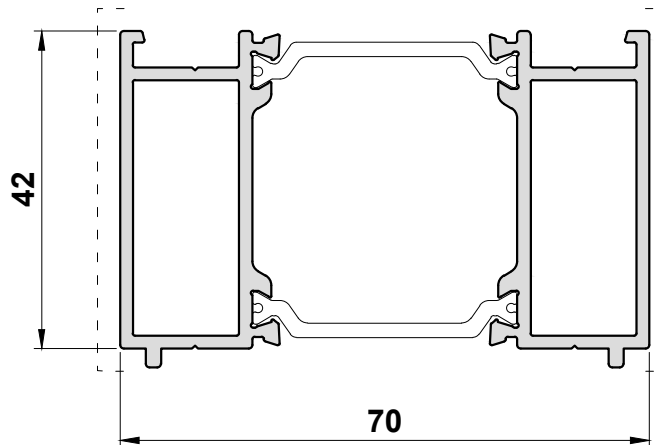
UN3370

30 x 70mm Head Extension



UN3042

42 x 70mm Head Extension

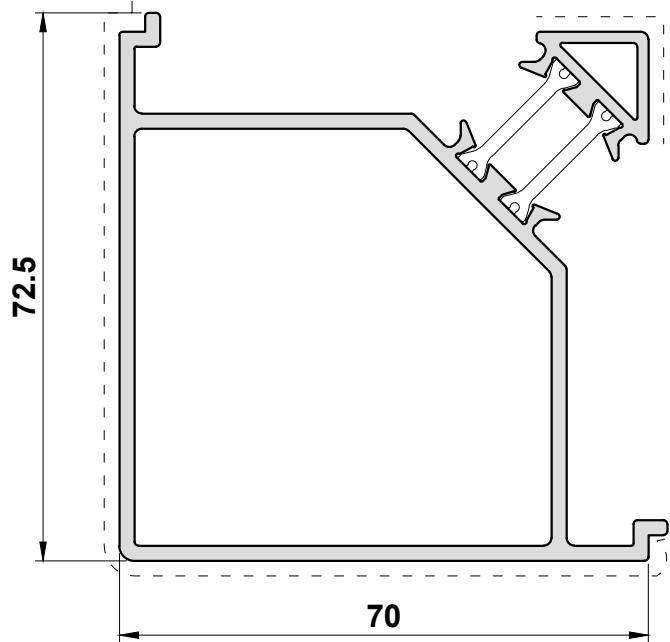


Scale 1:1

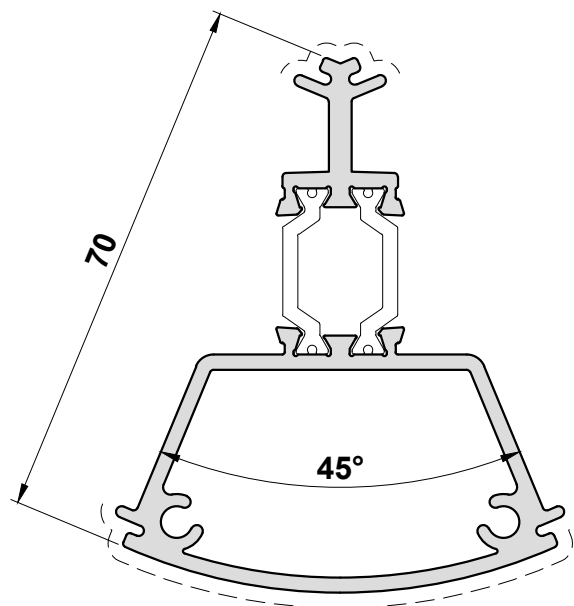
Primary Visible Side

Secondary Visible Side

UN3010
90° Corner Post



UN3011
135° Bay Pole

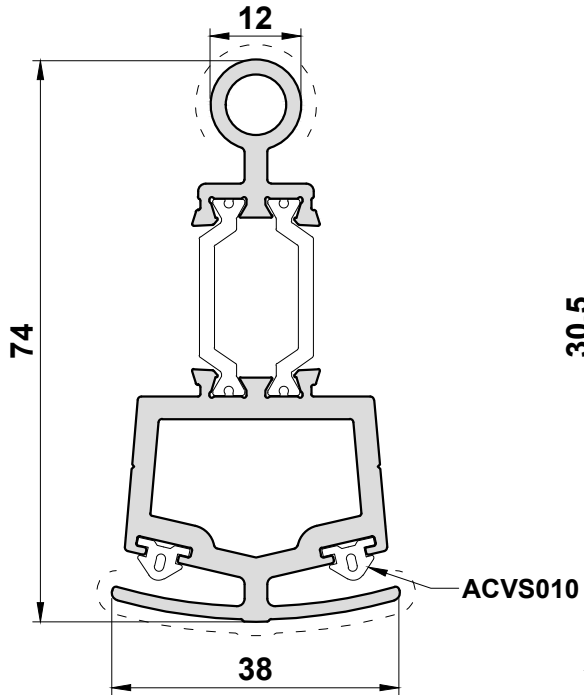


Scale 1:1

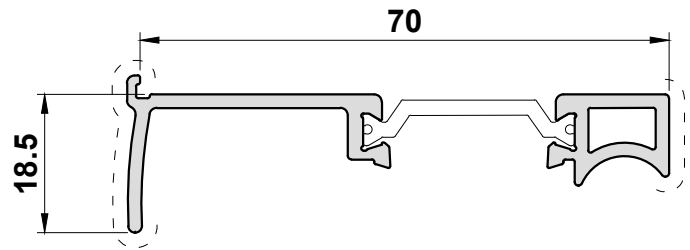
Primary Visible Side

Secondary Visible Side

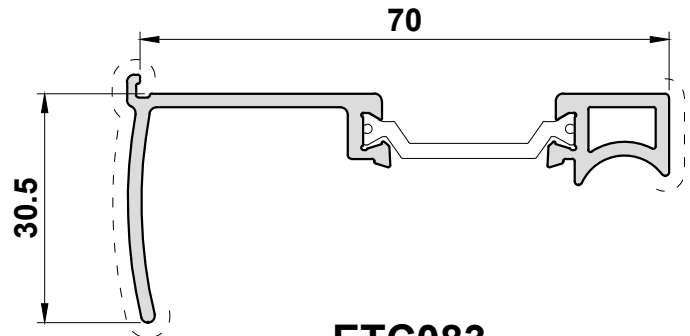
ETC080
Bay Pole



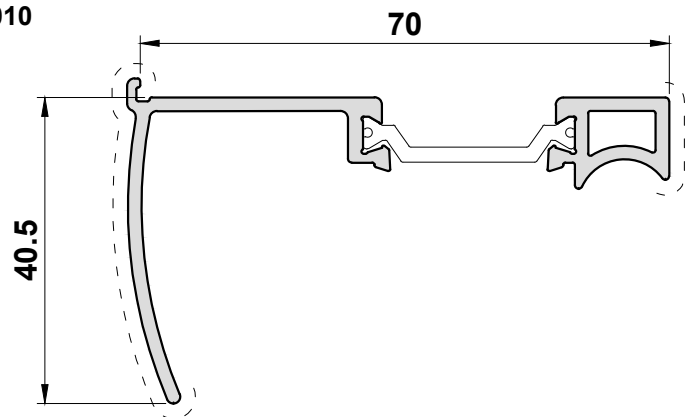
ETC081
169° - 150°
Bay Pole Adaptor



ETC082
149° - 130°
Bay Pole Adaptor



ETC083
129° - 115°
Bay Pole Adaptor

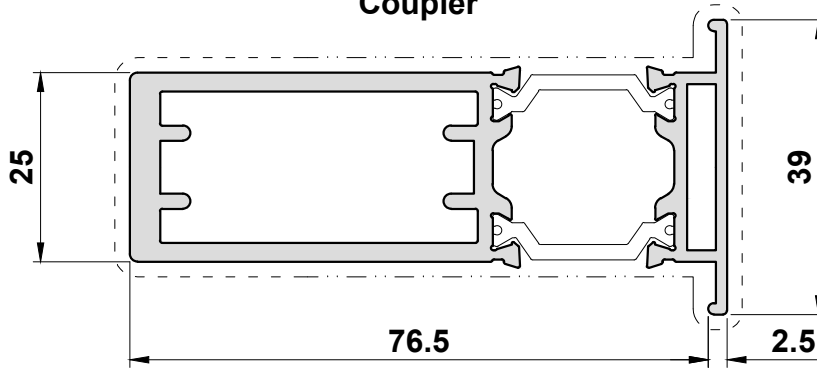


Scale 1:1

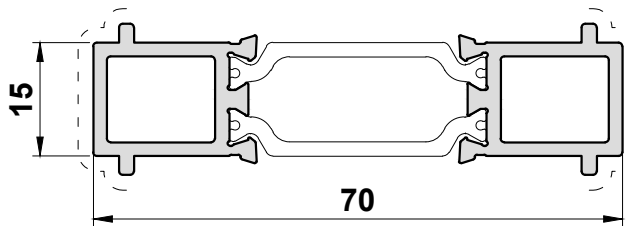
Primary Visible Side

Secondary Visible Side

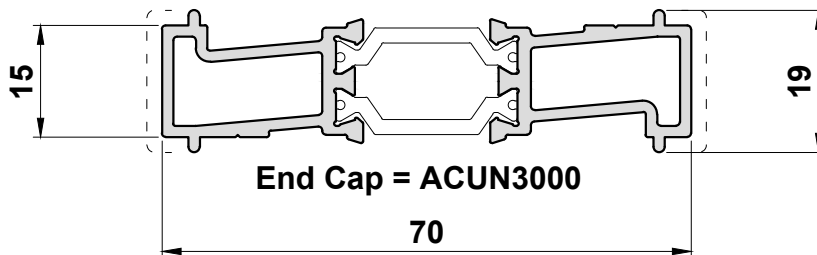
ETC357
Coupler



UN3015
70mm x 15mm Coupler



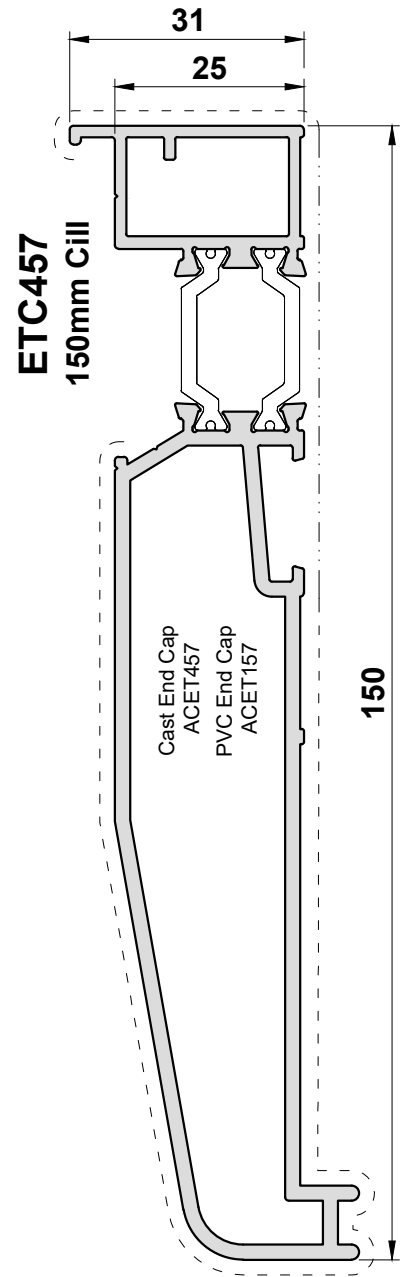
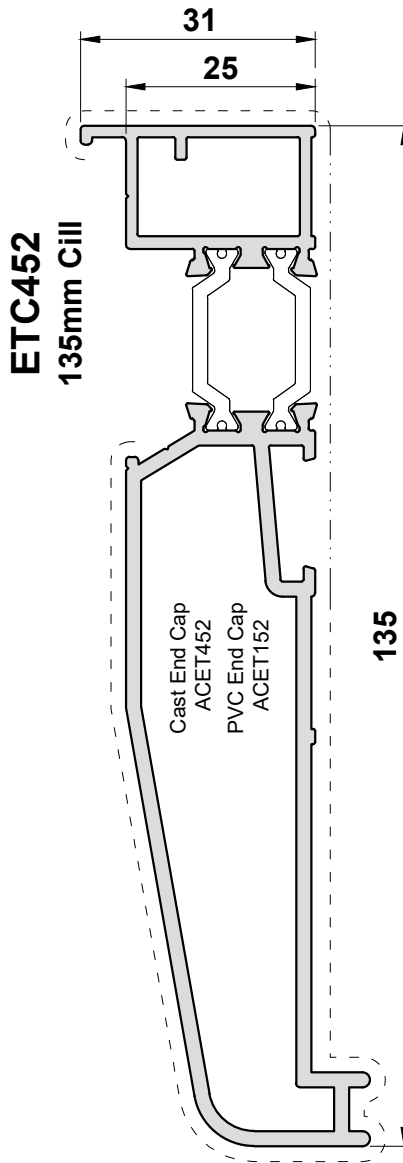
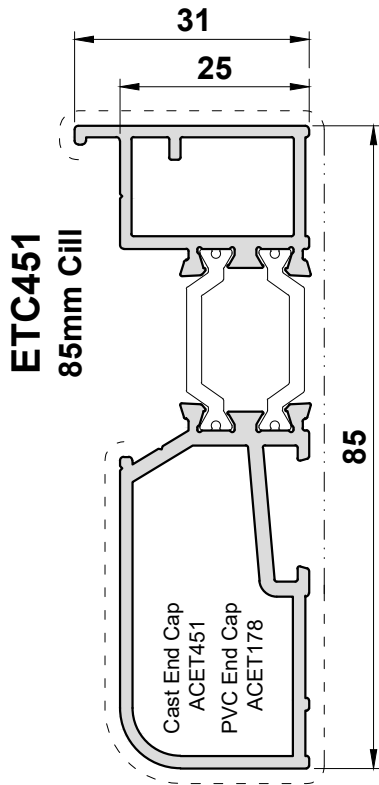
UN3000
Flush Horizontal Coupler



Scale 1:1

Primary Visible Side

Secondary Visible Side

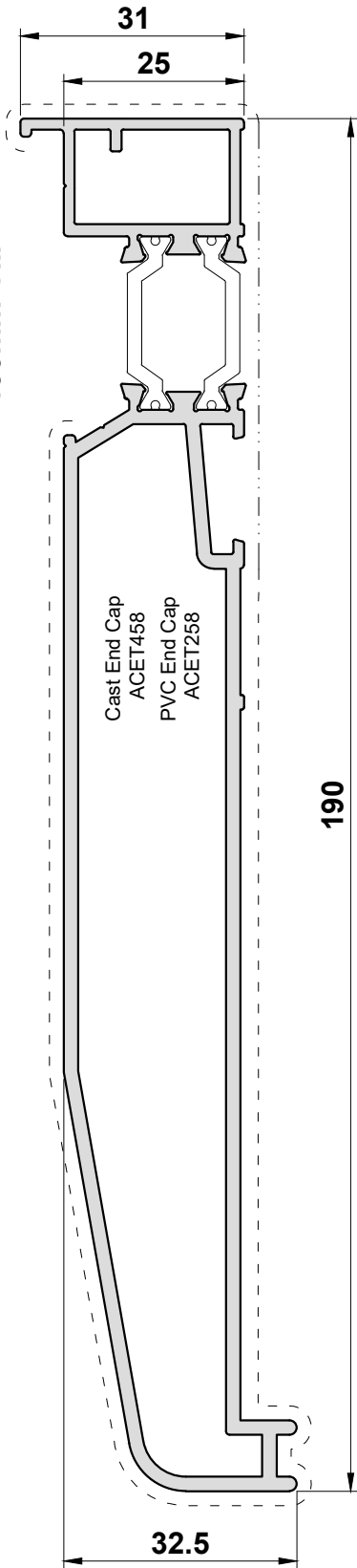


Scale 1:1

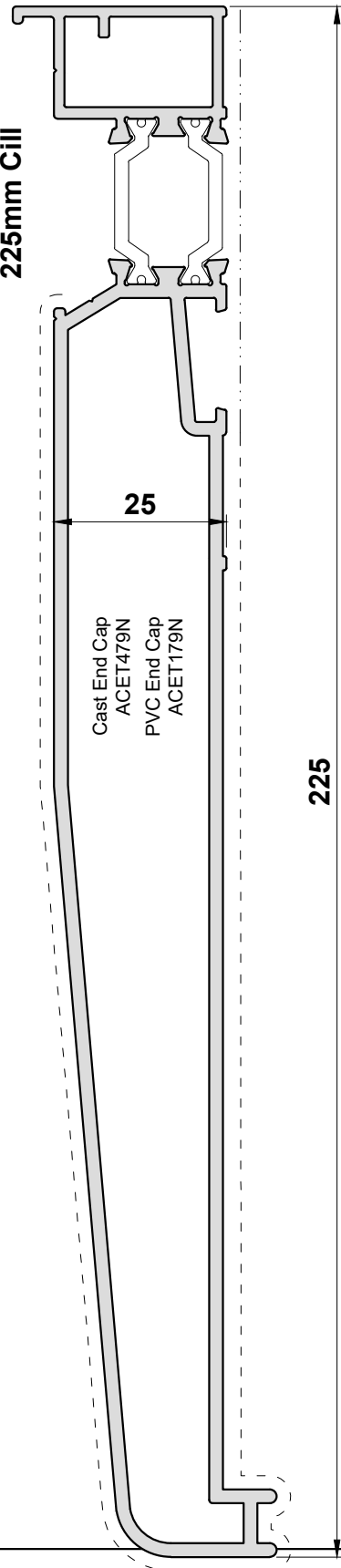
Primary Visible Side

Secondary Visible Side

ETC458
190mm Cill



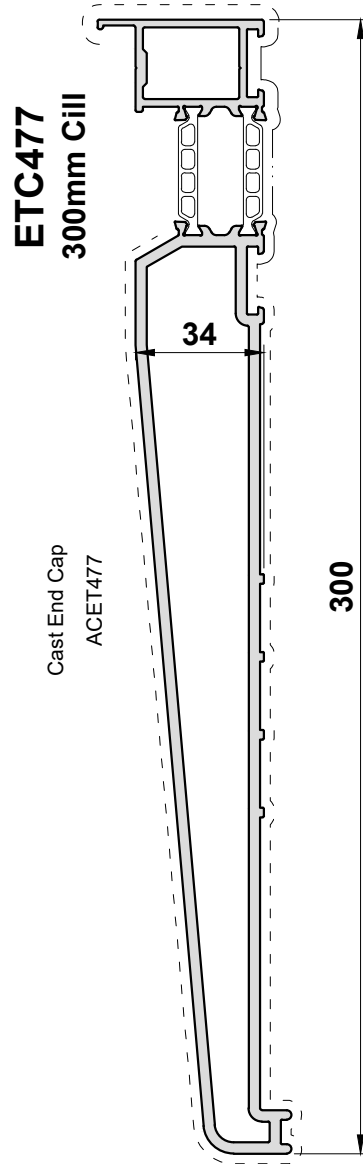
ETC479N
225mm Cill



Scale 1:1

Primary Visible Side

Secondary Visible Side



Scale 1:2

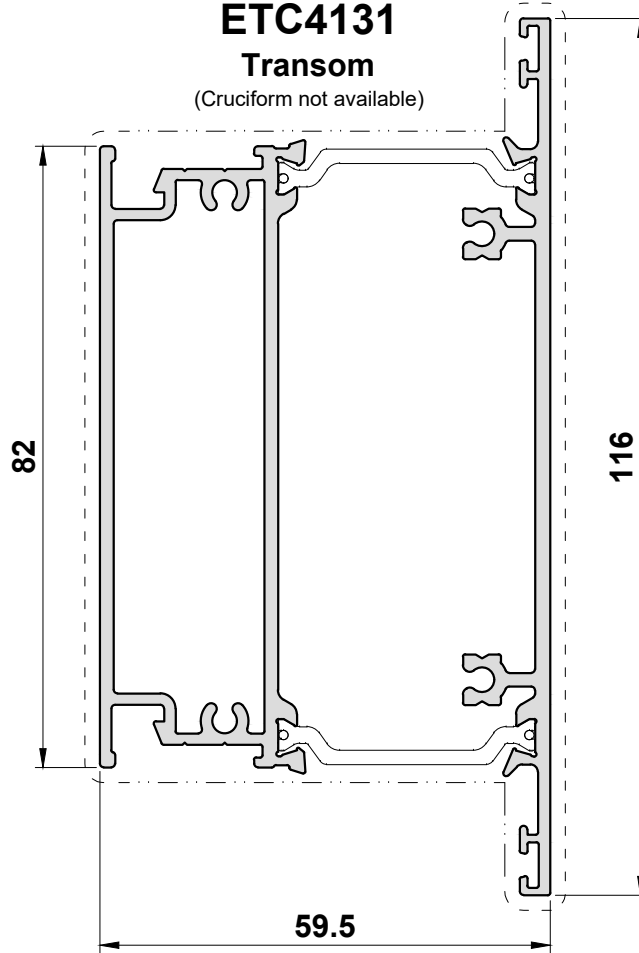
Primary Visible Side

Secondary Visible Side

ETC4131

Transom

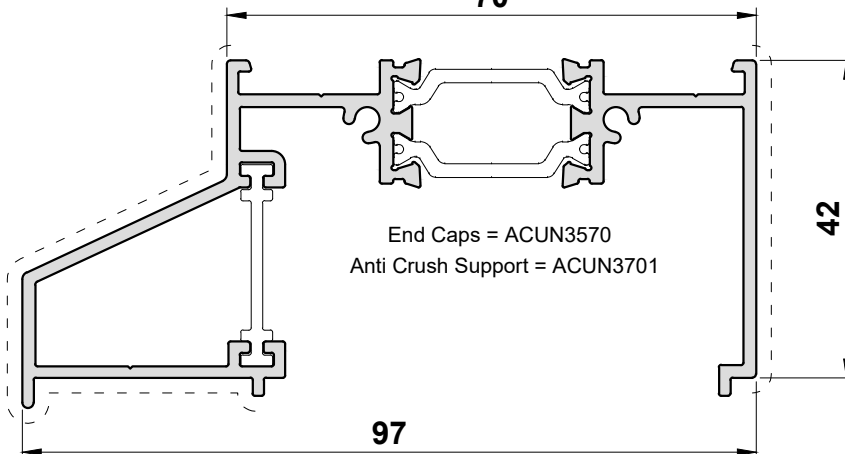
(Cruciform not available)



UN3570

70 x 42mm Hooded Head Extension

70

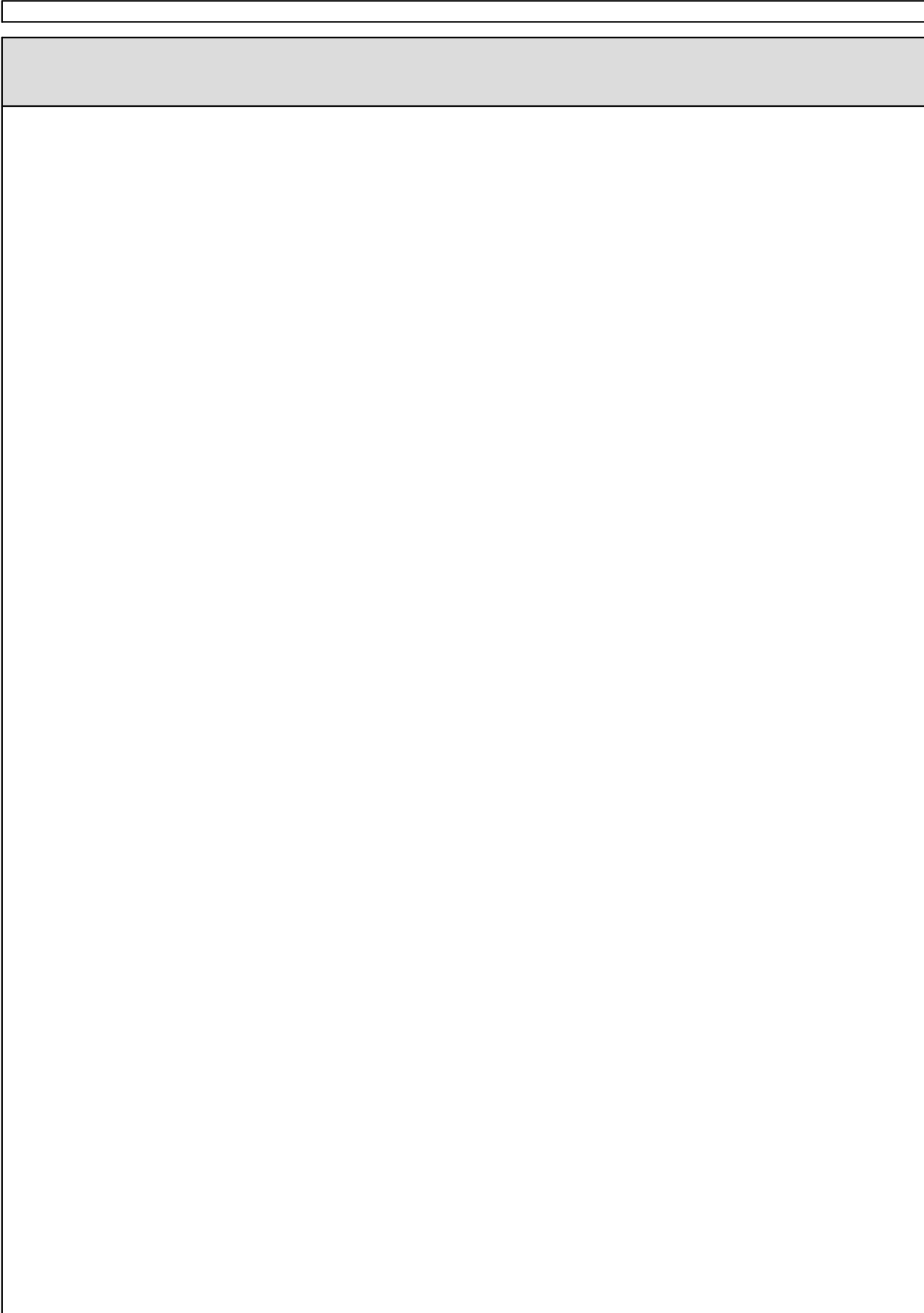


Scale 1:1

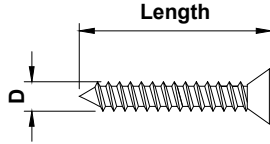
Section B

Accessories

Photos & Drawings



Countersunk Screws



Gauge	'D' (mm)
No.6	3.5
No.7	3.8
No.8	4
No.10	5
No.12	6

Part Number	Gauge	X	Length	Description	Box Qty.
ACUN3530	No.6	X	5/8" (16mm)	Countersunk Pozi Self Tapper S/S	100
MUA025SSZ	No.6	X	1" (25mm)	Countersunk Pozi Self Tapper S/S	100
ACET067	No.7	X	1/2" (12mm)	Countersunk Pozi Self Tapper S/S	100
ACET060	No.7	X	1" (25mm)	Countersunk Pozi Self Tapper S/S	100
ACET066	No.7	X	1 1/2" (40mm)	Countersunk Pozi Self Tapper S/S	100
MUA067SSZ	No.7	X	2" (50mm)	Countersunk Pozi Self Tapper S/S	100
ACET064	No.8	X	5/8" (16mm)	Countersunk Pozi Self Tapper S/S	100
ACUN3512	No.8	X	1 1/4" (30mm)	Countersunk Pozi Self Tapper S/S	100
ACUN3513	No.8	X	1 3/4" (45mm)	Countersunk Pozi Self Tapper S/S	100
ACET072	No.8	X	2 1/2" (60mm)	Countersunk Pozi Self Tapper S/S	100
ACET048	No.10	X	3/8" (10mm)	Countersunk Pozi Self Tapper S/S	100
ACIM062	No.10	X	1 1/4" (30mm)	Countersunk Pozi Self Tapper S/S	100
ACET062	No.10	X	2" (50mm)	Countersunk Pozi Self Tapper S/S	100
ACET076	No.10	X	2 1/2" (60mm)	Countersunk Pozi Self Tapper S/S	100

POLYAMIDE SCREWS

Part Number	Gauge	X	Length	Description	Box Qty.
ACET490	4.3mm	X	16mm	Countersunk PH2 Polyamide Screw	1000
ACET290	4.3mm	X	20mm	Countersunk PH2 Polyamide Screw	100
ACET390	4.3mm	X	25mm	Countersunk PH2 Polyamide Screw	200
ACET190	4.3mm	X	45mm	Countersunk PH2 Polyamide Screw	1000
ACVS062	4.3mm	X	65mm	Countersunk PH2 Polyamide Screw	1000



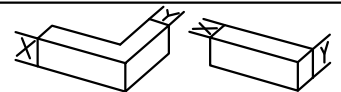
T-BARS
ACVG66=2.5mm
ACVG66=3.0mm
ACVL150=4.0mm



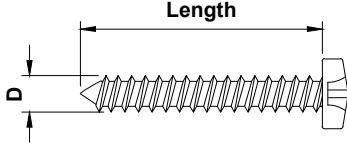
Screw (Grub)

MF = Mill Finish
SA = Silver Anodised
KL = Basic Colour
HP = Special Colour
SSC = Smooth Satin Chrome
SMC = Smokey Chrome
PC = Polished Chrome

W = White
Z = Black



Pan Head Screws



Gauge	'D' (mm)
No.6	3.5
No.7	3.8
No.8	4
No.10	5
No.12	6

Part Number	Gauge	X	Length	Description	Box Qty.
ACET068	No.8	X	3/8" (10mm)	Pozi Flange AB	100
ACET063	No.8	X	1/2" (12mm)	Pan Head Self Tapper	100
ACET070	No.8	X	1/2" (12mm)	Pozi Flange Self Tapper S/S	100
ACUN3535	No.8	X	5/8" (16mm)	Pan Head Pozi S/S	100
ACET099	No.8	X	3/4" (20mm)	Pozi Flange Self Tapper S/S	100
ACDR050	4.8mm	X	32mm	Pan Head Pozi S/S	200
PUA028	No.10	X	1" (25mm)	Pan Head Pozi S/S	100
ACDR052	No.10	X	2" (50mm)	Pan Head Self Tapper S/S	200
ACET079	No.10	X	2 1/2" (60mm)	Pan Head Pozi S/S	100
ACW20160	No.12	X	1" (25mm)	Flange Head Self Tapper S/S	100
ACMC109	6.3mm	X	38mm	DIN7981 - Pan Head Self Tapper	200



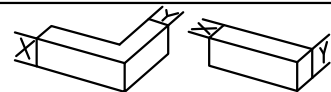
T-BARS
ACVG65=2.5mm
ACVG66=3.0mm
ACVL150=4.0mm



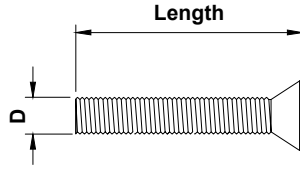
Screw (Grub)

MF = Mill Finish
SA = Silver Anodised
KL = Basic Colour
HP = Special Colour
SSC = Smooth Satin Chrome
SMC = Smokey Chrome
PC = Polished Chrome

W = White
Z = Black



Machine Screws



Thread	'D' (mm) Nominal
M4	4
M5	5
M6	6
M8	8
M10	10

Part Number	Thread	X	Length	Description	Box Qty.
ACET122	M4	X	10	CSK Pozi Machine Screw	100
ACET123	M4	X	20	CSK Pozi Machine Screw	100
ACDV264	M4	X	35	CSK Pozi Machine Screw	100
ACSG071	M4	X	40	CSK Pozi Machine Screw	100
ACDV266	M4	X	45	CSK Pozi Machine Screw	100
ACDV262	M4	X	50	CSK Pozi Machine Screw	100
ACDV265	M4	X	60	CSK Pozi Machine Screw	100
ACDR051	M5	X	10	CSK Pozi Machine Screw	100
ACET069	M5	X	12	CSK Pozi Machine Screw	100
HEA132	M5	X	16	CSK Pozi Machine Screw	100
WCA134	M5	X	20	CSK Pozi Machine Screw	100
WCA143	M5	X	25	CSK Pozi Machine Screw	50
ACVS061	M5	X	40	CSK Pozi Machine Screw	100
ACET133	M5	X	50	CSK Pozi Machine Screw	100
ACET220	M5	X	60	CSK Pozi Machine Screw	100
ACET238	M5	X	70	CSK Pozi Machine Screw	100
ACMX861	M5	X	80	DIN965 - CSK Machine Screw	10
ACMX862	M5	X	90	DIN965 - CSK Machine Screw	10
ACUN3503	M6	X	10	CSK Socket Machine Screw	24
ACUN3501	M6	X	13	CSK Flange Socket Machine Screw	48
ACMX852	M6	X	16	DIN965 - CSK Machine Screw	10
HEA390	M6	X	16	CSK Socket Machine Screw	32
ACET235	M6	X	60	CSK Pozi Machine Screw	100
ACET237	M6	X	70	CSK Pozi Machine Screw	100



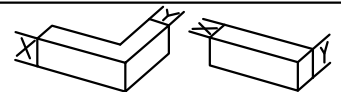
T-BARS
ACVG66=2.5mm
ACVG66=3.0mm
ACVL150=4.0mm



Screw (Grub)

MF = Mill Finish
SA = Silver Anodised
KL = Basic Colour
HP = Special Colour
SSC = Smooth Satin Chrome
SMC = Smokey Chrome
PC = Polished Chrome








W = White
Z = Black



Glazing Gaskets

Retaining Gasket












Commonly known as an E Gasket.
Retaining gaskets create a seal between the Glass and the Aluminium Profile.

High Line	Thickness		Part number		
			Coil length	Available Colours	
High Line	2mm		ACVG231	200m	BL
			ACVG31	200m	BL
			ACVG131	100m	BL
Low Line	2mm		ACET843	200m	BL
			ACET842	200m	BL
			ACET841	200m	BL
	3mm		ACET835	200m	BL
			ACVG131N	100m	BL
	4mm		ACUN3065	100m	BL
			ACVG131N	100m	BL
	4mm		ACVG131N	100m	BL
			ACUN3065	100m	BL
	5mm		ACVG131N	100m	BL
ACUN3065			100m	BL	

Thickness	Drawing 1:1	Part number	
		Coil length	Available Colours

Wedge Gasket

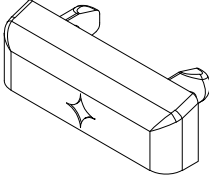
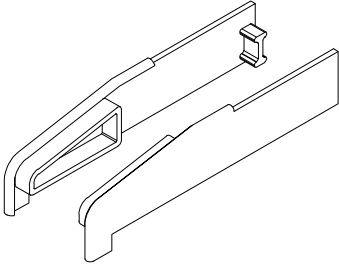
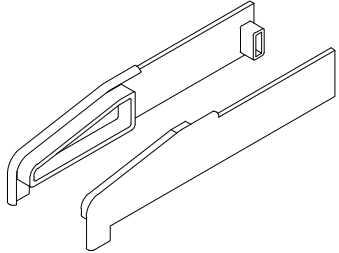
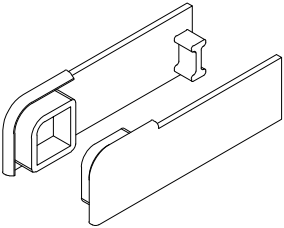
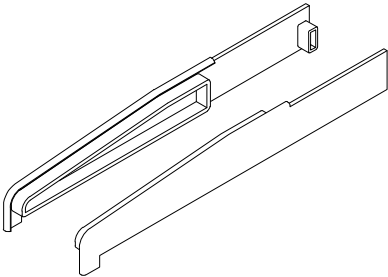



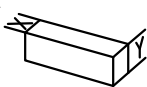
Wedge Gaskets help to hold the bead in place by providing tension between the bead and the glazing unit.

High Line	Thickness		Part number		
			Coil length	Available Colours	
High Line	3mm		ACVG32	100m	BL
			ACVG32N	100m	BL
			ACVG33	100m	BL
	3mm		ACVG33N	100m	BL
			ACVG34	100m	BL
	4mm		ACVG34N	100m	BL
			ACVG340	100m	BL
	4mm		ACVG340N	100m	BL
			ACVG340	100m	BL
	5mm		ACVG340N	100m	BL
			ACVG340	100m	BL
	5mm		ACVG340N	100m	BL
			ACVG340	100m	BL
	6mm		ACVG340N	100m	BL
			ACVG340	100m	BL
6mm		ACVG340N	100m	BL	
		ACVG340	100m	BL	
Low Line	4mm - 3mm		ACW20038	50m	BL
			ACW20038	50m	BL
			ACW20038	50m	BL
5mm - 4mm		ACET848	200m	BL	
		ACET848	200m	BL	

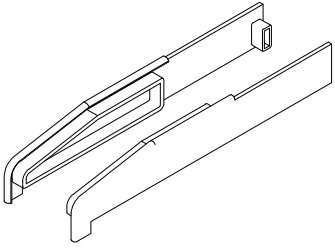
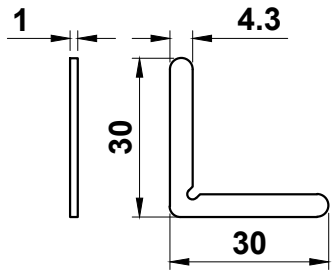
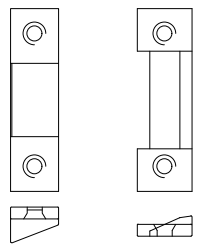
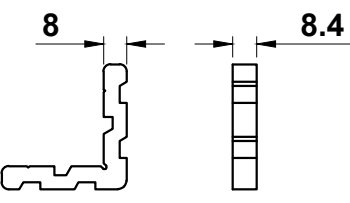
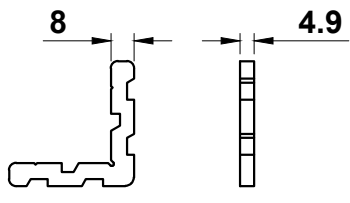


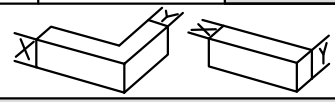
ACCESSORIES : PHOTOS & DRAWINGS

Image	Part Code	Pack	Unit	Application	Colour	
	ACDV620 Mechanical Cleat	24	Pack	ETC4129	MF	✓
					SA	
					KL	
					HP	
					SSC	
					SMC	
					W	
					Z	
					PC	
	ACDV916 Bead Punch Tool	1	each	UN3160G UN3160	MF	
					SA	
					KL	
					HP	
					SSC	
					SMC	
					W	
					Z	
					PC	
	ACET041 Cill Nose Bracket	1	Each	ETC451 ETC452 ETC457 ETC458 ETC477 ETC479	MF	✓
					SA	
					KL	
					HP	
					SSC	
					SMC	
					W	
					Z	
					PC	
	ACET125 Anti-Twist Clip	100	Pack	ETC4110 ETC4112 ETC4130	MF	✓
					SA	
					KL	
					HP	
					SSC	
					SMC	
					W	
					Z	
					PC	
	ACET130 Galvanised Steel Fixing Strap 200mm x 25mm x 1.5mm	100	Pack	ETC4110 ETC4111 ETC4112 ETC4115	MF	
					SA	
					KL	
					HP	
					SSC	
					SMC	
					W	
					Z	
					PC	
 <small>T-BARS ACVG65=2.5mm ACVG66=3.0mm ACVL150=4.0mm</small>	 <small>Screw (Grub)</small>	MF = Mill Finish SA = Silver Anodised KL = Basic Colour HP = Special Colour SSC = Smooth Satin Chrome SMC = Smokey Chrome PC = Polished Chrome	W = White Z = Black	 		

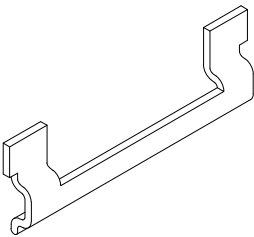
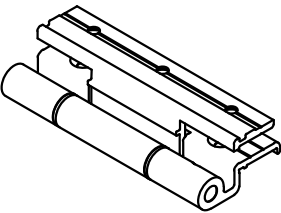
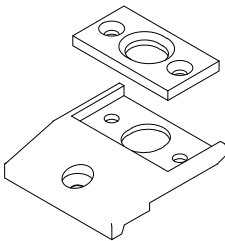
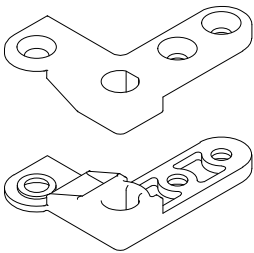
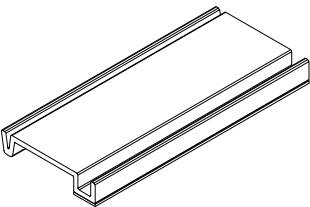


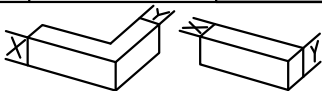
ACCESSORIES : PHOTOS & DRAWINGS

Image	Part Code	Pack	Unit	Application	Colour
	ACET131 Drainage Cover Cap For colour matched drainage caps, please order ACET432	100	Pack	ETC4110 ETC4111 ETC4112 ETC4115 ETC4130 ETC4135 UN3000	MF
					SA
	ACET152 Cill End Cap	10	Pair	ACET452	KL
					HP
	ACET157 Cill End Cap	10	Pair	ETC457	SSC
					SMC
	ACET178 Cill End Cap	10	Pair	ETC451	W
					Z
	ACET179N Cill End Cap	10	Pair	ETC479N	PC
 T-BARS ACVG65=2.5mm ACVG66=3.0mm ACVL150=4.0mm	 Screw (Grub)	MF = Mill Finish SA = Silver Anodised KL = Basic Colour HP = Special Colour SSC = Smooth Satin Chrome SMC = Smokey Chrome PC = Polished Chrome	W = White Z = Black	 	



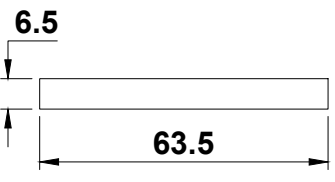
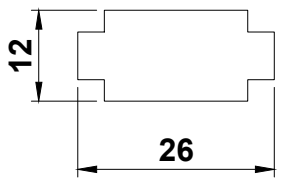
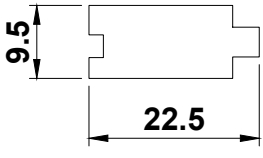


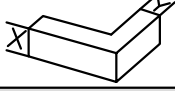
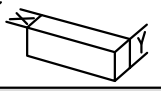
ACCESSORIES : PHOTOS & DRAWINGS

Image	Part Code	Pack	Unit	Application	Colour	
	ACET258 Cill End Cap	10	Pair	ETC458	MF	
					SA	
					KL	
					HP	
					SSC	
					SMC	
					W	✓
					Z	✓
PC						
	ACET311 Stainless Steel Chevron	50	Pack	ETC4110 ETC4111 ETC4112 ETC4113 ETC4115 ETC4117 ETC4120 ETC4124 ETC4146 ETC4147	MF	
					SA	
					KL	
					HP	
					SSC	
					SMC	
					W	
					Z	
					PC	
	ACET352 Pull in Block for Egress Hinges 2 x ACET394 required	50	pack	ETC4124	MF	
					SA	
					KL	
					HP	
					SSC	
					SMC	
					W	
					Z	
PC						
	ACET4026 Crimping Cleat	1	Each	ETC4124	MF	✓
					SA	
					KL	
					HP	
					SSC	
					SMC	
					W	
					Z	
PC						
	ACET4027 Crimping Cleat	1	Each	ETC4124	MF	✓
					SA	
					KL	
					HP	
					SSC	
					SMC	
					W	
					Z	
PC						
 T-BARS ACVG66=2.5mm ACVG66=3.0mm ACVL150=4.0mm	 Screw (Grub)	MF = Mill Finish SA = Silver Anodised KL = Basic Colour HP = Special Colour SSC = Smooth Satin Chrome SMC = Smokey Chrome PC = Polished Chrome	W = White Z = Black			

ACCESSORIES : PHOTOS & DRAWINGS

Image	Part Code	Pack	Unit	Application	Colour																		
	ACET4036 Anti-Twist Clip	100	Pack	ETC4115 ETC4135	<table border="1"> <tr><td>MF</td><td>✓</td></tr> <tr><td>SA</td><td></td></tr> <tr><td>KL</td><td></td></tr> <tr><td>HP</td><td></td></tr> <tr><td>SSC</td><td></td></tr> <tr><td>SMC</td><td></td></tr> <tr><td>W</td><td></td></tr> <tr><td>Z</td><td></td></tr> <tr><td>PC</td><td></td></tr> </table>	MF	✓	SA		KL		HP		SSC		SMC		W		Z		PC	
MF	✓																						
SA																							
KL																							
HP																							
SSC																							
SMC																							
W																							
Z																							
PC																							
	ACET4050 Butt Hinge	1	Each	ETC4110 ETC4111 ETC4112 ETC4113 ETC4120 ETC4129	<table border="1"> <tr><td>MF</td><td></td></tr> <tr><td>SA</td><td></td></tr> <tr><td>KL</td><td></td></tr> <tr><td>HP</td><td></td></tr> <tr><td>SSC</td><td></td></tr> <tr><td>SMC</td><td></td></tr> <tr><td>W</td><td></td></tr> <tr><td>Z</td><td></td></tr> <tr><td>PC</td><td></td></tr> </table>	MF		SA		KL		HP		SSC		SMC		W		Z		PC	
MF																							
SA																							
KL																							
HP																							
SSC																							
SMC																							
W																							
Z																							
PC																							
	ACET4054 French Casement Keep Kit Kit Contains: 2 x Packers 2 x Reversible Keeps	1	Pack	ETC4138 ACET4055 ACET4138 ACUN3055	<table border="1"> <tr><td>MF</td><td></td></tr> <tr><td>SA</td><td></td></tr> <tr><td>KL</td><td></td></tr> <tr><td>HP</td><td></td></tr> <tr><td>SSC</td><td></td></tr> <tr><td>SMC</td><td></td></tr> <tr><td>W</td><td></td></tr> <tr><td>Z</td><td></td></tr> <tr><td>PC</td><td></td></tr> </table>	MF		SA		KL		HP		SSC		SMC		W		Z		PC	
MF																							
SA																							
KL																							
HP																							
SSC																							
SMC																							
W																							
Z																							
PC																							
	ACET4055 French Casement Shootbolt Guide	1	Pair	ETC4138 ACET4054 ACET4138 ACUN3055	<table border="1"> <tr><td>MF</td><td></td></tr> <tr><td>SA</td><td></td></tr> <tr><td>KL</td><td></td></tr> <tr><td>HP</td><td></td></tr> <tr><td>SSC</td><td></td></tr> <tr><td>SMC</td><td></td></tr> <tr><td>W</td><td></td></tr> <tr><td>Z</td><td>✓</td></tr> <tr><td>PC</td><td></td></tr> </table>	MF		SA		KL		HP		SSC		SMC		W		Z	✓	PC	
MF																							
SA																							
KL																							
HP																							
SSC																							
SMC																							
W																							
Z	✓																						
PC																							
	ACET4058 Bridge Packer	12	Pack	ETC4129	<table border="1"> <tr><td>MF</td><td></td></tr> <tr><td>SA</td><td></td></tr> <tr><td>KL</td><td></td></tr> <tr><td>HP</td><td></td></tr> <tr><td>SSC</td><td></td></tr> <tr><td>SMC</td><td></td></tr> <tr><td>W</td><td></td></tr> <tr><td>Z</td><td></td></tr> <tr><td>PC</td><td></td></tr> </table>	MF		SA		KL		HP		SSC		SMC		W		Z		PC	
MF																							
SA																							
KL																							
HP																							
SSC																							
SMC																							
W																							
Z																							
PC																							
 <p>T-BARS ACVG65=2.5mm ACVG66=3.0mm ACVL150=4.0mm</p>  <p>Screw (Grub)</p>	<p>MF = Mill Finish SA = Silver Anodised KL = Basic Colour HP = Special Colour SSC = Smooth Satin Chrome SMC = Smokey Chrome PC = Polished Chrome</p> <p>W = White Z = Black</p>																						

ACCESSORIES : PHOTOS & DRAWINGS

Image	Part Code	Pack	Unit	Application	Colour
	ACET4067 Non-Locking Espagnolette Handle Silver Anodised	1	Pack	ACET4001 to AET4006	MF
					SA
					KL
					HP
					SSC
					SMC
					W
					Z
					PC
	ACET4068 Locking Espagnolette Handle Silver Anodised	1	Pack	ACET4001 to AET4006	MF
					SA
					KL
					HP
					SSC
					SMC
					W
					Z
					PC
	ACET4070 Foam	1	Each	ETC4110 ETC4111 ETC4112 ETC4113 ETC4115	MF
					SA
					KL
					HP
					SSC
					SMC
					W
					Z
					PC
	ACET4071 Foam	1	Each	ETC4110 ETC4111 ETC4112 ETC4113 ETC4115	MF
					SA
					KL
					HP
					SSC
					SMC
					W
					Z
					PC
	ACET4072 Foam	1	Each	ETC4120	MF
					SA
					KL
					HP
					SSC
					SMC
					W
					Z
					PC
 T-BARS ACVG66=2.5mm ACVG66=3.0mm ACVL150=4.0mm	 Screw (Grub)	MF = Mill Finish SA = Silver Anodised KL = Basic Colour HP = Special Colour SSC = Smooth Satin Chrome SMC = Smokey Chrome PC = Polished Chrome	W = White Z = Black	 	

ACCESSORIES : PHOTOS & DRAWINGS

Image	Part Code	Pack	Unit	Application	Colour	
	ACET4073 Foam	1	Each	ETC4129	MF	
					SA	
					KL	
					HP	
					SSC	
					SMC	
					W	
					Z	✓
					PC	
						ACET4075 Foam
SA						
KL						
HP						
SSC						
SMC						
W						
Z	✓					
PC						
	ACET4076 Foam	1	Each	ETC4135		
					SA	
					KL	
					HP	
					SSC	
					SMC	
					W	
					Z	✓
					PC	
						ACET4077 Foam
SA						
KL						
HP						
SSC						
SMC						
W						
Z	✓					
PC						
	ACET4078 Foam	1	Each	ETC4147		
					SA	
					KL	
					HP	
					SSC	
					SMC	
					W	
					Z	✓
					PC	
						MF = Mill Finish SA = Silver Anodised KL = Basic Colour HP = Special Colour SSC = Smooth Satin Chrome SMC = Smokey Chrome PC = Polished Chrome

ACCESSORIES : PHOTOS & DRAWINGS

Image	Part Code	Pack	Unit	Application	Colour																		
	ACET4081 Foam	1	Each	ETC4129	<table border="1"> <tr><td>MF</td><td></td></tr> <tr><td>SA</td><td></td></tr> <tr><td>KL</td><td></td></tr> <tr><td>HP</td><td></td></tr> <tr><td>SSC</td><td></td></tr> <tr><td>SMC</td><td></td></tr> <tr><td>W</td><td></td></tr> <tr><td>Z</td><td>✓</td></tr> <tr><td>PC</td><td></td></tr> </table>	MF		SA		KL		HP		SSC		SMC		W		Z	✓	PC	
MF																							
SA																							
KL																							
HP																							
SSC																							
SMC																							
W																							
Z	✓																						
PC																							
	ACET4082 Foam	1	Each	ETC4110 ETC4111 ETC4112 ETC4113 ETC4115 ETC4120 ETC4130 ETC4135	<table border="1"> <tr><td>MF</td><td></td></tr> <tr><td>SA</td><td></td></tr> <tr><td>KL</td><td></td></tr> <tr><td>HP</td><td></td></tr> <tr><td>SSC</td><td></td></tr> <tr><td>SMC</td><td></td></tr> <tr><td>W</td><td></td></tr> <tr><td>Z</td><td>✓</td></tr> <tr><td>PC</td><td></td></tr> </table>	MF		SA		KL		HP		SSC		SMC		W		Z	✓	PC	
MF																							
SA																							
KL																							
HP																							
SSC																							
SMC																							
W																							
Z	✓																						
PC																							
	ACET4110 Crimping Cleat	24	Pack	ETC4110 ETC4111 ETC4112 ETC4113 ETC4115	<table border="1"> <tr><td>MF</td><td>✓</td></tr> <tr><td>SA</td><td></td></tr> <tr><td>KL</td><td></td></tr> <tr><td>HP</td><td></td></tr> <tr><td>SSC</td><td></td></tr> <tr><td>SMC</td><td></td></tr> <tr><td>W</td><td></td></tr> <tr><td>Z</td><td></td></tr> <tr><td>PC</td><td></td></tr> </table>	MF	✓	SA		KL		HP		SSC		SMC		W		Z		PC	
MF	✓																						
SA																							
KL																							
HP																							
SSC																							
SMC																							
W																							
Z																							
PC																							
	ACET4111 Mechanical Cleat	24	Pack	ETC4110 ETC4111 ETC4112 ETC4129	<table border="1"> <tr><td>MF</td><td>✓</td></tr> <tr><td>SA</td><td></td></tr> <tr><td>KL</td><td></td></tr> <tr><td>HP</td><td></td></tr> <tr><td>SSC</td><td></td></tr> <tr><td>SMC</td><td></td></tr> <tr><td>W</td><td></td></tr> <tr><td>Z</td><td></td></tr> <tr><td>PC</td><td></td></tr> </table>	MF	✓	SA		KL		HP		SSC		SMC		W		Z		PC	
MF	✓																						
SA																							
KL																							
HP																							
SSC																							
SMC																							
W																							
Z																							
PC																							
	ACET4115 Crimping Cleat	24	Pack	ETC4115	<table border="1"> <tr><td>MF</td><td>✓</td></tr> <tr><td>SA</td><td></td></tr> <tr><td>KL</td><td></td></tr> <tr><td>HP</td><td></td></tr> <tr><td>SSC</td><td></td></tr> <tr><td>SMC</td><td></td></tr> <tr><td>W</td><td></td></tr> <tr><td>Z</td><td></td></tr> <tr><td>PC</td><td></td></tr> </table>	MF	✓	SA		KL		HP		SSC		SMC		W		Z		PC	
MF	✓																						
SA																							
KL																							
HP																							
SSC																							
SMC																							
W																							
Z																							
PC																							
<p>T-BARS ACVG66=2.5mm ACVG66=3.0mm ACVL150=4.0mm</p> <p>Screw (Grub)</p>	MF = Mill Finish SA = Silver Anodised KL = Basic Colour HP = Special Colour SSC = Smooth Satin Chrome SMC = Smokey Chrome PC = Polished Chrome	W = White Z = Black																					

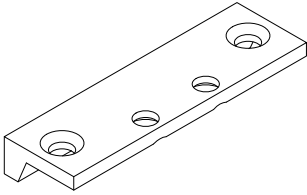
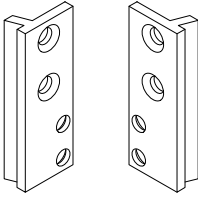
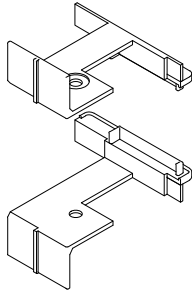
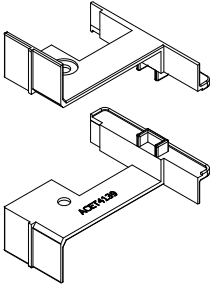
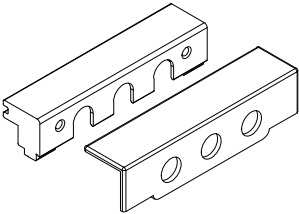


ACCESSORIES : PHOTOS & DRAWINGS

Image	Part Code	Pack	Unit	Application	Colour																		
	ACET4120 Crimping Cleat	24	Pack	ETC4120	<table border="1"> <tr><td>MF</td><td>✓</td></tr> <tr><td>SA</td><td></td></tr> <tr><td>KL</td><td></td></tr> <tr><td>HP</td><td></td></tr> <tr><td>SSC</td><td></td></tr> <tr><td>SMC</td><td></td></tr> <tr><td>W</td><td></td></tr> <tr><td>Z</td><td></td></tr> <tr><td>PC</td><td></td></tr> </table>	MF	✓	SA		KL		HP		SSC		SMC		W		Z		PC	
MF	✓																						
SA																							
KL																							
HP																							
SSC																							
SMC																							
W																							
Z																							
PC																							
	ACET4122 Crimping Cleat	24	Pack	ETC4146	<table border="1"> <tr><td>MF</td><td>✓</td></tr> <tr><td>SA</td><td></td></tr> <tr><td>KL</td><td></td></tr> <tr><td>HP</td><td></td></tr> <tr><td>SSC</td><td></td></tr> <tr><td>SMC</td><td></td></tr> <tr><td>W</td><td></td></tr> <tr><td>Z</td><td></td></tr> <tr><td>PC</td><td></td></tr> </table>	MF	✓	SA		KL		HP		SSC		SMC		W		Z		PC	
MF	✓																						
SA																							
KL																							
HP																							
SSC																							
SMC																							
W																							
Z																							
PC																							
	ACET4123 Mechanical Cleat	24	Pack	ETC4146	<table border="1"> <tr><td>MF</td><td>✓</td></tr> <tr><td>SA</td><td></td></tr> <tr><td>KL</td><td></td></tr> <tr><td>HP</td><td></td></tr> <tr><td>SSC</td><td></td></tr> <tr><td>SMC</td><td></td></tr> <tr><td>W</td><td></td></tr> <tr><td>Z</td><td></td></tr> <tr><td>PC</td><td></td></tr> </table>	MF	✓	SA		KL		HP		SSC		SMC		W		Z		PC	
MF	✓																						
SA																							
KL																							
HP																							
SSC																							
SMC																							
W																							
Z																							
PC																							
	ACET4124 Crimping Cleat	24	Pack	ETC4147	<table border="1"> <tr><td>MF</td><td>✓</td></tr> <tr><td>SA</td><td></td></tr> <tr><td>KL</td><td></td></tr> <tr><td>HP</td><td></td></tr> <tr><td>SSC</td><td></td></tr> <tr><td>SMC</td><td></td></tr> <tr><td>W</td><td></td></tr> <tr><td>Z</td><td></td></tr> <tr><td>PC</td><td></td></tr> </table>	MF	✓	SA		KL		HP		SSC		SMC		W		Z		PC	
MF	✓																						
SA																							
KL																							
HP																							
SSC																							
SMC																							
W																							
Z																							
PC																							
	ACET4125 Mechanical Cleat	24	Pack	ETC4146	<table border="1"> <tr><td>MF</td><td>✓</td></tr> <tr><td>SA</td><td></td></tr> <tr><td>KL</td><td></td></tr> <tr><td>HP</td><td></td></tr> <tr><td>SSC</td><td></td></tr> <tr><td>SMC</td><td></td></tr> <tr><td>W</td><td></td></tr> <tr><td>Z</td><td></td></tr> <tr><td>PC</td><td></td></tr> </table>	MF	✓	SA		KL		HP		SSC		SMC		W		Z		PC	
MF	✓																						
SA																							
KL																							
HP																							
SSC																							
SMC																							
W																							
Z																							
PC																							
	MF = Mill Finish SA = Silver Anodised KL = Basic Colour HP = Special Colour SSC = Smooth Satin Chrome SMC = Smokey Chrome PC = Polished Chrome	W = White Z = Black																					

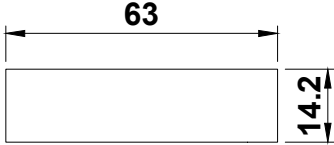
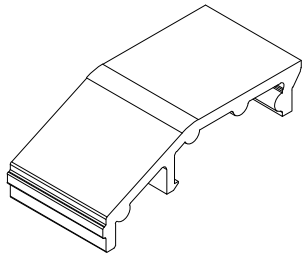
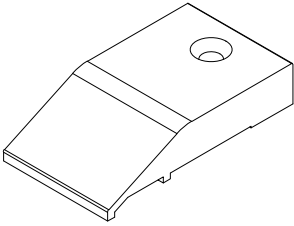
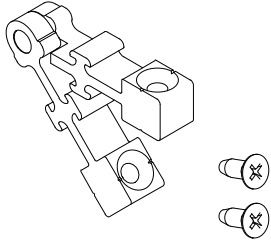
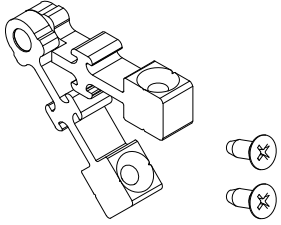

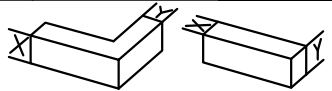
ACCESSORIES : PHOTOS & DRAWINGS

Image	Part Code	Pack	Unit	Application	Colour
	ACET4127 Crimping Cleat	24	Pack	ETC4147	MF <input checked="" type="checkbox"/>
					SA <input type="checkbox"/>
					KL <input type="checkbox"/>
					HP <input type="checkbox"/>
					SSC <input type="checkbox"/>
					SMC <input type="checkbox"/>
					W <input type="checkbox"/>
					Z <input type="checkbox"/>
					PC <input type="checkbox"/>
					PC <input type="checkbox"/>
	ACET4128 Adhesive Packer	12	Pack	ETC4147	MF <input checked="" type="checkbox"/>
					SA <input type="checkbox"/>
					KL <input type="checkbox"/>
					HP <input type="checkbox"/>
					SSC <input type="checkbox"/>
					SMC <input type="checkbox"/>
					W <input type="checkbox"/>
					Z <input type="checkbox"/>
					PC <input type="checkbox"/>
					PC <input type="checkbox"/>
	ACET4129 Crimping Cleat	24	Pack	ETC4129	MF <input checked="" type="checkbox"/>
					SA <input type="checkbox"/>
					KL <input type="checkbox"/>
					HP <input type="checkbox"/>
					SSC <input type="checkbox"/>
					SMC <input type="checkbox"/>
					W <input type="checkbox"/>
					Z <input type="checkbox"/>
					PC <input type="checkbox"/>
					PC <input type="checkbox"/>
	ACET4130 Cruciform Block	10	Pack	ETC4130	MF <input checked="" type="checkbox"/>
					SA <input type="checkbox"/>
					KL <input type="checkbox"/>
					HP <input type="checkbox"/>
					SSC <input type="checkbox"/>
					SMC <input type="checkbox"/>
					W <input type="checkbox"/>
					Z <input type="checkbox"/>
					PC <input type="checkbox"/>
					PC <input type="checkbox"/>
	ACET4131 Offset Cruciform Block	10	Pairs	ETC4130	MF <input checked="" type="checkbox"/>
					SA <input type="checkbox"/>
					KL <input type="checkbox"/>
					HP <input type="checkbox"/>
					SSC <input type="checkbox"/>
					SMC <input type="checkbox"/>
					W <input type="checkbox"/>
					Z <input type="checkbox"/>
					PC <input type="checkbox"/>
					PC <input type="checkbox"/>
<p>T-BARS ACVG65=2.5mm ACVG66=3.0mm ACVL150=4.0mm</p> <p>Screw (Grub)</p>	<p>MF = Mill Finish SA = Silver Anodised KL = Basic Colour HP = Special Colour SSC = Smooth Satin Chrome SMC = Smokey Chrome PC = Polished Chrome</p>	<p>W = White Z = Black</p>			

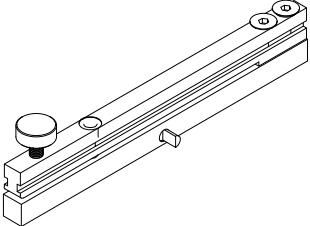
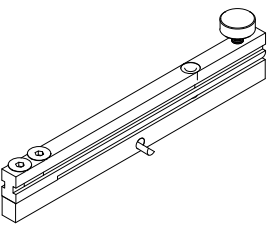
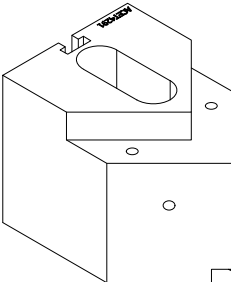
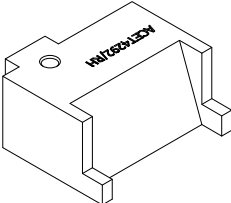
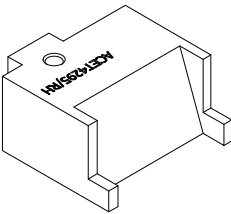


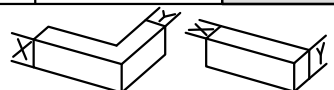
ACCESSORIES : PHOTOS & DRAWINGS

Image	Part Code	Pack	Unit	Application	Colour	
	ACET4135 Cruciform Block	10	Pack	ETC4135	MF	✓
					SA	
					KL	
					HP	
					SSC	
					SMC	
					W	
					Z	
					PC	
						ACET4136 Offset Cruciform Block
SA						
KL						
HP						
SSC						
SMC						
W						
Z						
PC						
	ACET4138 End Cap	1	Pair	ETC4138 ACET4054 ACET4055 ACUN3050		
					SA	
					KL	
					HP	
					SSC	
					SMC	
					W	✓
					Z	✓
					PC	
						ACET4139 End Cap
SA						
KL						
HP						
SSC						
SMC						
W	✓					
Z	✓					
PC						
	ACET4165 Cast Handle Block	1	each	ETC4124 UN3160/G		
					SA	✓
					KL	✓
					HP	
					SSC	
					SMC	✓
					W	✓
					Z	
					PC	
					 <small>T-BARS ACVG65=2.5mm ACVG66=3.0mm ACVL150=4.0mm</small>	 <small>Screw (Grub)</small>

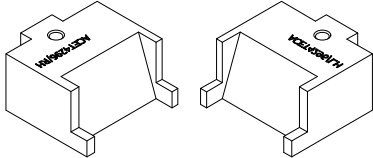
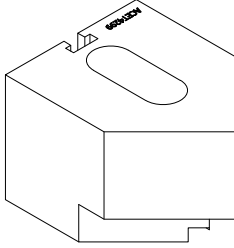
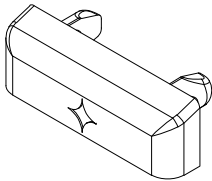
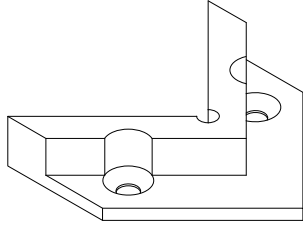
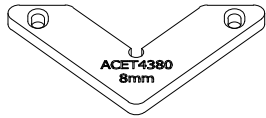

ACCESSORIES : PHOTOS & DRAWINGS

Image	Part Code	Pack	Unit	Application	Colour	
	ACET4170 Foam	1	Each	ETC4111	MF	
					SA	
					KL	
					HP	
					SSC	
					SMC	
					W	
					Z	✓
					PC	
	ACET4180 Run-Up Block	100	Pack	ETC4110 ETC4112 ETC4115	MF	
					SA	
					KL	
					HP	
					SSC	
					SMC	
					W	✓
					Z	✓
					PC	
	ACET4181 Run-Up Block	100	Pack	ETC4146	MF	
					SA	
					KL	
					HP	
					SSC	
					SMC	
					W	✓
					Z	✓
					PC	
	ACET4200 Variable Angle Cleat with screws	24	Pack	ETC4110 ETC4111 ETC4112 ETC4113	MF	✓
					SA	
					KL	
					HP	
					SSC	
					SMC	
					W	
					Z	
					PC	
	ACET4201 Variable Angle Cleat with screws	24	Pack	ETC4110 ETC4111 ETC4112 ETC4113	MF	✓
					SA	
					KL	
					HP	
					SSC	
					SMC	
					W	
					Z	
					PC	
 <p>T-BARS ACVG65=2.5mm ACVG66=3.0mm ACVL150=4.0mm</p> <p>Screw (Grub)</p>	MF = Mill Finish SA = Silver Anodised KL = Basic Colour HP = Special Colour SSC = Smooth Satin Chrome SMC = Smokey Chrome PC = Polished Chrome	W = White Z = Black				




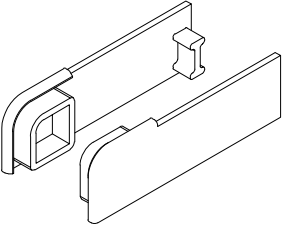
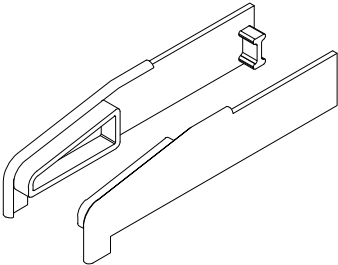



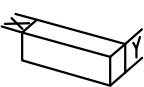
ACCESSORIES : PHOTOS & DRAWINGS

Image	Part Code	Pack	Unit	Application	Colour
	ACET4208 Jig for Variable Angle Cleat for ACET4200	1	Each	ETC4110 ETC4111 ETC4112 ETC4113	MF <input checked="" type="checkbox"/> SA <input type="checkbox"/> KL <input type="checkbox"/> HP <input type="checkbox"/> SSC <input type="checkbox"/> SMC <input type="checkbox"/> W <input type="checkbox"/> Z <input type="checkbox"/> PC <input type="checkbox"/>
	ACET4209 Jig for Variable Angle Cleat for ACET4201	1	Each	ETC4110 ETC4111 ETC4112 ETC4113	MF <input checked="" type="checkbox"/> SA <input type="checkbox"/> KL <input type="checkbox"/> HP <input type="checkbox"/> SSC <input type="checkbox"/> SMC <input type="checkbox"/> W <input type="checkbox"/> Z <input type="checkbox"/> PC <input type="checkbox"/>
	ACET4291N Vee Block	1	Each	ETC4110 ETC4112 ETC4115 ETC4120 ETC4146 ETC4147	MF <input checked="" type="checkbox"/> SA <input type="checkbox"/> KL <input type="checkbox"/> HP <input type="checkbox"/> SSC <input type="checkbox"/> SMC <input type="checkbox"/> W <input type="checkbox"/> Z <input type="checkbox"/> PC <input type="checkbox"/>
	ACET4292 Punches	1	Each	ETC4110 ETC4111 ETC4112 ETC4113	MF <input checked="" type="checkbox"/> SA <input type="checkbox"/> KL <input type="checkbox"/> HP <input type="checkbox"/> SSC <input type="checkbox"/> SMC <input type="checkbox"/> W <input type="checkbox"/> Z <input type="checkbox"/> PC <input type="checkbox"/>
	ACET4295 Punches	1	Each	ETC4115 ETC4120	MF <input checked="" type="checkbox"/> SA <input type="checkbox"/> KL <input type="checkbox"/> HP <input type="checkbox"/> SSC <input type="checkbox"/> SMC <input type="checkbox"/> W <input type="checkbox"/> Z <input type="checkbox"/> PC <input type="checkbox"/>
 	MF = Mill Finish SA = Silver Anodised KL = Basic Colour HP = Special Colour SSC = Smooth Satin Chrome SMC = Smokey Chrome PC = Polished Chrome	W = White Z = Black			

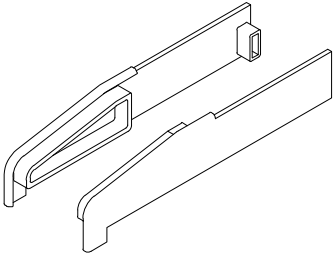
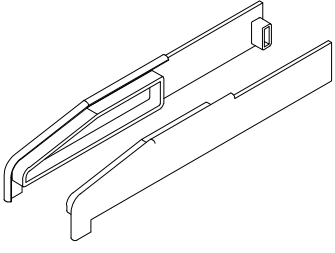


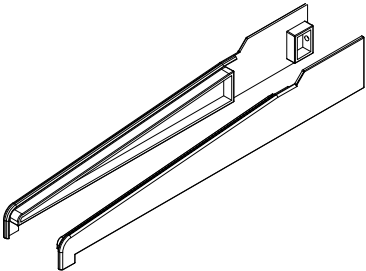


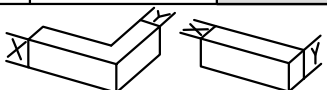
ACCESSORIES : PHOTOS & DRAWINGS

Image	Part Code	Pack	Unit	Application	Colour
	ACET4296 Punches	1	Each	ETC4129 ETC4146 ETC4147	MF <input checked="" type="checkbox"/>
					SA <input type="checkbox"/>
					KL <input type="checkbox"/>
					HP <input type="checkbox"/>
					SSC <input type="checkbox"/>
					SMC <input type="checkbox"/>
					W <input type="checkbox"/>
					Z <input type="checkbox"/>
					PC <input type="checkbox"/>
					
SA <input type="checkbox"/>					
KL <input type="checkbox"/>					
HP <input type="checkbox"/>					
SSC <input type="checkbox"/>					
SMC <input type="checkbox"/>					
W <input type="checkbox"/>					
Z <input type="checkbox"/>					
PC <input type="checkbox"/>					
	ACET432 Drainage Cover Cap (Colour Match)	8	Pack	ETC4110 ETC4111 ETC4112 ETC4113 ETC4115 ETC4130 ETC4135 UN3000	
					SA <input type="checkbox"/>
					KL <input checked="" type="checkbox"/>
					HP <input checked="" type="checkbox"/>
					SSC <input type="checkbox"/>
					SMC <input type="checkbox"/>
					W <input checked="" type="checkbox"/>
					Z <input checked="" type="checkbox"/>
					PC <input type="checkbox"/>
					
SA <input type="checkbox"/>					
KL <input type="checkbox"/>					
HP <input type="checkbox"/>					
SSC <input type="checkbox"/>					
SMC <input type="checkbox"/>					
W <input type="checkbox"/>					
Z <input type="checkbox"/>					
PC <input type="checkbox"/>					
	ACET4380 8mm Crimping Support	1	Each	ETC4115G ETC4116G	
					SA <input type="checkbox"/>
					KL <input type="checkbox"/>
					HP <input type="checkbox"/>
					SSC <input type="checkbox"/>
					SMC <input type="checkbox"/>
					W <input type="checkbox"/>
					Z <input type="checkbox"/>
					PC <input type="checkbox"/>
					 T-BARS ACVG66=2.5mm ACVG66=3.0mm ACVL150=4.0mm

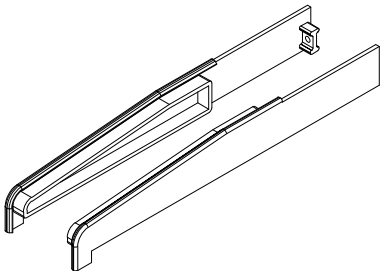
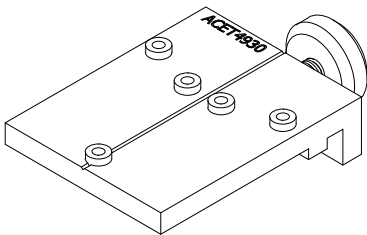
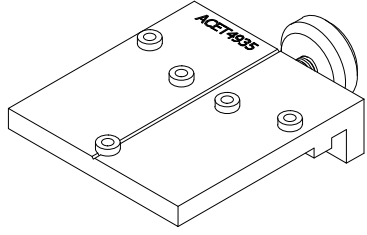
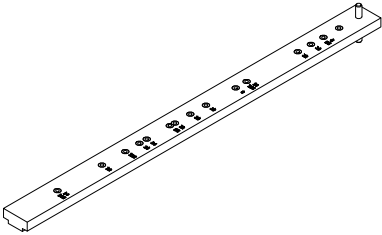
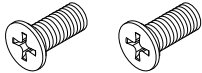


ACCESSORIES : PHOTOS & DRAWINGS

Image	Part Code	Pack	Unit	Application	Colour
 <p>ACET4381 10mm</p>	ACET4381 10mm Crimping Support	1	Each	ETC4110G ETC4111G ETC4112G ETC4115G ETC4116G ETC4124G ETC4129G ETC4146G	MF <input checked="" type="checkbox"/>
					SA <input type="checkbox"/>
					KL <input type="checkbox"/>
					HP <input type="checkbox"/>
					SSC <input type="checkbox"/>
					SMC <input type="checkbox"/>
					W <input type="checkbox"/>
					Z <input type="checkbox"/>
					PC <input type="checkbox"/>
					PC <input type="checkbox"/>
 <p>ACET4382 14.5mm</p>	ACET4382 14.5mm Crimping Support	1	Each	ETC4110G ETC4111G ETC4112G ETC4120G ETC4124G ETC4129G ETC4146G	MF <input checked="" type="checkbox"/>
					SA <input type="checkbox"/>
					KL <input type="checkbox"/>
					HP <input type="checkbox"/>
					SSC <input type="checkbox"/>
					SMC <input type="checkbox"/>
					W <input type="checkbox"/>
					Z <input type="checkbox"/>
					PC <input type="checkbox"/>
					PC <input type="checkbox"/>
 <p>ACET4383 22.5mm</p>	ACET4383 22.5mm Crimping Support	1	Each	ETC4120G ETC4125G	MF <input checked="" type="checkbox"/>
					SA <input type="checkbox"/>
					KL <input type="checkbox"/>
					HP <input type="checkbox"/>
					SSC <input type="checkbox"/>
					SMC <input type="checkbox"/>
					W <input type="checkbox"/>
					Z <input type="checkbox"/>
					PC <input type="checkbox"/>
					PC <input type="checkbox"/>
	ACET451 Cill End Cap	1	Pair	ETC451	MF <input checked="" type="checkbox"/>
					SA <input type="checkbox"/>
					KL <input checked="" type="checkbox"/>
					HP <input checked="" type="checkbox"/>
					SSC <input type="checkbox"/>
					SMC <input type="checkbox"/>
					W <input checked="" type="checkbox"/>
					Z <input checked="" type="checkbox"/>
					PC <input type="checkbox"/>
					PC <input type="checkbox"/>
	ACET452 Cill End Cap	1	Pair	ETC452	MF <input checked="" type="checkbox"/>
					SA <input type="checkbox"/>
					KL <input checked="" type="checkbox"/>
					HP <input checked="" type="checkbox"/>
					SSC <input type="checkbox"/>
					SMC <input type="checkbox"/>
					W <input checked="" type="checkbox"/>
					Z <input checked="" type="checkbox"/>
					PC <input type="checkbox"/>
					PC <input type="checkbox"/>
 <p>T-BARS ACVG65=2.5mm ACVG66=3.0mm ACVL150=4.0mm</p>  <p>Screw (Grub)</p>	MF = Mill Finish SA = Silver Anodised KL = Basic Colour HP = Special Colour SSC = Smooth Satin Chrome SMC = Smokey Chrome PC = Polished Chrome	W = White Z = Black	 		

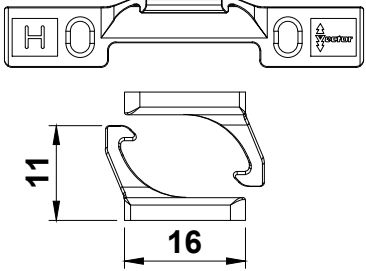
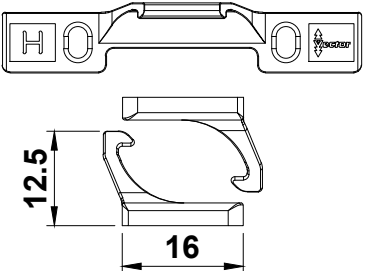
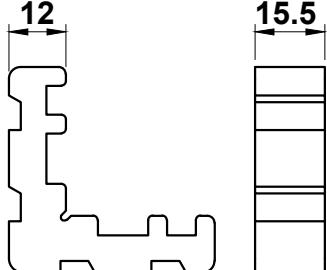
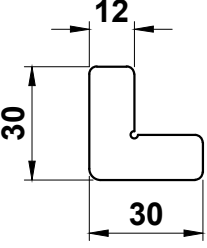
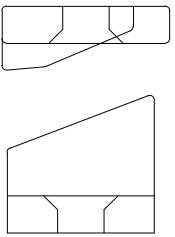


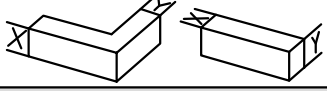
ACCESSORIES : PHOTOS & DRAWINGS

Image	Part Code	Pack	Unit	Application	Colour	
	ACET457 Cill End Cap	1	Pair	ETC457	MF	✓
					SA	
					KL	✓
					HP	✓
					SSC	
					SMC	
					W	✓
					Z	✓
					PC	
	ACET458 Cill End Cap	1	Pair	ETC458	MF	✓
					SA	
					KL	✓
					HP	✓
					SSC	
					SMC	
					W	✓
					Z	✓
					PC	
	ACET460 Inline Espag Handle with 9mm Spindle	1	Each	ACET4001 to AET4006	MF	
					SA	
					KL	✓
					HP	✓
					SSC	✓
					SMC	✓
					W	✓
					Z	✓
					PC	✓
	ACET465 Cranked Espag Handle with 9mm Spindle	1	Each	ACET4001 to AET4006	MF	
					SA	
					KL	✓
					HP	✓
					SSC	✓
					SMC	✓
					W	✓
					Z	✓
					PC	✓
	ACET477 Cill End Cap	1	Pair	ETC477	MF	✓
					SA	
					KL	✓
					HP	✓
					SSC	
					SMC	
					W	✓
					Z	✓
					PC	
 T-BARS ACVG66=2.5mm ACVG66=3.0mm ACVL150=4.0mm	 Screw (Grub)	MF = Mill Finish SA = Silver Anodised KL = Basic Colour HP = Special Colour SSC = Smooth Satin Chrome SMC = Smokey Chrome PC = Polished Chrome	W = White Z = Black			

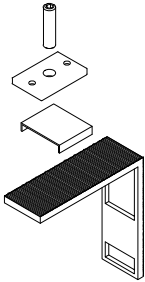
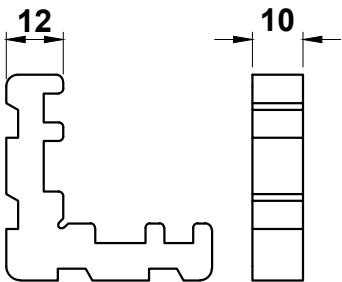
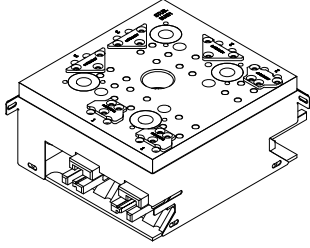
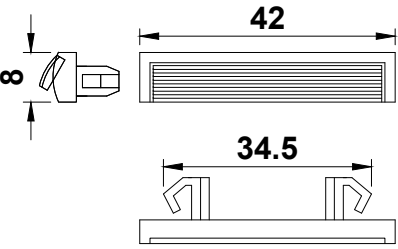
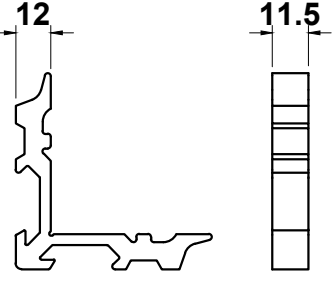

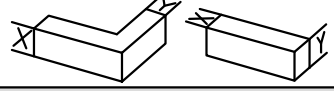
ACCESSORIES : PHOTOS & DRAWINGS

Image	Part Code	Pack	Unit	Application	Colour	
	ACET479N Cill End Cap	1	Pair	ETC479N	MF	✓
					SA	
					KL	✓
					HP	✓
					SSC	
					SMC	
					W	✓
					Z	✓
					PC	
						ACET4930 Drill Jig
SA						
KL						
HP						
SSC						
SMC						
W						
Z						
PC						
	ACET4935 Drill Jig	1	Pair	ACET4135 ETC4135		
					SA	
					KL	
					HP	
					SSC	
					SMC	
					W	
					Z	
					PC	
						ACET4904 Drill Jig
SA						
KL						
HP						
SSC						
SMC						
W						
Z						
PC						
	ACET495 Handle Fixing Kit 1 Pack Contains: 2No. 5 x 12 SS CSK Machine Screws	1	Pack	ACET460 ACET465		
					SA	
					KL	
					HP	
					SSC	
					SMC	
					W	
					Z	
					PC	
					 <p>T-BARS ACVG65=2.5mm ACVG66=3.0mm ACVL150=4.0mm</p>  <p>Screw (Grub)</p>	MF = Mill Finish SA = Silver Anodised KL = Basic Colour HP = Special Colour SSC = Smooth Satin Chrome SMC = Smokey Chrome PC = Polished Chrome

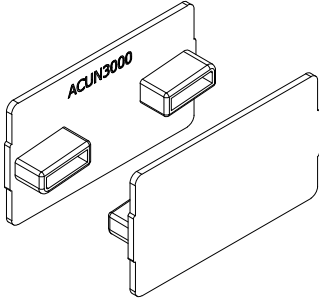
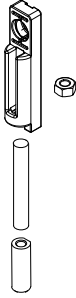
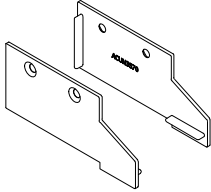
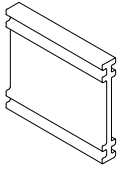
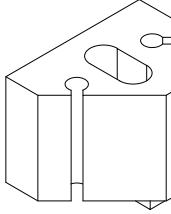


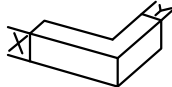
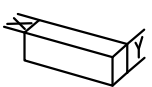
ACCESSORIES : PHOTOS & DRAWINGS

Image	Part Code	Pack	Unit	Application	
 <p>11 16</p>	ACET513 13mm Cavity Hinge Protector 4 Per Set (2 pairs)	50	Sets	ETC4124 ETC4125	MF <input checked="" type="checkbox"/>
					SA <input type="checkbox"/>
					KL <input type="checkbox"/>
					HP <input type="checkbox"/>
					SSC <input type="checkbox"/>
					SMC <input type="checkbox"/>
					W <input type="checkbox"/>
					Z <input type="checkbox"/>
					PC <input type="checkbox"/>
 <p>12.5 16</p>	ACET516 16mm Cavity Hinge Protector 4 Per Set (2 pairs)	50	Sets	ETC4120 ETC4129	MF <input checked="" type="checkbox"/>
					SA <input type="checkbox"/>
					KL <input type="checkbox"/>
					HP <input type="checkbox"/>
					SSC <input type="checkbox"/>
					SMC <input type="checkbox"/>
					W <input type="checkbox"/>
					Z <input type="checkbox"/>
					PC <input type="checkbox"/>
 <p>12 15.5</p>	ACET615 Crimping Cleat	24	Pack	ETC4146	MF <input checked="" type="checkbox"/>
					SA <input type="checkbox"/>
					KL <input type="checkbox"/>
					HP <input type="checkbox"/>
					SSC <input type="checkbox"/>
					SMC <input type="checkbox"/>
					W <input type="checkbox"/>
					Z <input type="checkbox"/>
					PC <input type="checkbox"/>
 <p>12 30 30</p>	ACET624 Stainless Steel Chevron	100	Pack	ETC4120 ETC4129	MF <input type="checkbox"/>
					SA <input type="checkbox"/>
					KL <input type="checkbox"/>
					HP <input type="checkbox"/>
					SSC <input type="checkbox"/>
					SMC <input type="checkbox"/>
					W <input type="checkbox"/>
					Z <input type="checkbox"/>
					PC <input type="checkbox"/>
	ACET652 Pull-In Blocks	50	Pack	ETC4120 ETC4129	MF <input type="checkbox"/>
					SA <input type="checkbox"/>
					KL <input type="checkbox"/>
					HP <input type="checkbox"/>
					SSC <input type="checkbox"/>
					SMC <input type="checkbox"/>
					W <input checked="" type="checkbox"/>
					Z <input checked="" type="checkbox"/>
					PC <input type="checkbox"/>
 <p>T-BARS ACVG65=2.5mm ACVG66=3.0mm ACVL150=4.0mm</p>  <p>Screw (Grub)</p>	MF = Mill Finish SA = Silver Anodised KL = Basic Colour HP = Special Colour SSC = Smooth Satin Chrome SMC = Smokey Chrome PC = Polished Chrome	W = White Z = Black			

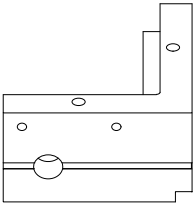
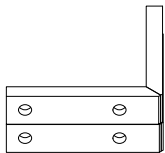
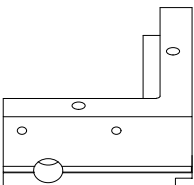
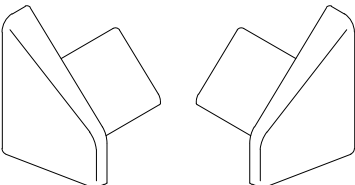
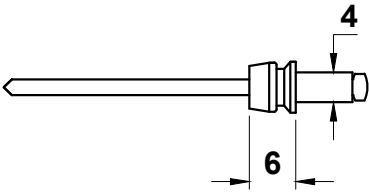



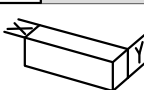
ACCESSORIES : PHOTOS & DRAWINGS

Image	Part Code	Pack	Unit	Application	
	ACET695 Glass Adjuster Kit Kit Includes: 1 x Adjusting Screw 1 x Threaded Block 1 x Steel Cover 1 x ABS Corner	1	Kit	ETC4129	MF SA KL HP SSC SMC W Z PC
	ACET820 Crimping Cleat	24	Pack	ETC4110 ETC4111 ETC4112 ETC4113 ETC4120 ETC4129	MF ✓ SA KL HP SSC SMC W Z PC
	ACET963 Punch Tool	1	Each	ETC4110 ETC4112 ETC4115 ETC4129 ETC4146	MF SA KL HP SSC SMC W Z PC
	ACGSL045 Drainage Cap	100	Pack		MF SA KL HP SSC SMC W ✓ Z ✓ PC
	ACSL013B Mechanical Cleat	24	Pack	ETC4110 ETC4112 ETC4115	MF ✓ SA KL HP SSC SMC W Z PC
	MF = Mill Finish SA = Silver Anodised KL = Basic Colour HP = Special Colour SSC = Smooth Satin Chrome SMC = Smokey Chrome PC = Polished Chrome	W = White Z = Black			

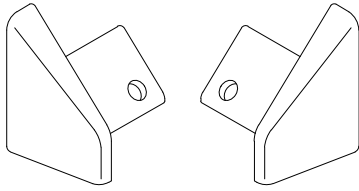
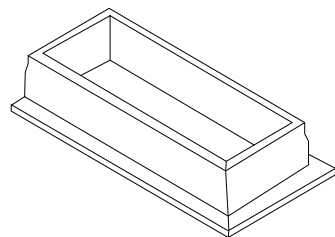
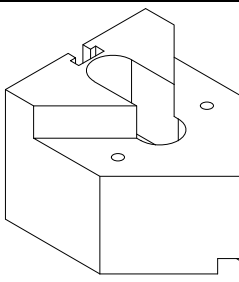
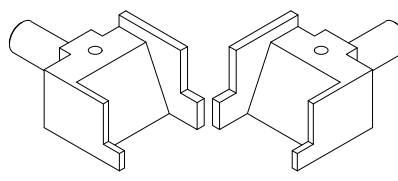
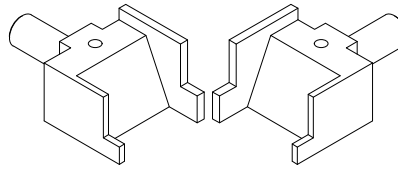


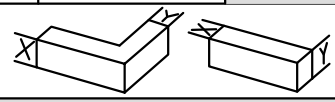
ACCESSORIES : PHOTOS & DRAWINGS

Image	Part Code	Pack	Unit	Application		
	ACUN3000 End Caps for UN3000	10	Pairs	UN3000	MF	
					SA	
					KL	
					HP	
					SSC	
					SMC	
					W	
					Z	✓
					PC	
	ACUN3055 French Casement Shootbolt Kit Includes: 2 x Cam connectors 2 x 180mm SS threaded bar 2 x Stainless Steel Shootbolt 2 x M8 Nuts	1	Kit	ETC4138 ACET4054 ACET4055 ACET4138	MF	
					SA	
					KL	
					HP	
					SSC	
					SMC	
					W	
					Z	
					PC	
	ACUN3570 UN3570 End Caps	1	Pair	UN3570	MF	
					SA	
					KL	
					HP	
					SSC	
					SMC	
					W	✓
					Z	✓
					PC	
	ACUN3701 Anti-Crush Support	25	Pack	UN3570	MF	
					SA	
					KL	
					HP	
					SSC	
					SMC	
					W	
					Z	
					PC	
	ACUN3950 Vee Block	1	Each	ACUN3951 ACUN3952 ACUN3953 'G' Profiles	MF	
					SA	
					KL	
					HP	
					SSC	
					SMC	
					W	
					Z	
					PC	
 T-BARS ACVG66=2.5mm ACVG66=3.0mm ACVL150=4.0mm	 Screw (Grub)	MF = Mill Finish SA = Silver Anodised KL = Basic Colour HP = Special Colour SSC = Smooth Satin Chrome SMC = Smokey Chrome PC = Polished Chrome	W = White Z = Black	 		

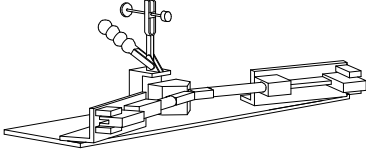


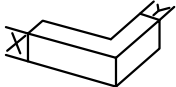
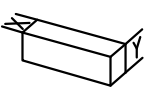
ACCESSORIES : PHOTOS & DRAWINGS

Image	Part Code	Pack	Unit	Application		
	ACUN3951 ACUN3950 Faceplate	1	Each	ACUN3950 ACUN3952 'G' Profiles (not ETC4129)	MF	
					SA	
					KL	
					HP	
					SSC	
					SMC	
					W	
					Z	
					PC	
	ACUN3952 ACUN3950 Nylon Support	1	Each	ACUN3950 ACUN3951 ACUN3953 'G' Profiles	MF	
					SA	
					KL	
					HP	
					SSC	
					SMC	
					W	
					Z	
					PC	
	ACUN3953 ACUN3950 Faceplate	1	Each	ACUN3950 ACUN3952 ACUN3953 ETC4129G	MF	
					SA	
					KL	
					HP	
					SSC	
					SMC	
					W	
					Z	
					PC	
	ACVL059 End Cap	1	Pair	VL72	MF	
					SA	
					KL	
					HP	
					SSC	
					SMC	
					W	✓
					Z	✓
					PC	
	ACVL061 Rivet	100	Pack	VL72	MF	✓
					SA	
					KL	
					HP	
					SSC	
					SMC	
					W	
					Z	
					PC	
 <p>T-BARS ACVG65=2.5mm ACVG66=3.0mm ACVL150=4.0mm</p>  <p>Screw (Grub)</p>	MF = Mill Finish SA = Silver Anodised KL = Basic Colour HP = Special Colour SSC = Smooth Satin Chrome SMC = Smokey Chrome PC = Polished Chrome	W = White Z = Black	 			

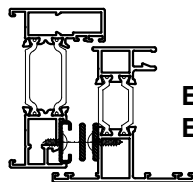
ACCESSORIES : PHOTOS & DRAWINGS

Image	Part Code	Pack	Unit	Application	
	ACVL072 Cast End Cap	1	Pair	VL72	MF <input checked="" type="checkbox"/>
					SA <input type="checkbox"/>
					KL <input checked="" type="checkbox"/>
					HP <input checked="" type="checkbox"/>
					SSC <input type="checkbox"/>
					SMC <input type="checkbox"/>
					W <input checked="" type="checkbox"/>
					Z <input checked="" type="checkbox"/>
					PC <input type="checkbox"/>
	ACVL635 PVC End Cap	1	each	ETC4136	MF <input type="checkbox"/>
					SA <input type="checkbox"/>
					KL <input type="checkbox"/>
					HP <input type="checkbox"/>
					SSC <input type="checkbox"/>
					SMC <input type="checkbox"/>
					W <input type="checkbox"/>
					Z <input checked="" type="checkbox"/>
					PC <input type="checkbox"/>
	ACW906 Vee Block	1	Each	ETC4124	MF <input type="checkbox"/>
					SA <input type="checkbox"/>
					KL <input type="checkbox"/>
					HP <input type="checkbox"/>
					SSC <input type="checkbox"/>
					SMC <input type="checkbox"/>
					W <input type="checkbox"/>
					Z <input type="checkbox"/>
					PC <input type="checkbox"/>
	ACW906 Punches	1	Pair	ETC4124	MF <input type="checkbox"/>
					SA <input type="checkbox"/>
					KL <input type="checkbox"/>
					HP <input type="checkbox"/>
					SSC <input type="checkbox"/>
					SMC <input type="checkbox"/>
					W <input type="checkbox"/>
					Z <input type="checkbox"/>
					PC <input type="checkbox"/>
	ACW909 Punches	1	Pair	ETC4124	MF <input type="checkbox"/>
					SA <input type="checkbox"/>
					KL <input type="checkbox"/>
					HP <input type="checkbox"/>
					SSC <input type="checkbox"/>
					SMC <input type="checkbox"/>
					W <input type="checkbox"/>
					Z <input type="checkbox"/>
					PC <input type="checkbox"/>
 <small>T-BARS ACVG65=2.5mm ACVG66=3.0mm ACVL150=4.0mm</small>	 <small>Screw (Grub)</small>	MF = Mill Finish SA = Silver Anodised KL = Basic Colour HP = Special Colour SSC = Smooth Satin Chrome SMC = Smokey Chrome PC = Polished Chrome	W = White Z = Black		

ACCESSORIES : PHOTOS & DRAWINGS

Image	Part Code	Pack	Unit	Application																			
	<p>WUT024HSZA</p> <p>Manual Crimper</p> <p>Note: Vee Blocks & Punches are Sold Separately</p>	1	Each		<table border="1"> <tr><td>MF</td><td></td></tr> <tr><td>SA</td><td></td></tr> <tr><td>KL</td><td></td></tr> <tr><td>HP</td><td></td></tr> <tr><td>SSC</td><td></td></tr> <tr><td>SMC</td><td></td></tr> <tr><td>W</td><td></td></tr> <tr><td>Z</td><td></td></tr> <tr><td>PC</td><td></td></tr> </table>	MF		SA		KL		HP		SSC		SMC		W		Z		PC	
MF																							
SA																							
KL																							
HP																							
SSC																							
SMC																							
W																							
Z																							
PC																							
					<table border="1"> <tr><td>MF</td><td></td></tr> <tr><td>SA</td><td></td></tr> <tr><td>KL</td><td></td></tr> <tr><td>HP</td><td></td></tr> <tr><td>SSC</td><td></td></tr> <tr><td>SMC</td><td></td></tr> <tr><td>W</td><td></td></tr> <tr><td>Z</td><td></td></tr> <tr><td>PC</td><td></td></tr> </table>	MF		SA		KL		HP		SSC		SMC		W		Z		PC	
MF																							
SA																							
KL																							
HP																							
SSC																							
SMC																							
W																							
Z																							
PC																							
					<table border="1"> <tr><td>MF</td><td></td></tr> <tr><td>SA</td><td></td></tr> <tr><td>KL</td><td></td></tr> <tr><td>HP</td><td></td></tr> <tr><td>SSC</td><td></td></tr> <tr><td>SMC</td><td></td></tr> <tr><td>W</td><td></td></tr> <tr><td>Z</td><td></td></tr> <tr><td>PC</td><td></td></tr> </table>	MF		SA		KL		HP		SSC		SMC		W		Z		PC	
MF																							
SA																							
KL																							
HP																							
SSC																							
SMC																							
W																							
Z																							
PC																							
					<table border="1"> <tr><td>MF</td><td></td></tr> <tr><td>SA</td><td></td></tr> <tr><td>KL</td><td></td></tr> <tr><td>HP</td><td></td></tr> <tr><td>SSC</td><td></td></tr> <tr><td>SMC</td><td></td></tr> <tr><td>W</td><td></td></tr> <tr><td>Z</td><td></td></tr> <tr><td>PC</td><td></td></tr> </table>	MF		SA		KL		HP		SSC		SMC		W		Z		PC	
MF																							
SA																							
KL																							
HP																							
SSC																							
SMC																							
W																							
Z																							
PC																							
					<table border="1"> <tr><td>MF</td><td></td></tr> <tr><td>SA</td><td></td></tr> <tr><td>KL</td><td></td></tr> <tr><td>HP</td><td></td></tr> <tr><td>SSC</td><td></td></tr> <tr><td>SMC</td><td></td></tr> <tr><td>W</td><td></td></tr> <tr><td>Z</td><td></td></tr> <tr><td>PC</td><td></td></tr> </table>	MF		SA		KL		HP		SSC		SMC		W		Z		PC	
MF																							
SA																							
KL																							
HP																							
SSC																							
SMC																							
W																							
Z																							
PC																							
 <p>T-BARS ACVG65=2.5mm ACVG66=3.0mm ACVL150=4.0mm</p>  <p>Screw (Grub)</p>	<p>MF = Mill Finish SA = Silver Anodised KL = Basic Colour HP = Special Colour SSC = Smooth Satin Chrome SMC = Smokey Chrome PC = Polished Chrome</p> <p>W = White Z = Black</p>			 																			

16mm Stack Friction Hinge Stays



ETC4120
ETC4129

Friction Hinge Stays 16mm Stack (Standard)

Top Hung Windows

Top Hung	Type of Hinge / Stay	Max. Vent	Height		Opening Angle (+/- 2.5°)
		Weight (kgs)	Minimum	Maximum	
ACETDHS08	Standard	12	200	350	65°
ACETDHS10		16	275	400	80°
ACETDHS12		20	350	550	80°
ACETDHS16		21	500	780	80°
ACETDHS20		26	700	1100	50°
ACETDHS24		40	850	1300	37.5°
ACETDTH24	Heavy Duty	50	850	1500	32°
ACETDHS12R	Restricted	20	350	550	14° / 65°
ACETDHS16R		21	500	780	10° / 59°
ACETDHS20R		26	700	1100	8° / 50°
ACETDHS24R		40	850	1300	7° / 37.5°

Side Hung Windows

Side Hung	Type of Hinge / Stay	Max. Vent	Width ('A')		Opening Angle (+/- 2.5°)
		Weight (kgs)	Minimum	Maximum	
ACETDSSH12	Standard	22	300	600	60°
ACETDSSH16		24	400	600	60°
ACETSH1612L ACETSH1612R	Restricted Left Hand R/H Non-Restricted Right Hand L/H Non-Restricted	22	300	600	13°/58°
ACETSH1616L ACETSH1616R	VIEWED FROM OUTSIDE L/H Restricted R/H Restricted	24	400	600	11°/58°
ACETME16	Egress *use with ACET652 pull in blocks	40	365	865	90°
ACETDSH16	Heavy Duty	40	400	1000	60°

Note1: Vent Height / Width is measured in mm from rebate to rebate (not overall size or outer frame)

Note2: Top hung height and side hung width sizes to be reduced by 2mm where size is 450mm or smaller

Note3: Typical Dimensions based on Max. Size and Glass 30kg/metre

Note4: For additional security use ACET516 hinge protectors

Note5: Kitemark specification covers Top Hung Max. height up to 1400mm.

Note6: For sashes over 600mm, ACETME99 is recommended for ACETME16 to disable easy clean function



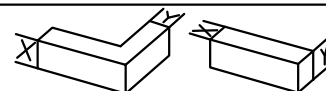
T-BARS
ACVG65=2.5mm
ACVG66=3.0mm
ACVL150=4.0mm



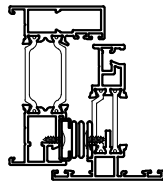
Screw (Grub)

MF = Mill Finish
SA = Silver Anodised
KL = Basic Colour
HP = Special Colour
SSC = Smooth Satin Chrome
SMC = Smokey Chrome
PC = Polished Chrome

W = White
Z = Black



13mm Stack Friction Hinge Stays



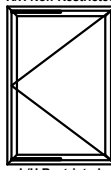
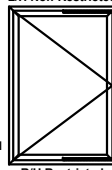
ETC4124
ETC4125

Friction Hinge Stays 13mm Stack (Standard)

Top Hung Windows

Top Hung	Type of Hinge / Stay	Max. Vent	Height ('A')		Opening Angle (+/- 2.5°)
		Weight (kgs)	Minimum	Maximum	
ACINDS10	Standard	16	275	400	80°
ACINDS16		21	400	780	80°
ACINDS20		26	700	1100	50°
ACINDS24		40	850	1300	37.5°
ACINDP24	Heavy Duty	50	850	1500	32°
ACINDA10	Austenitic	16	275	400	80°
ACINDA16		21	400	780	80°
ACINDA20		26	700	1100	50°
ACINDA24		40	850	1300	37.5°
ACINDR12	Restricted	20	350	550	14°/65°
ACINDR16		21	500	780	10°/59°
ACINDR20		26	700	1100	8°/50°
ACINDR24		40	850	1300	7°/37.5°

Side Hung Windows

Side Hung	Type of Hinge / Stay	Max. Vent	Width ('A')		Opening Angle (+/- 2.5°)
		Weight (kgs)	Minimum	Maximum	
ACINDSSH12	Standard	22	300	600	60°
ACINDSSH16		24	400	600	60°
ACINDASH12	Austenitic	22	300	600	60°
ACINDASH16		24	400	600	60°
ACETSH1312L ACETSH1312R	Restricted Left Hand R/H Non-Restricted  Right Hand L/H Non-Restricted 	22	300	600	13°/58°
ACETSH1316L ACETSH1316R	VIEWED FROM OUTSIDE L/H Restricted R/H Restricted	24	400	600	11°/58°
ACETME13	Egress *use with ACET352 pull in blocks	40	365	865	90°

Note1: Vent Height / Width is measured in mm from rebate to rebate (not overall size or outer frame)

Note2: Top hung height and side hung width sizes to be reduced by 2mm where size is 450mm or smaller

Note3: Typical Dimensions based on Max. Size and Glass 30kg/metre

Note4: For additional security use ACET513 hinge protectors

Note5: Kitemark specification covers Top Hung Max. height up to 1400mm. ACINDP24 Max. height is 1500mm

Note6: For sashes over 600mm, ACETME99 is recommended for ACETME13 to disable easy clean function



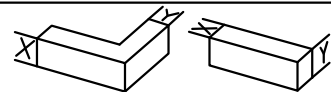
T-BARS
ACVG85=2.5mm
ACVG66=3.0mm
ACVL150=4.0mm



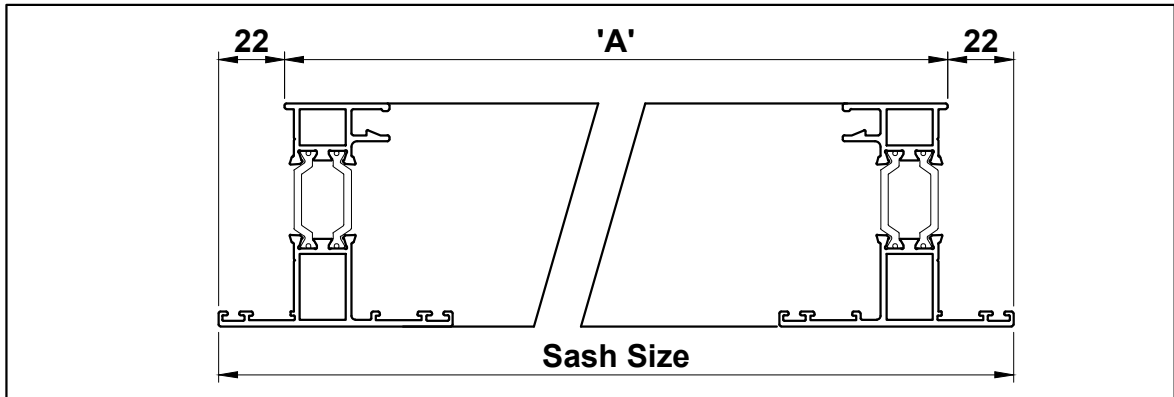
Screw (Grub)

MF = Mill Finish
SA = Silver Anodised
KL = Basic Colour
HP = Special Colour
SSC = Smooth Satin Chrome
SMC = Smokey Chrome
PC = Polished Chrome

W = White
Z = Black

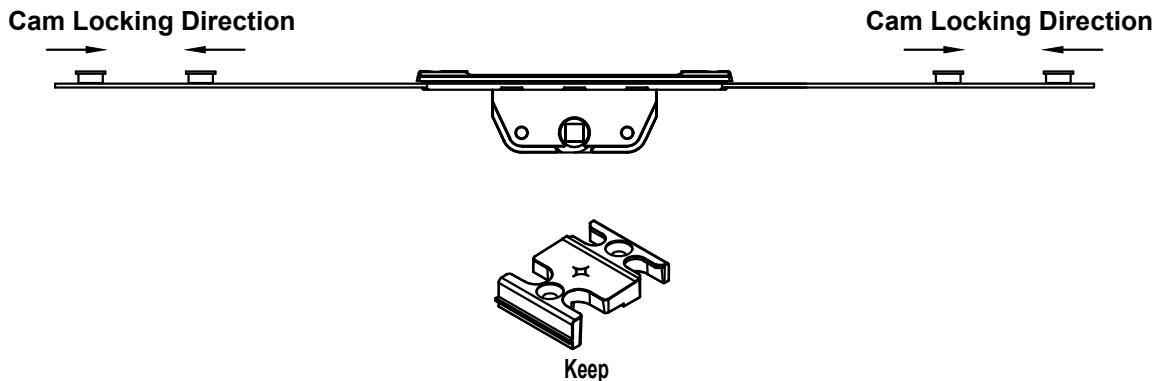


Reverse Espag Locking



Part Code	Rod Length (mm)	Number of Keeps	Sash Rebate Size ('A')		Pack QTY
			Minimum	Maximum	
ACET4001L	335	2	340	505	20
ACET4001R					
ACET4002L	500	2	506	755	20
ACET4002R					
ACET4003L	750	2	756	1005	20
ACET4003R					
ACET4004L	1000	4	1006	1255	20
ACET4004R					
ACET4005L	1250	4	1256	1400	20
ACET4005R					

Note: To Suit Handles with 7mm x 7mm spindle



T-BARS
ACVG65=2.5mm
ACVG66=3.0mm
ACVL150=4.0mm



Screw (Grub)

MF = Mill Finish
SA = Silver Anodised
KL = Basic Colour
HP = Special Colour
SSC = Smooth Satin Chrome
SMC = Smokey Chrome
PC = Polished Chrome

W = White
Z = Black

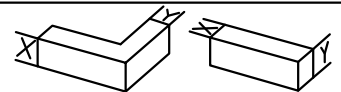


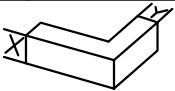
Image	Part Code	Pack	Unit	Application	Colour
	ACMX09761 Maxi Gloss	1	each		MF SA KL HP SSC SMC W Z PC
	ACMX09762 Alu. Bright	1	each		MF SA KL HP SSC SMC W Z PC
	ACMX09763 Teflon Spray	1	each		MF SA KL HP SSC SMC W Z PC
	ACMX09764 Maxi Clean	1	each		MF SA KL HP SSC SMC W Z PC
	ACMX09765 Alu. Cleaner	1	each		MF SA KL HP SSC SMC W Z PC
 <p>T-BARS ACVG65=2.5mm ACVG66=3.0mm ACVL150=4.0mm</p>  <p>Screw (Grub)</p>	<p>MF = Mill Finish SA = Silver Anodised KL = Basic Colour HP = Special Colour SSC = Smooth Satin Chrome SMC = Smokey Chrome PC = Polished Chrome</p>	<p>W = White Z = Black</p>	 		




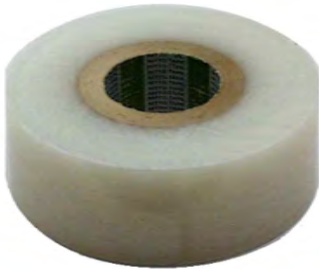
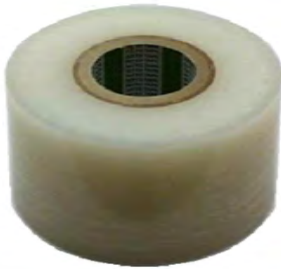



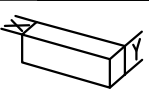
Image	Part Code	Pack	Unit	Application	Colour
	ACMX09770 Roll & Wrap 100mm	1	each		MF
					SA
					KL
					HP
					SSC
					SMC
					W
					Z
					PC
	ACMX09775 Grip Handwrap	1	each		MF
					SA
					KL
					HP
					SSC
					SMC
					W
					Z
					PC
	ACMX09801 Protective Tape 50mm	1	each		MF
					SA
					KL
					HP
					SSC
					SMC
					W
					Z
					PC
	ACMX09802 Protective Tape 70mm	1	each		MF
					SA
					KL
					HP
					SSC
					SMC
					W
					Z
					PC
	ACMX09803 Protective Tape 100mm	1	each		MF
					SA
					KL
					HP
					SSC
					SMC
					W
					Z
					PC
 T-BARS ACVG65=2.5mm ACVG66=3.0mm ACVL150=4.0mm	 Screw (Grub)	MF = Mill Finish SA = Silver Anodised KL = Basic Colour HP = Special Colour SSC = Smooth Satin Chrome SMC = Smokey Chrome PC = Polished Chrome	W = White Z = Black	 	

Image	Part Code	Pack	Unit	Application	Colour
	ACMX09830 Rubber Sealant	1	each		MF SA KL HP SSC SMC W Z PC
	ACSIL04 Sealing Glue Order with suffix of KL colour (eg.ACSIL04KL005) or BL=Black/WP=White/ CL=Clear	1	each		MF SA KL ✓ HP SSC SMC W ✓ Z ✓ PC
	ACSIL08 Silicon Gun	1	each		MF SA KL HP SSC SMC W Z PC
	ACSIL013 Glue for Mitre	1	each		MF SA KL HP SSC SMC W Z PC
	ACSIL014 Anti-Corrosion Coating	1	each		MF ✓ SA KL HP SSC SMC W Z PC
 <p>T-BARS ACVG65=2.5mm ACVG66=3.0mm ACVL150=4.0mm</p>  <p>Screw (Grub)</p>	<p>MF = Mill Finish SA = Silver Anodised KL = Basic Colour HP = Special Colour SSC = Smooth Satin Chrome SMC = Smokey Chrome PC = Polished Chrome</p> <p>W = White Z = Black</p>	 			

STANDARD ACCESSORIES


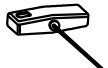


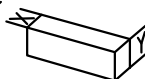


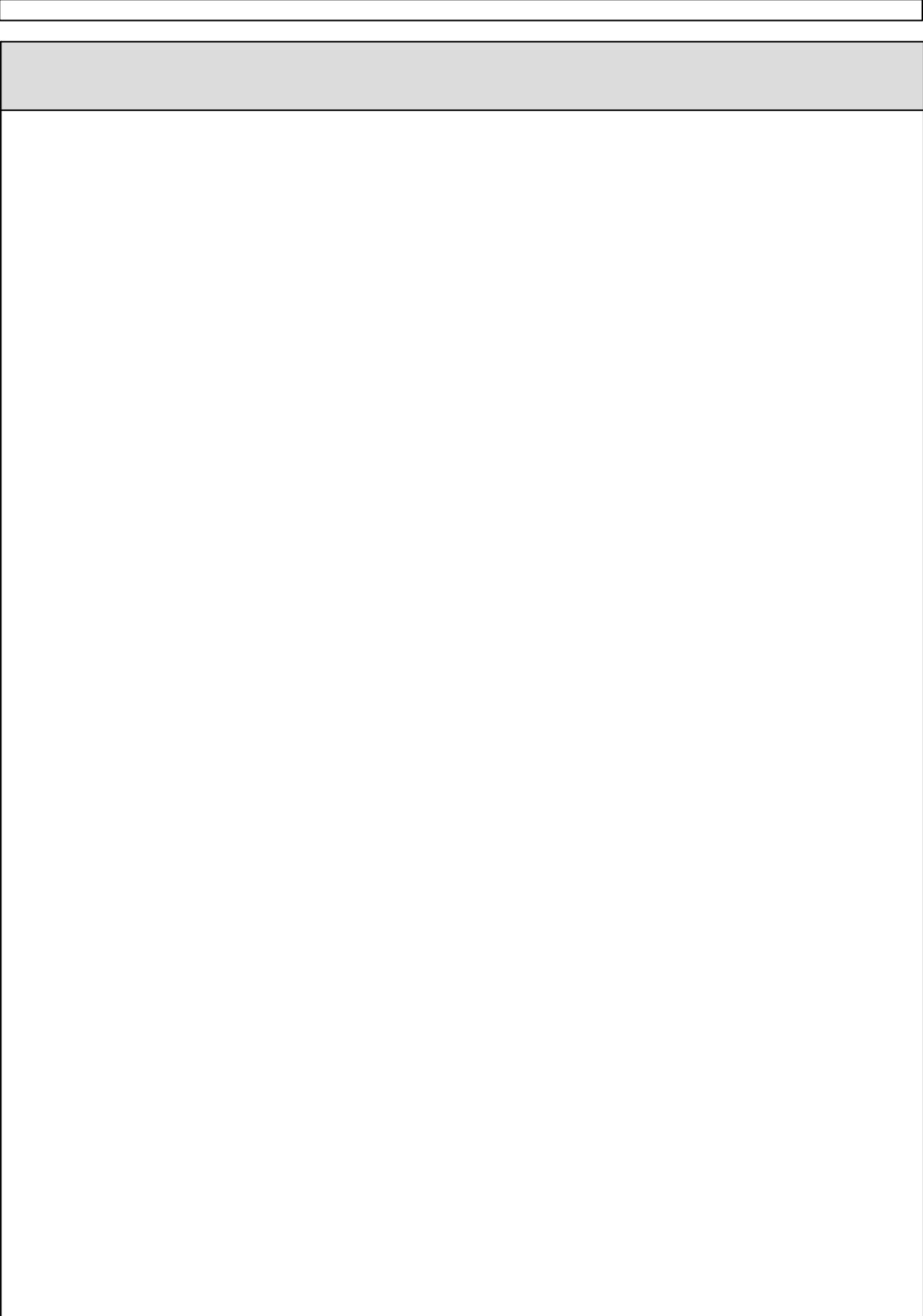
Image	Part Code	Pack	Unit	Application	Colour
	ACUN3900 Gasket Roller	1	each		MF
					SA
					KL
					HP
					SSC
					SMC
					W
					Z
					PC
					MF
					SA
					KL
					HP
					SSC
					SMC
					W
					Z
					PC
					MF
					SA
					KL
					HP
					SSC
					SMC
					W
					Z
					PC
					MF
					SA
					KL
					HP
					SSC
					SMC
					W
					Z
					PC
 <p>T-BARS ACVG66=2.5mm ACVG66=3.0mm ACVL150=4.0mm</p>  <p>Screw (Grub)</p>	MF = Mill Finish SA = Silver Anodised KL = Basic Colour HP = Special Colour SSC = Smooth Satin Chrome SMC = Smokey Chrome PC = Polished Chrome	W = White Z = Black	 		

Image	Part Code	Pack	Unit	Application	Colour
					MF
					SA
					KL
					HP
					SSC
					SMC
					W
					Z
					PC
SA					
KL					
HP					
SSC					
SMC					
W					
Z					
PC					
					SA
					KL
					HP
					SSC
					SMC
					W
					Z
					PC
SA					
KL					
HP					
SSC					
SMC					
W					
Z					
PC					
					SA
					KL
					HP
					SSC
					SMC
					W
					Z
					PC
					 <p>T-BARS ACVG65=2.5mm ACVG66=3.0mm ACVL150=4.0mm</p>  <p>Screw (Grub)</p>

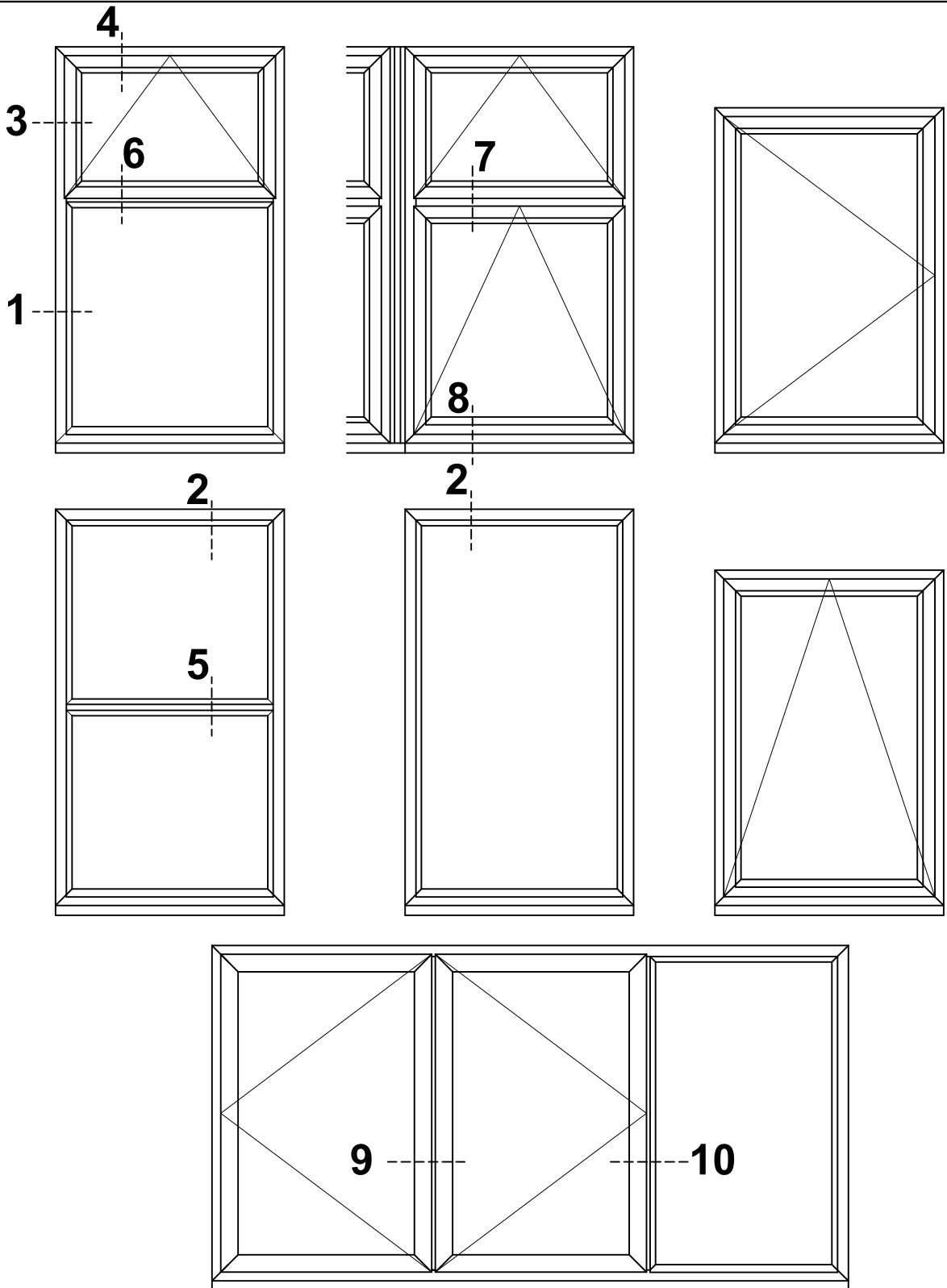
Section C

Sections

Scale Elevations

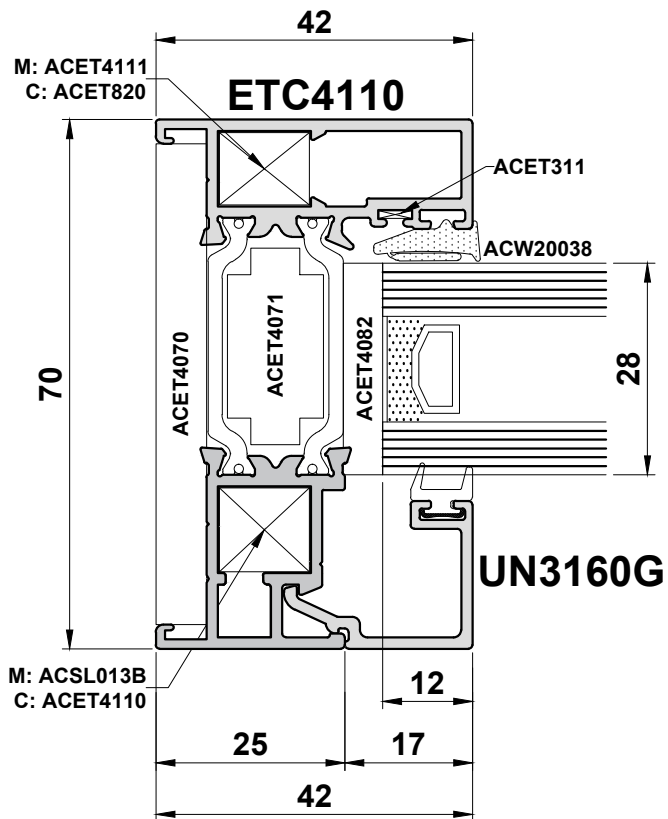
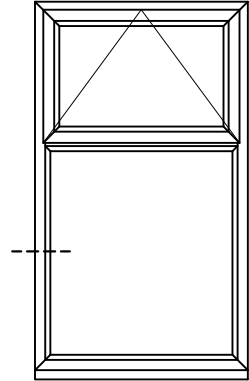


Standard Casement Detail



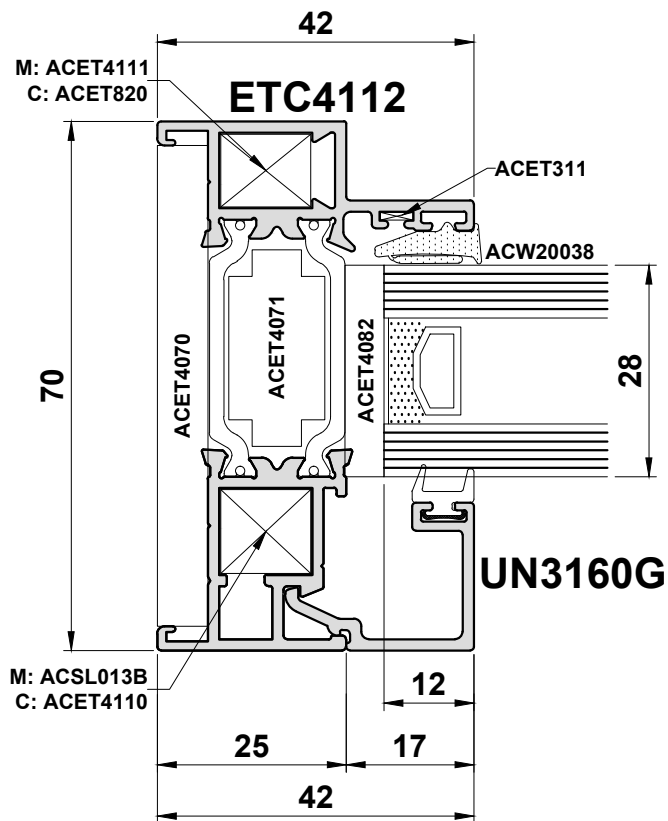
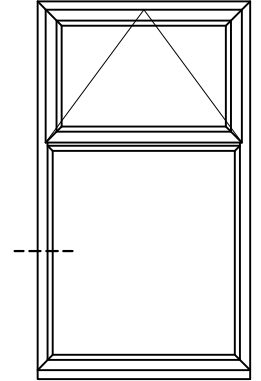
Do Not Scale From This Drawing

Detail 1A



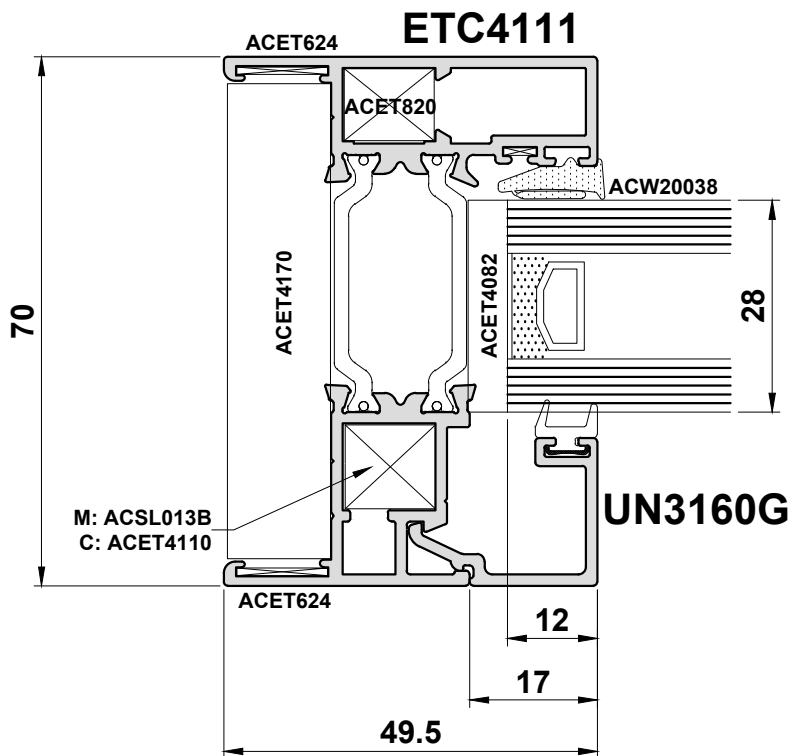
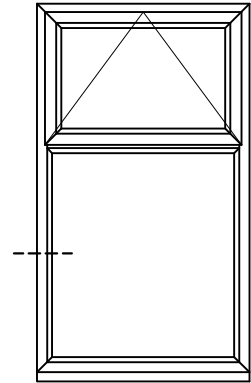
Do Not Scale From This Drawing

Detail 1B



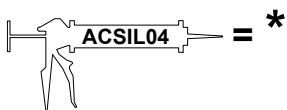
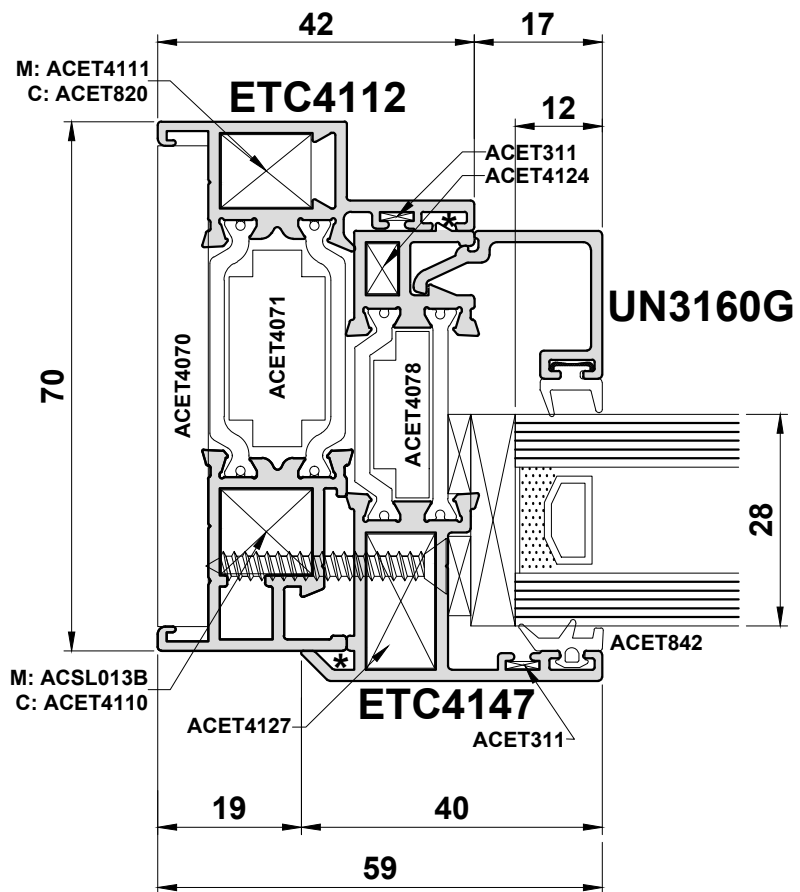
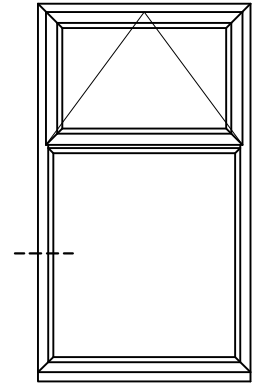
Do Not Scale From This Drawing

Detail 1C



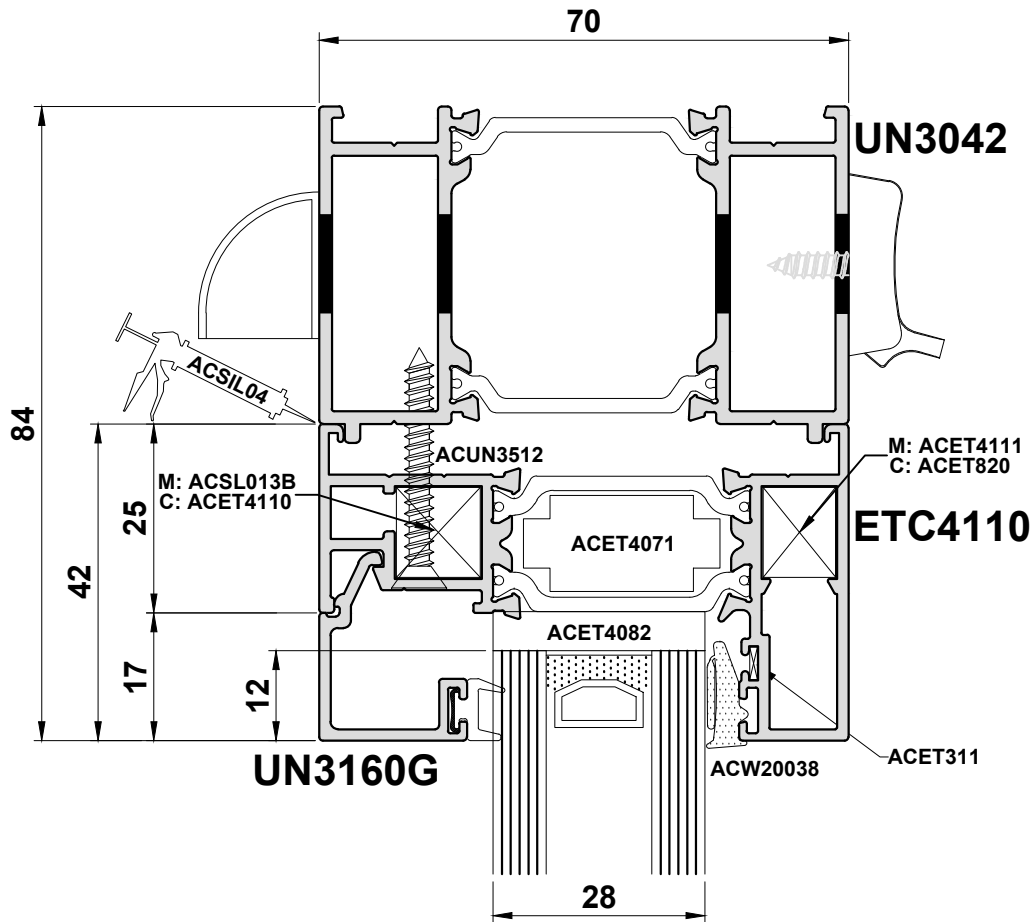
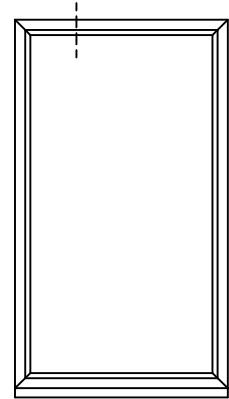
Do Not Scale From This Drawing

Detail 1D



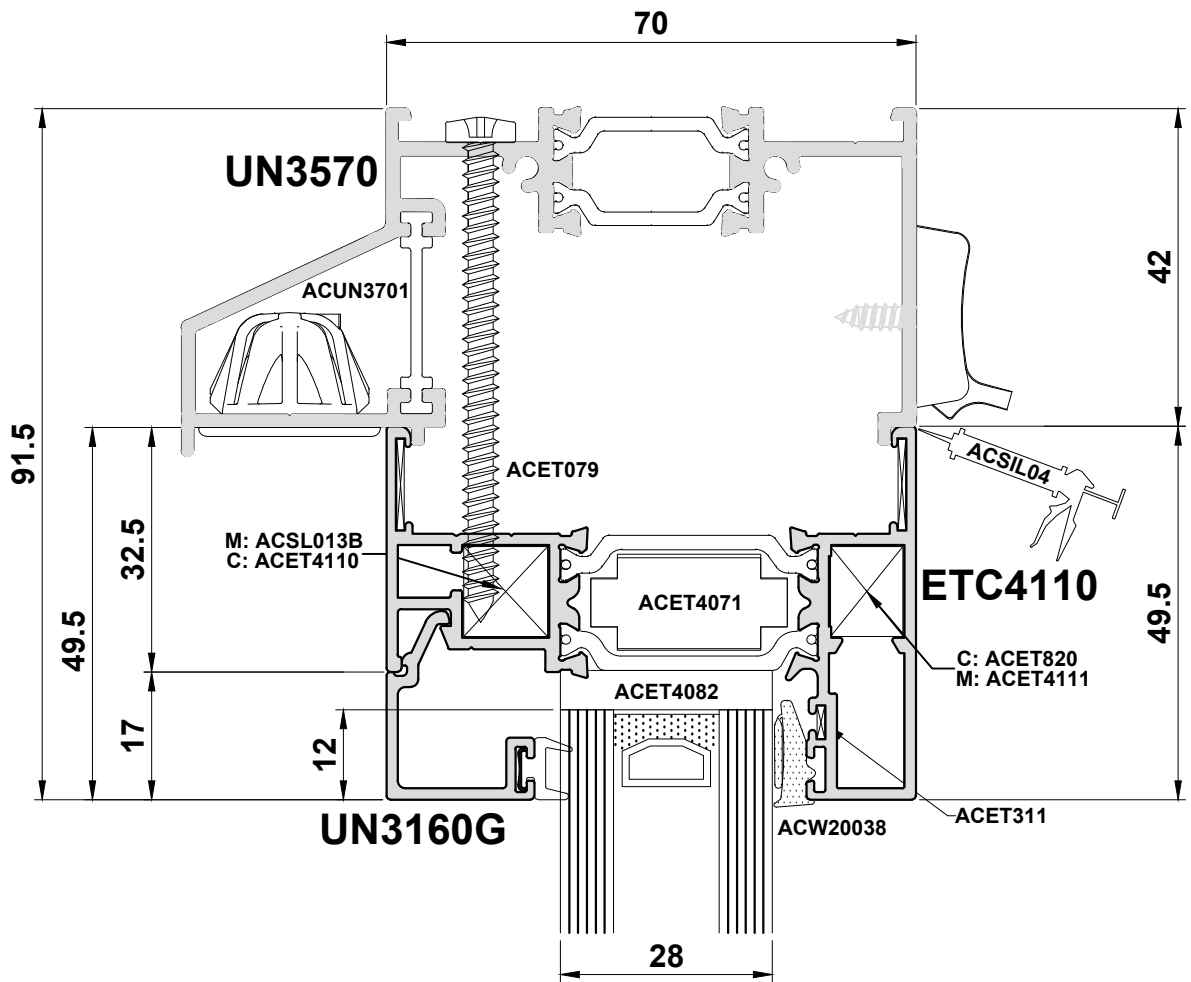
Do Not Scale From This Drawing

Detail 2A



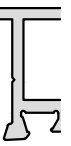
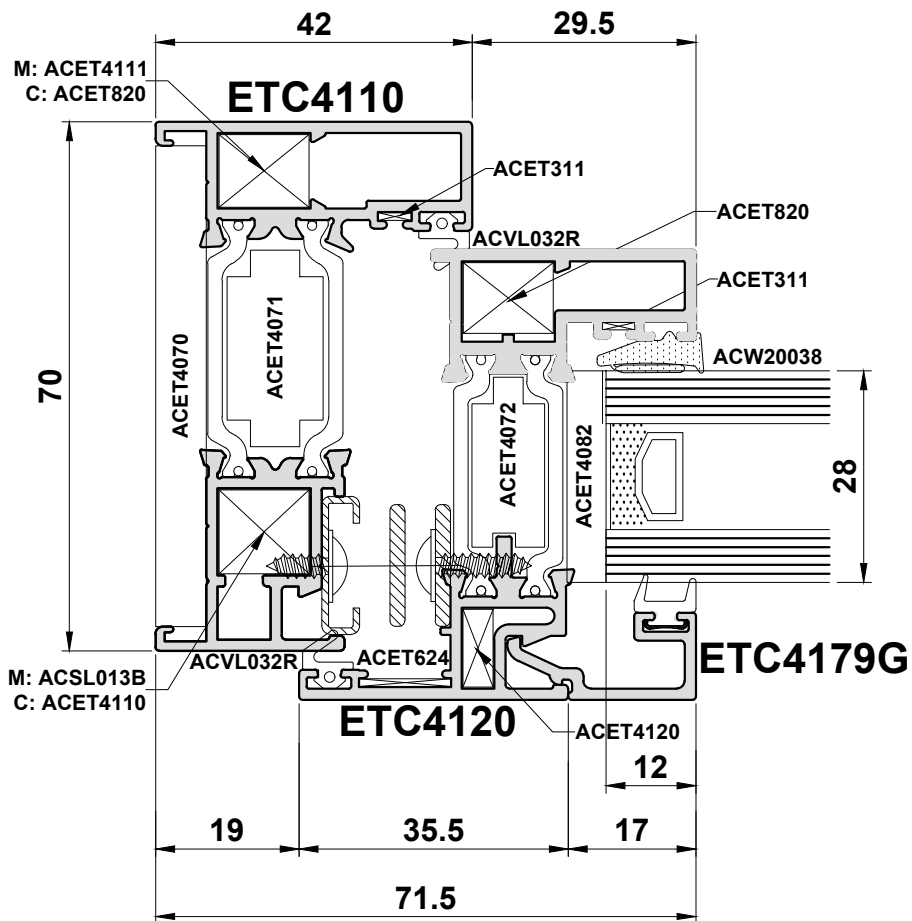
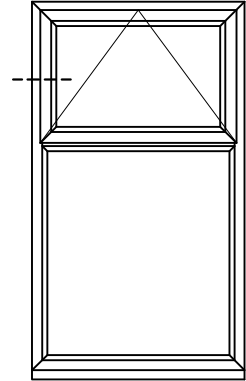
Do Not Scale From This Drawing

Detail 2B



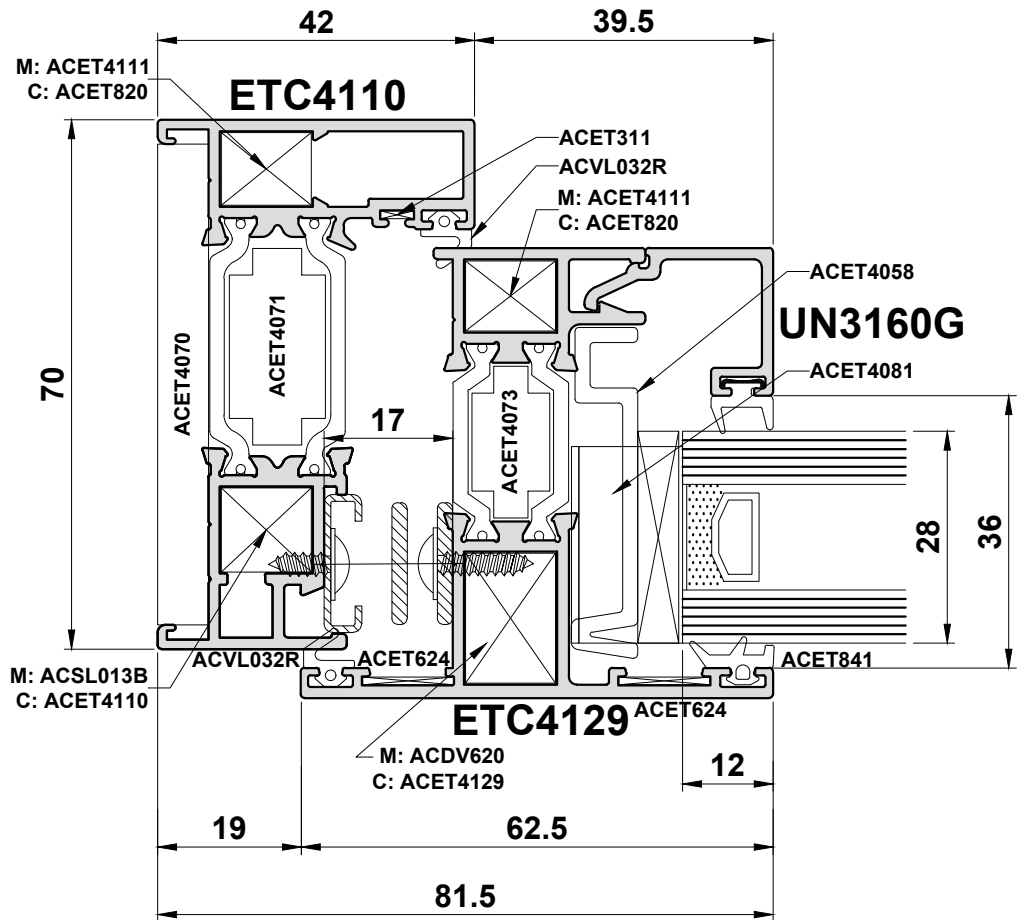
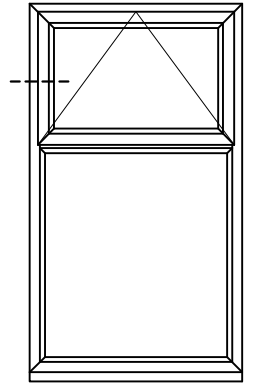
Do Not Scale From This Drawing

Detail 3A



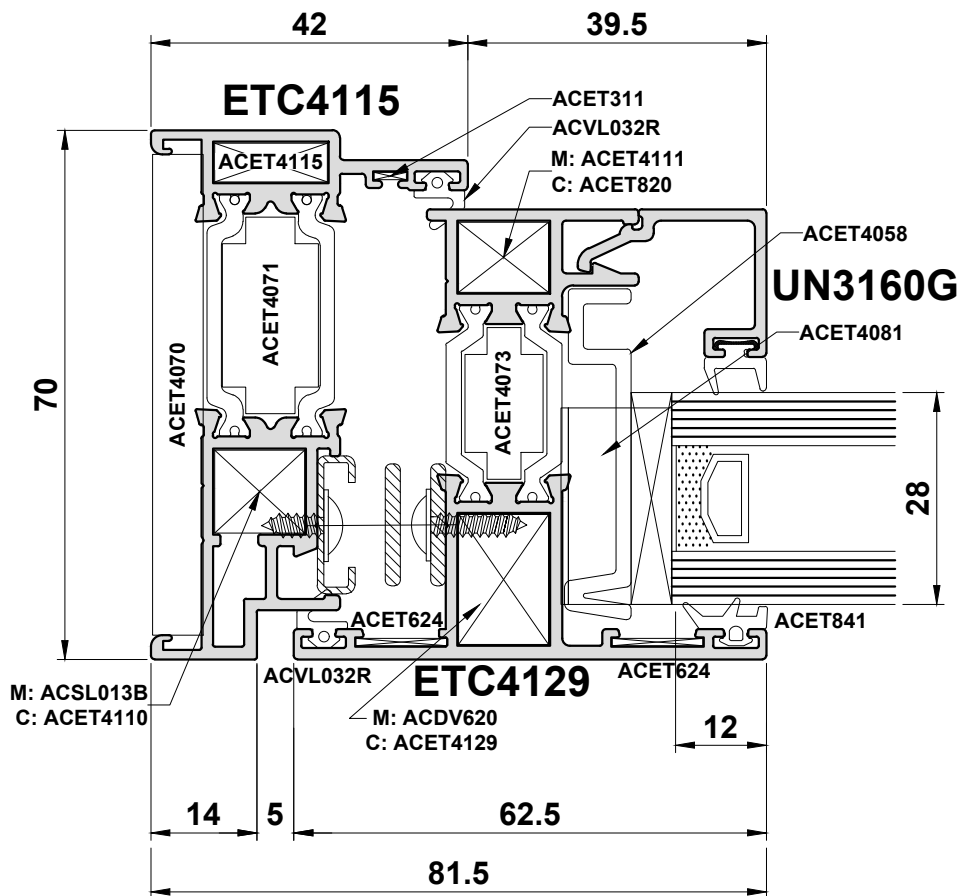
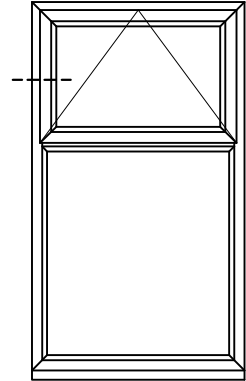
Do Not Scale From This Drawing

Detail 3B



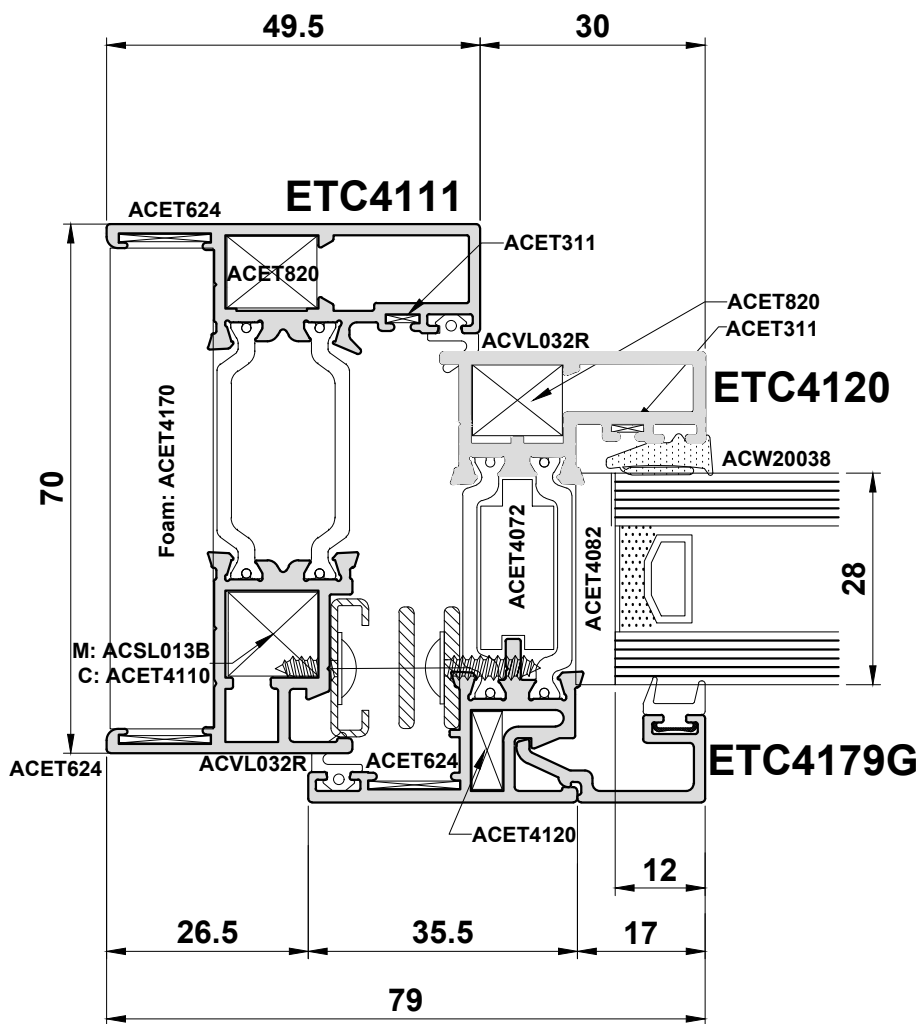
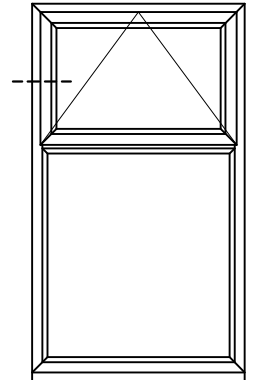
Do Not Scale From This Drawing

Detail 3C



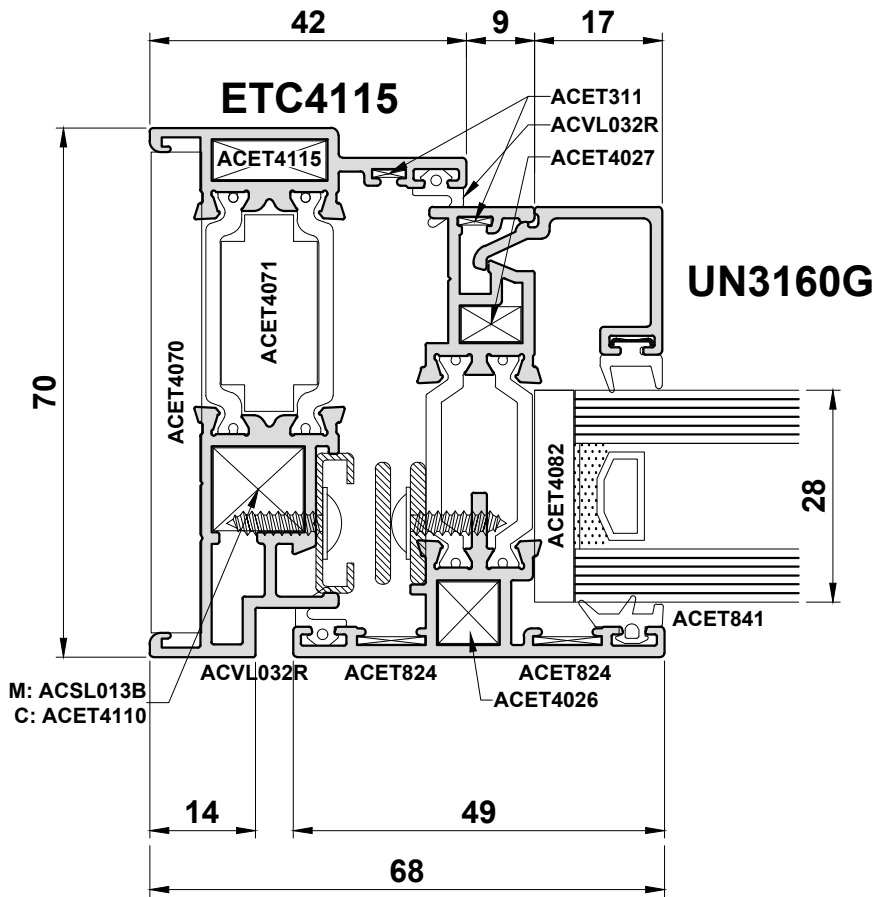
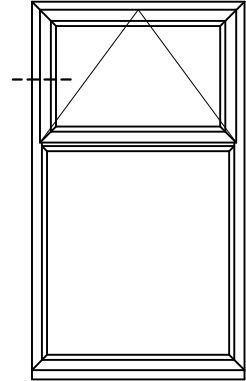
Do Not Scale From This Drawing

Detail 3D



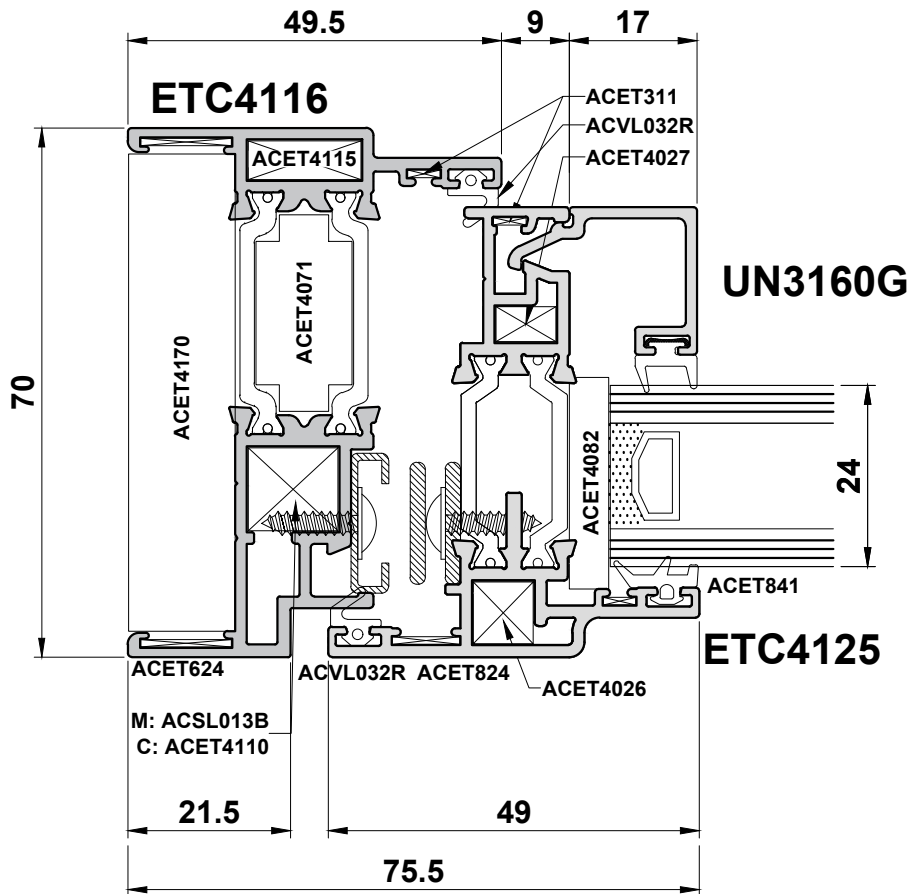
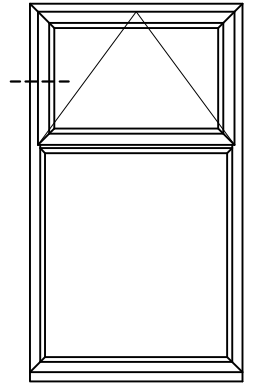
Do Not Scale From This Drawing

Detail 3E



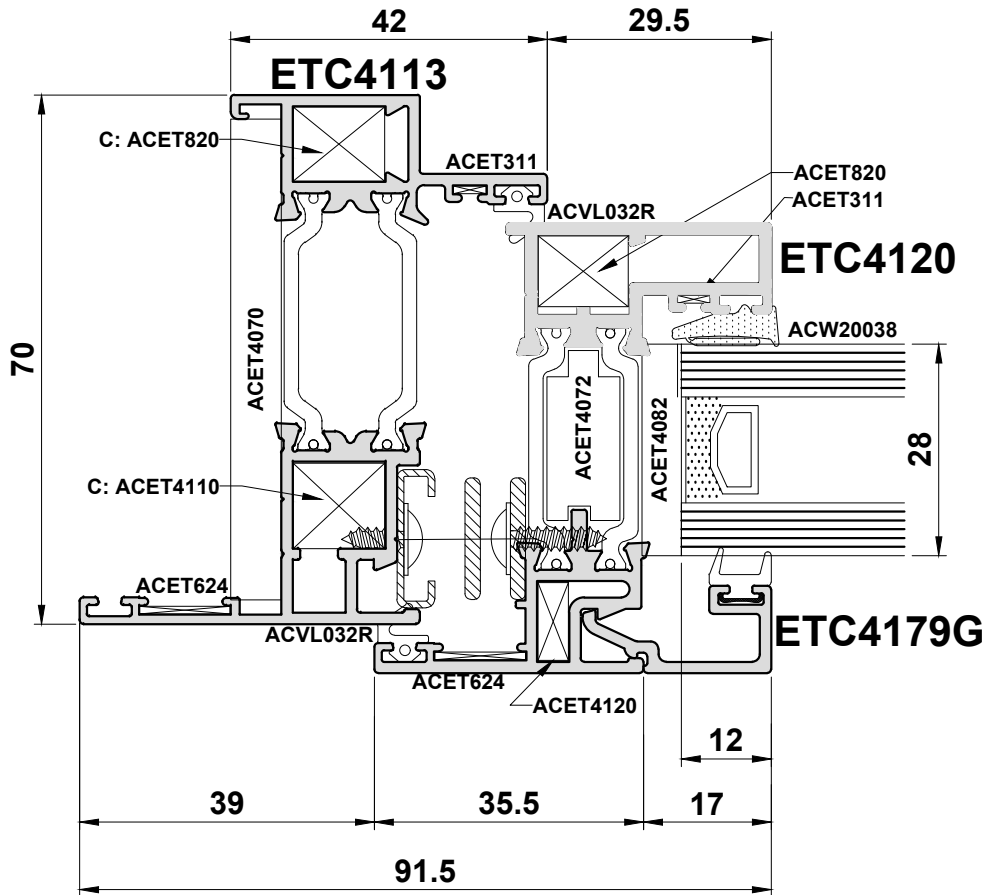
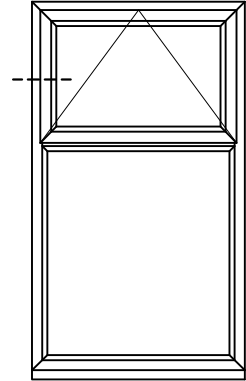
Do Not Scale From This Drawing

Detail 3F



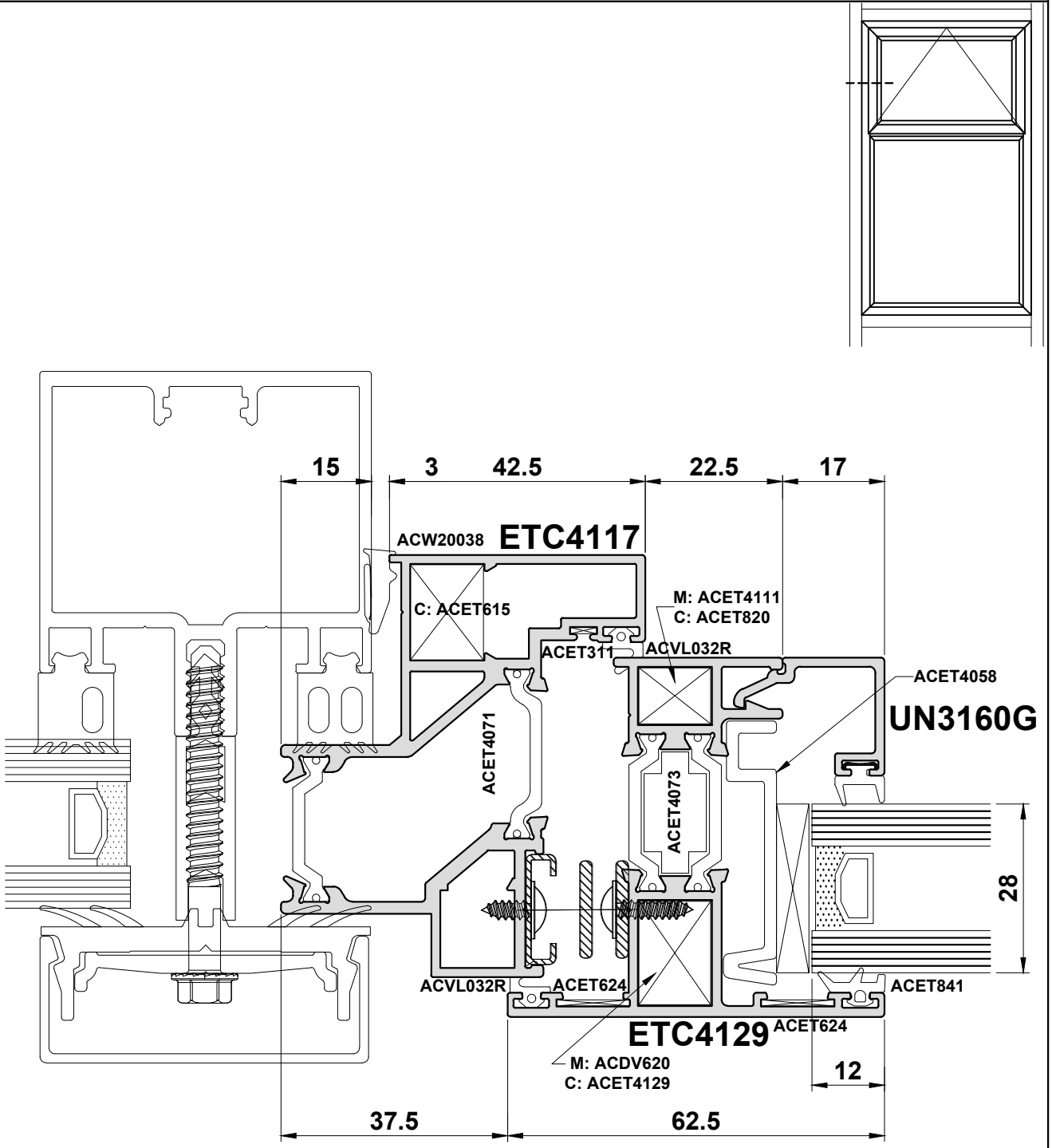
Do Not Scale From This Drawing

Detail 3G



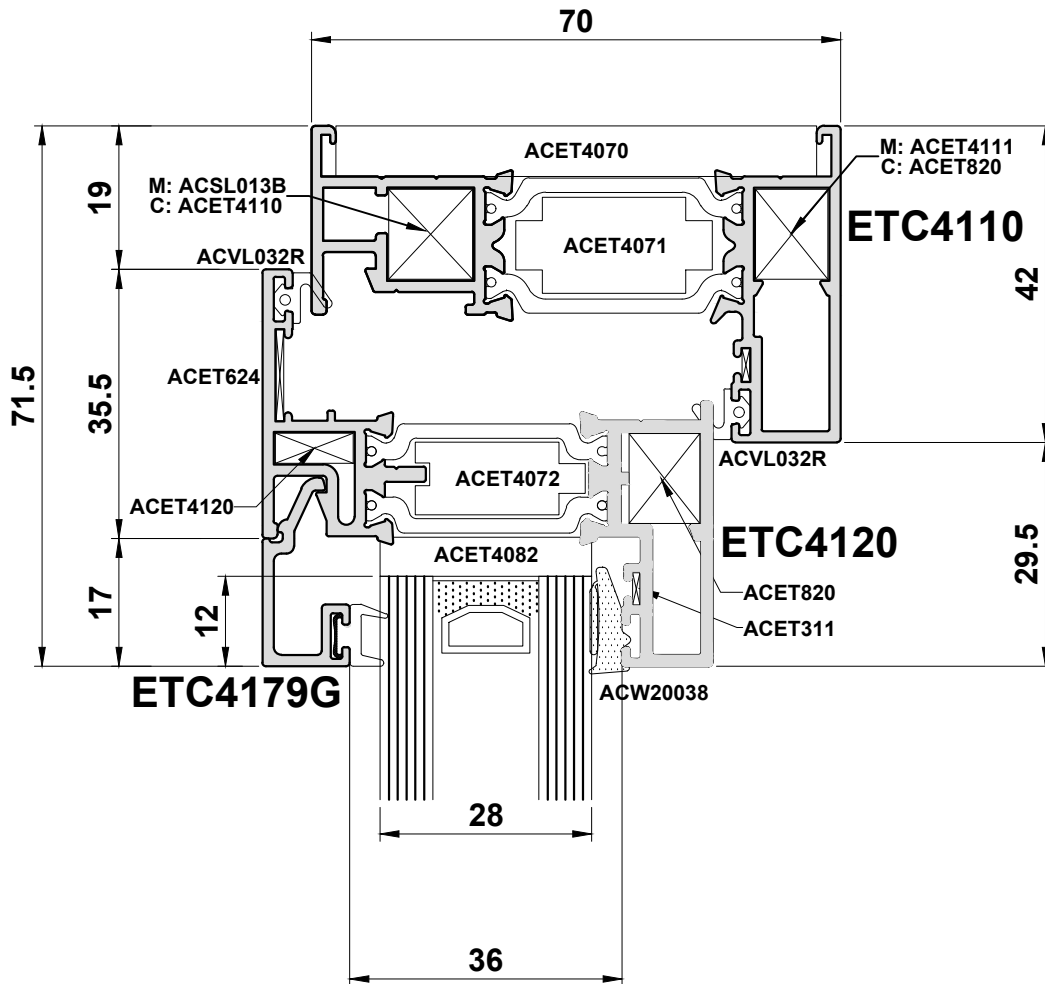
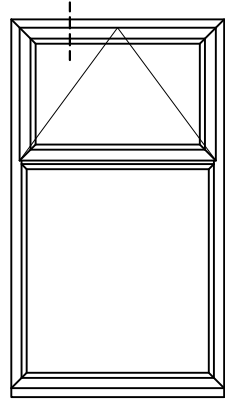
Do Not Scale From This Drawing

Detail 3H



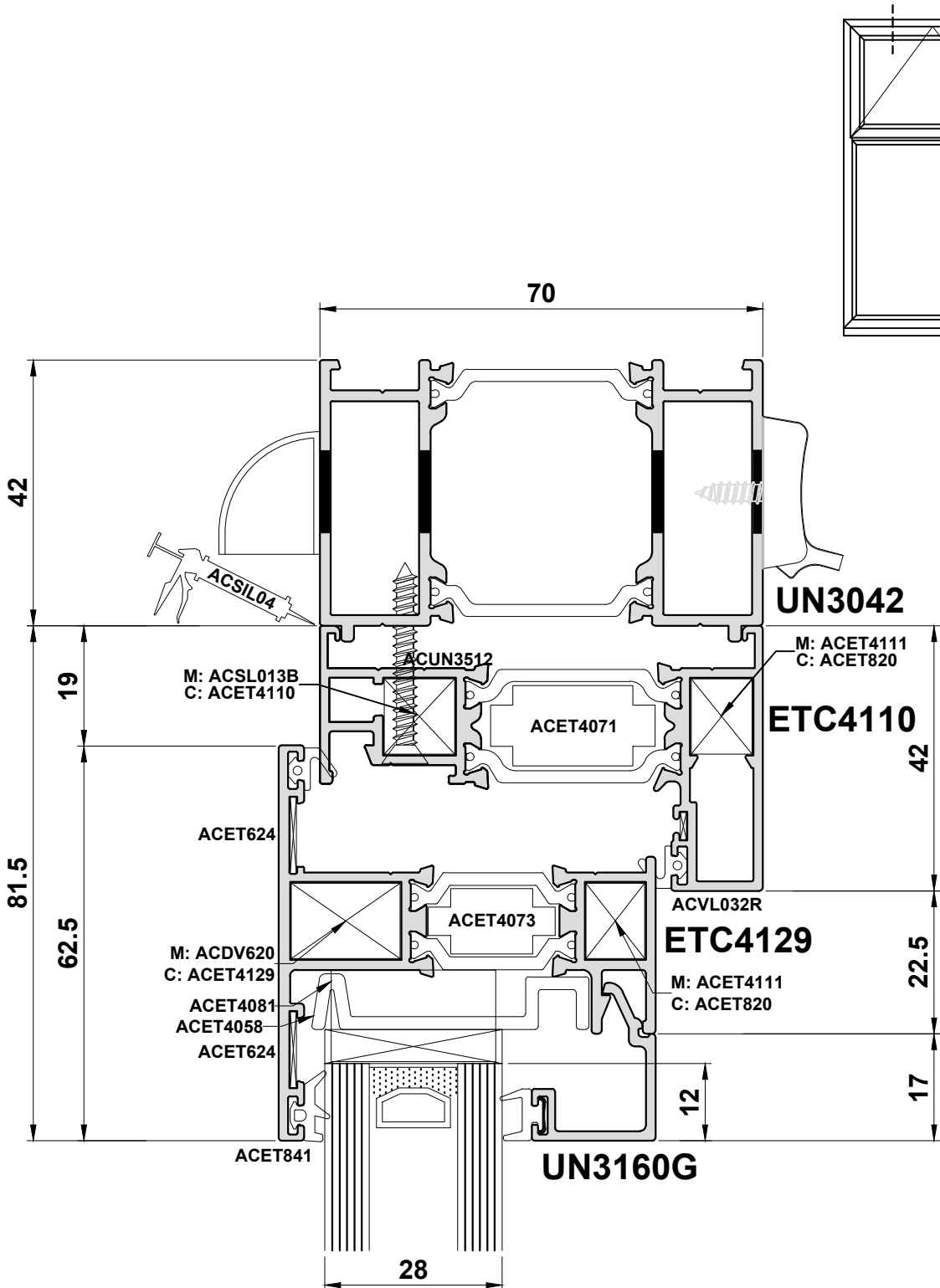
Do Not Scale From This Drawing

Detail 4A



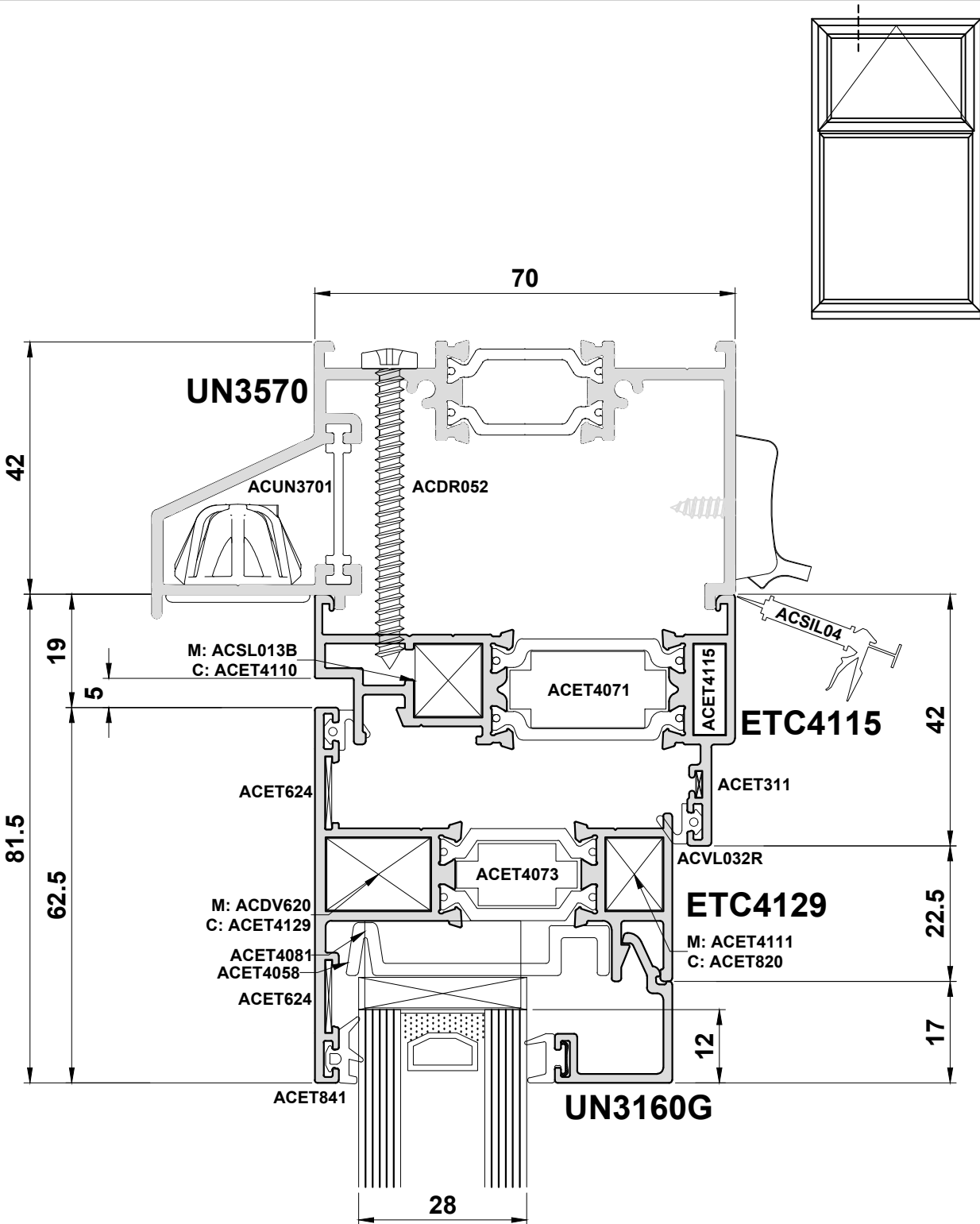
Do Not Scale From This Drawing

Detail 4B



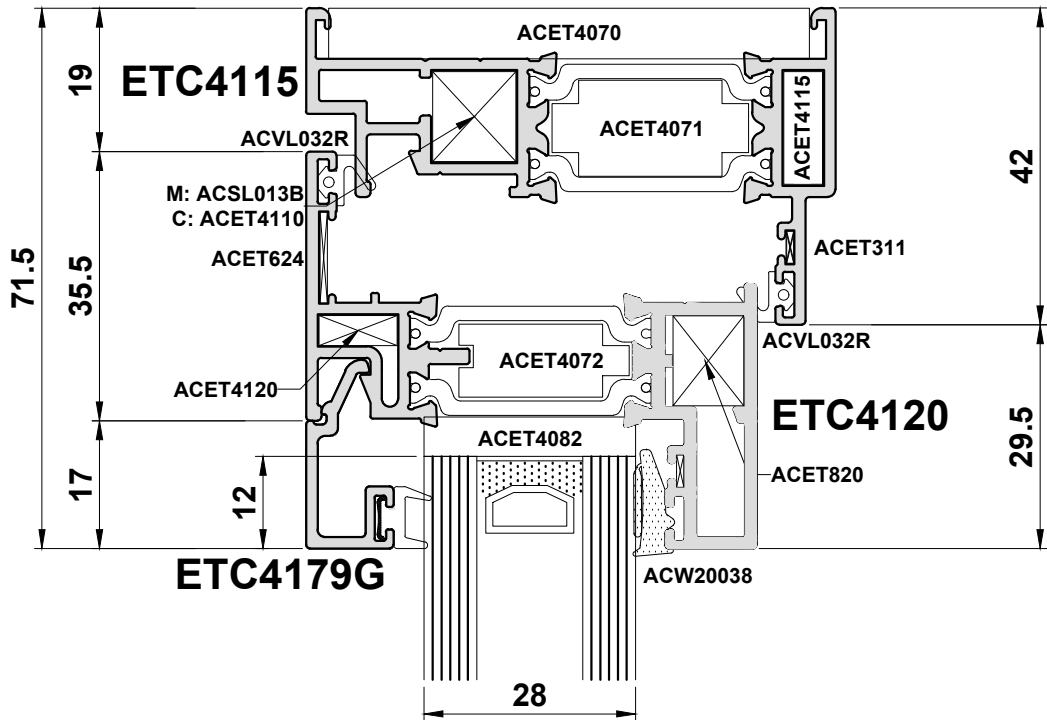
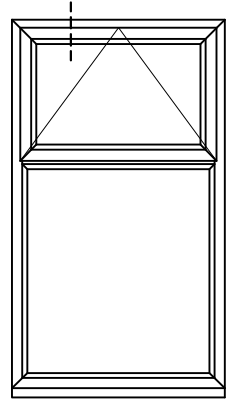
Do Not Scale From This Drawing

Detail 4C



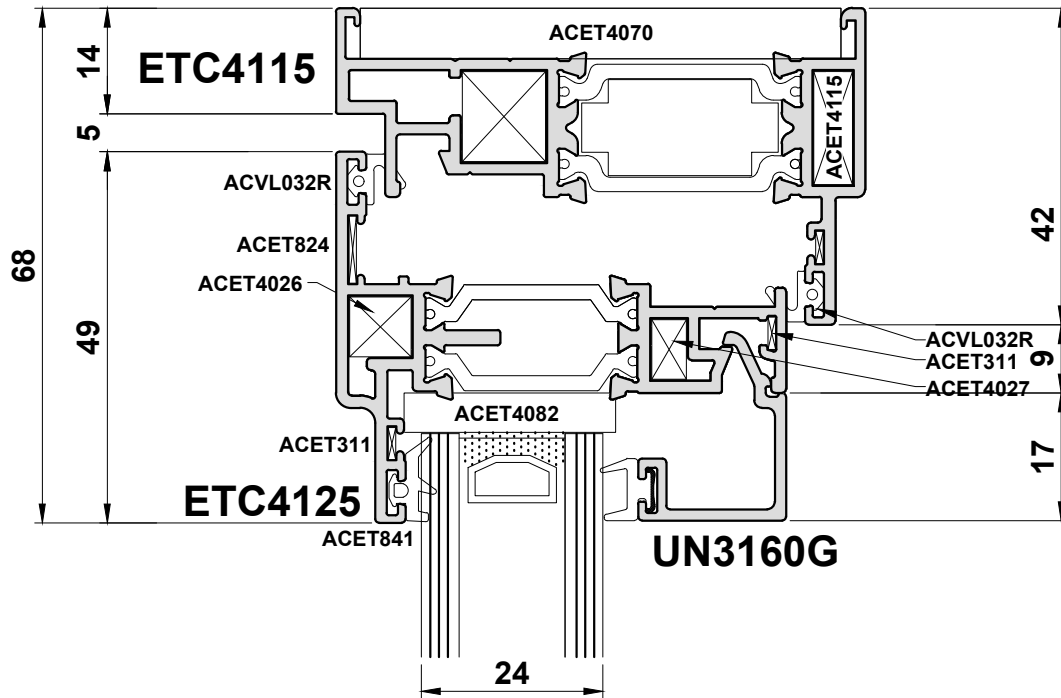
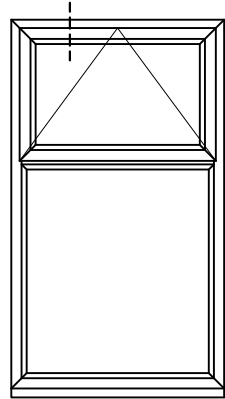
Do Not Scale From This Drawing

Detail 4D



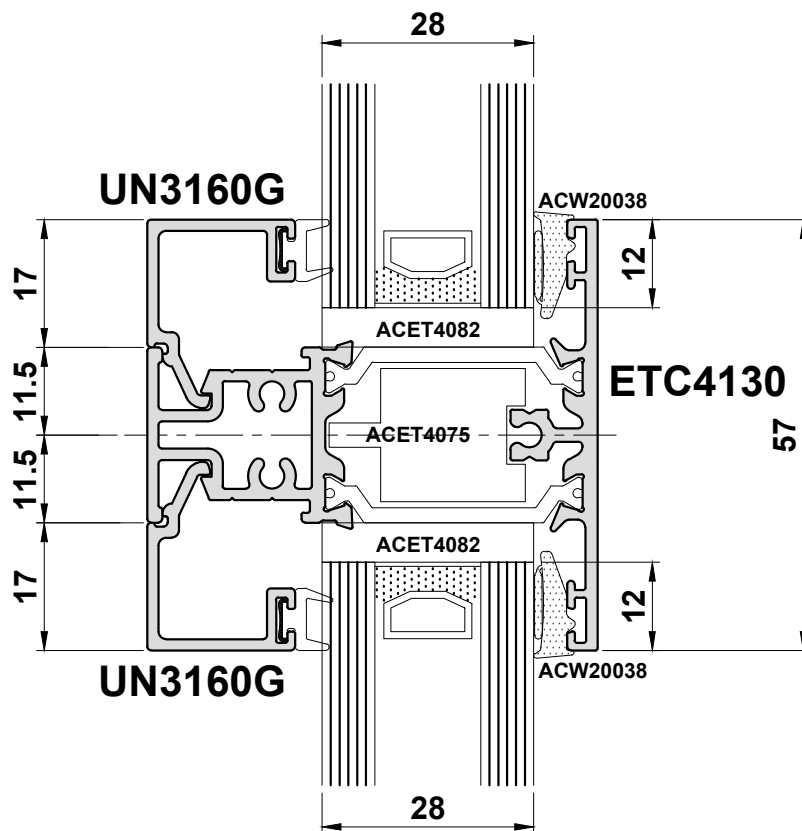
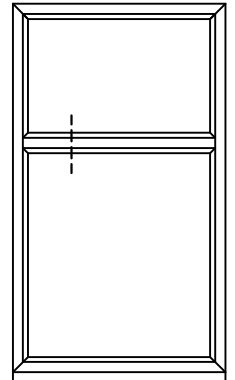
Do Not Scale From This Drawing

Detail 4E



Do Not Scale From This Drawing

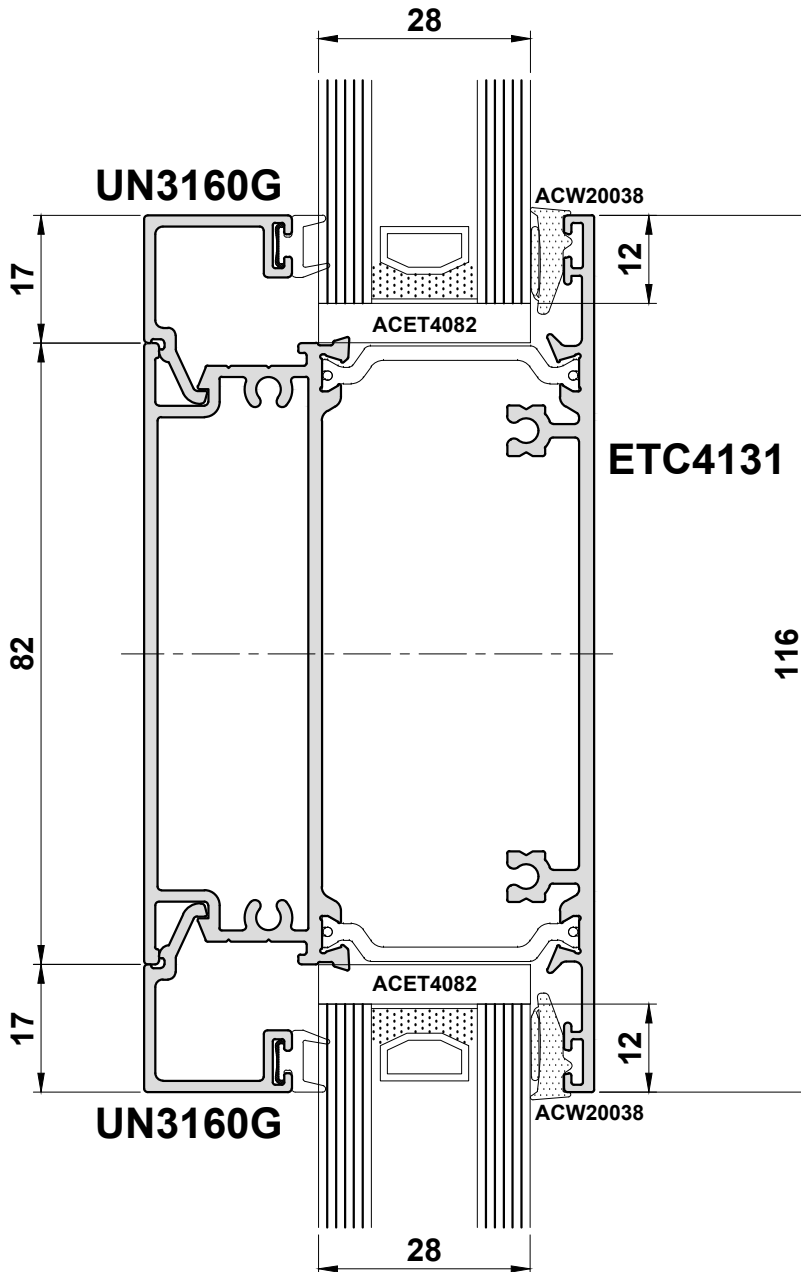
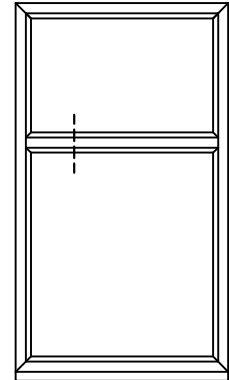
Detail 5A



Note: Transoms will drain through the joint to the outerframe.

Do Not Scale From This Drawing

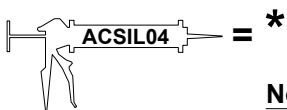
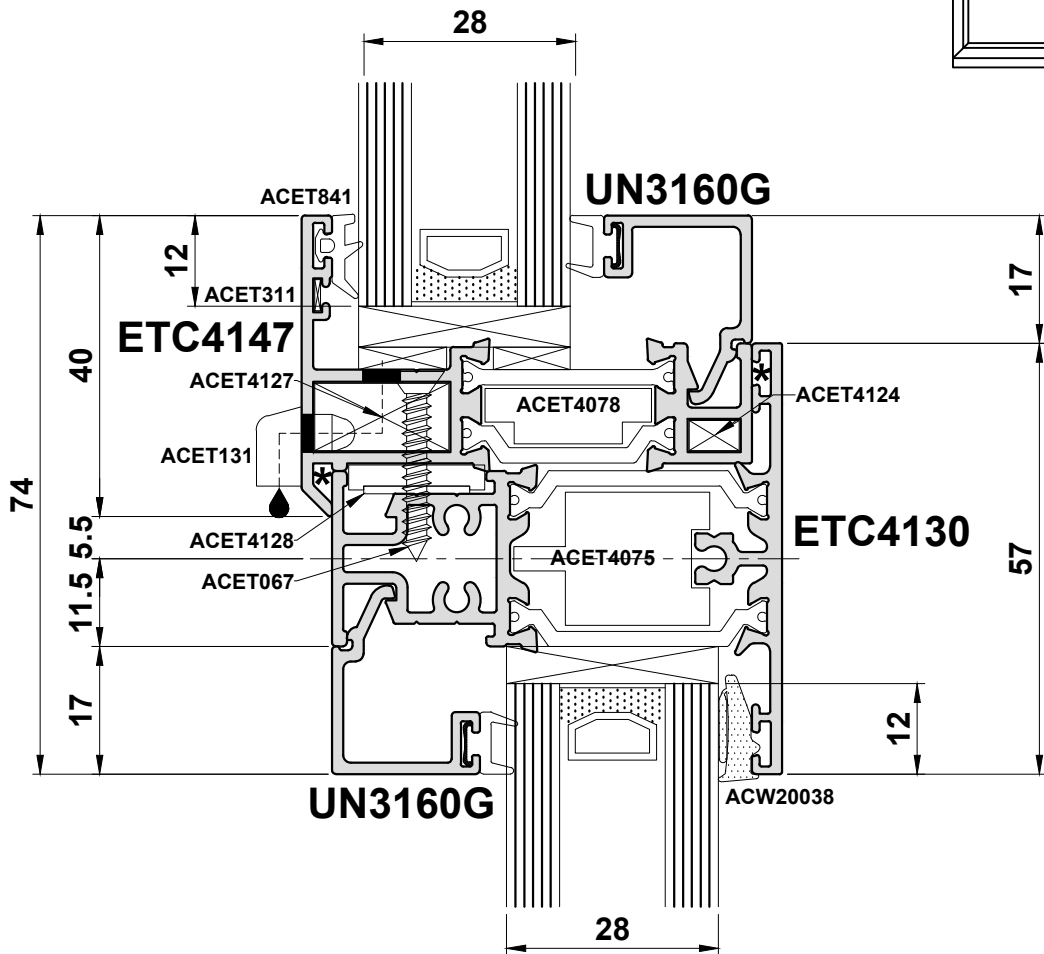
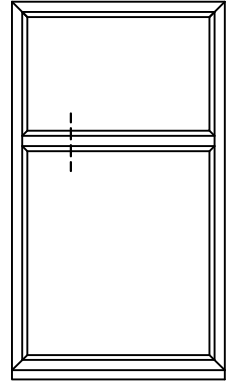
Detail 5B



Note: Transoms will drain through the join to the outerframe.

Do Not Scale From This Drawing

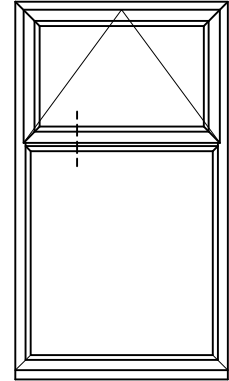
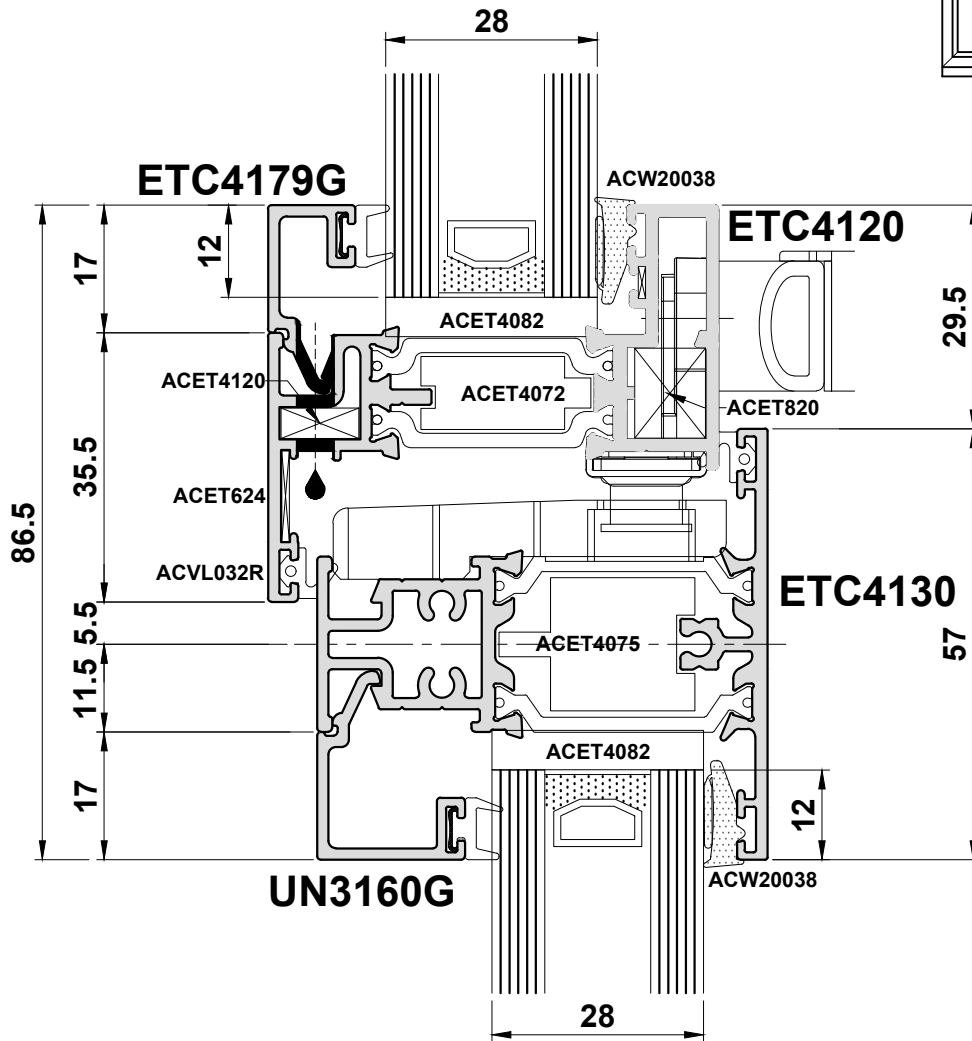
Detail 5C



Note: Transoms will drain through the joint to the outerframe.

Do Not Scale From This Drawing

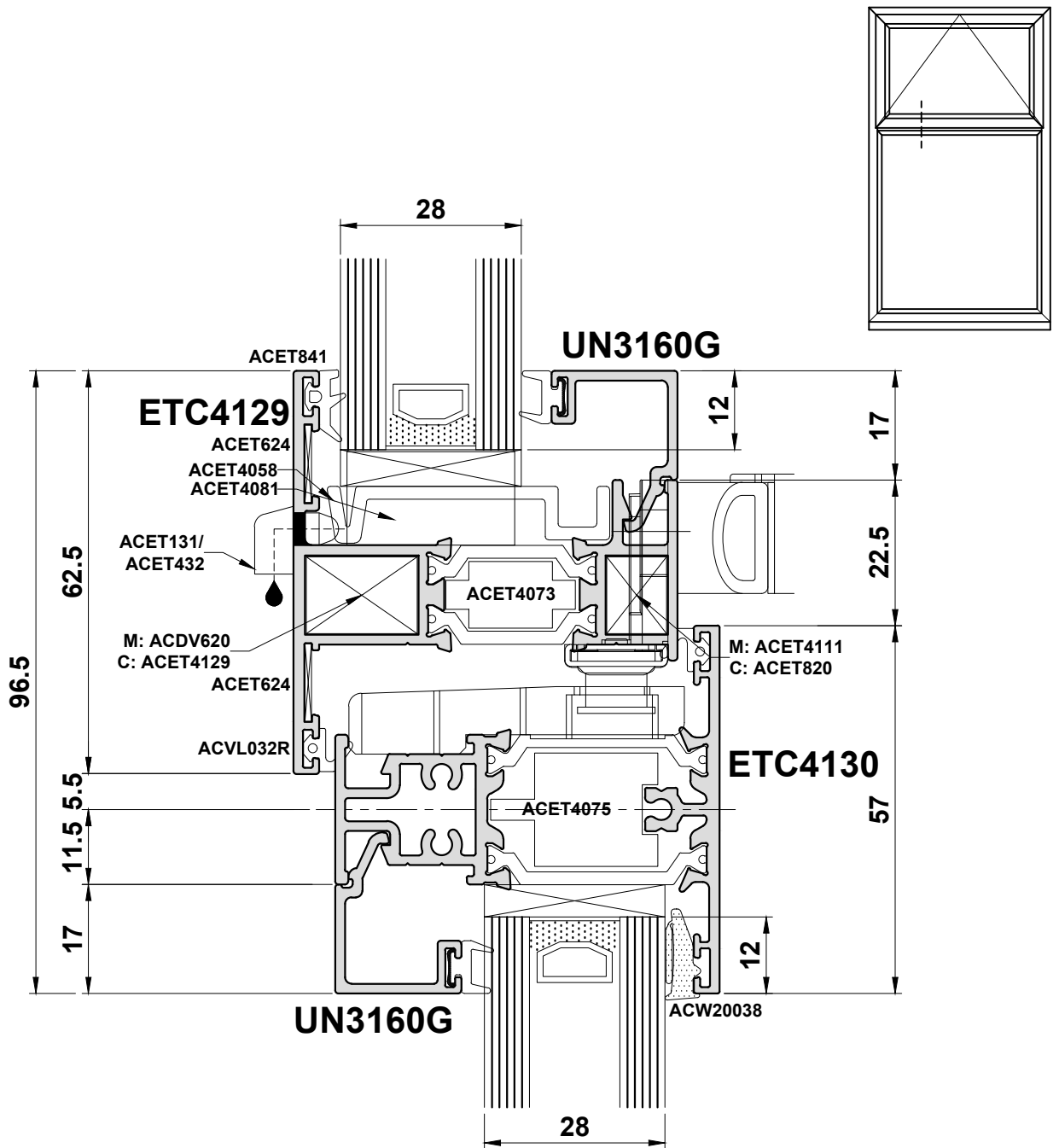
Detail 6A



Note: Transoms will drain through the joint to the outerframe.

Do Not Scale From This Drawing

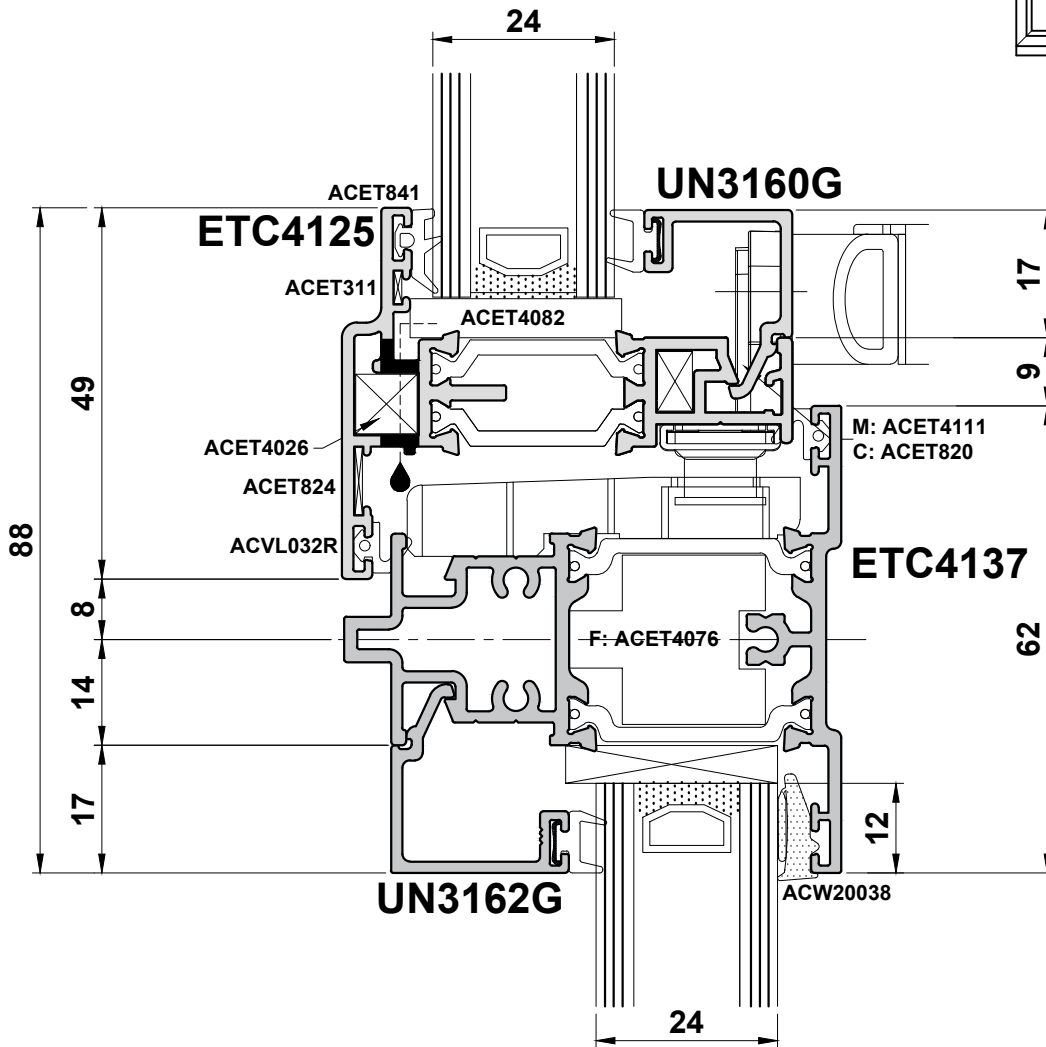
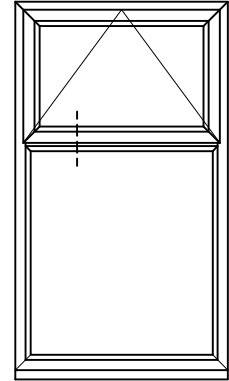
Detail 6B



Note: Transoms will drain through the joint to the outerframe.

Do Not Scale From This Drawing

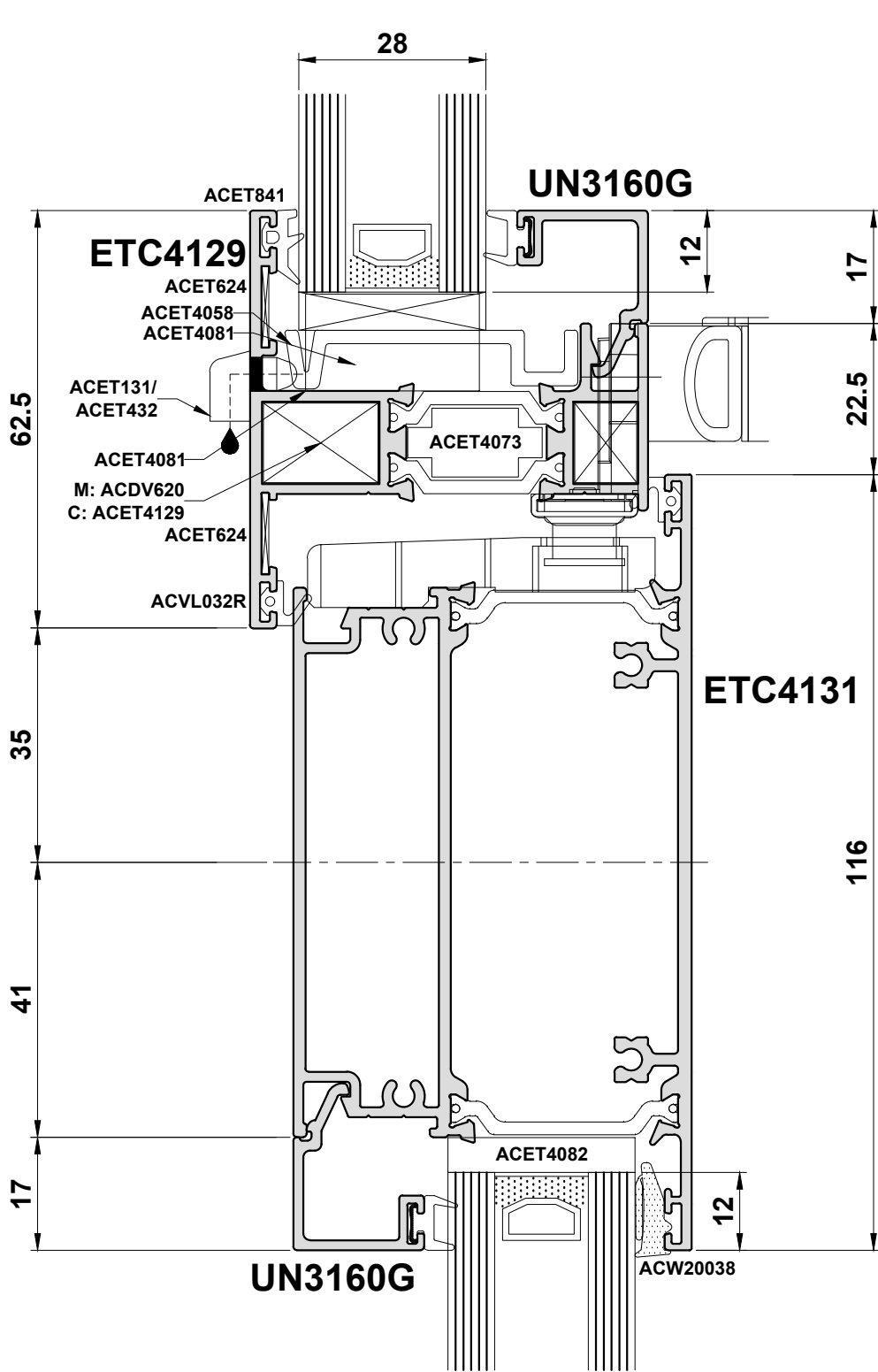
Detail 6C



Note: Transoms will drain through the join to the outerframe.

Do Not Scale From This Drawing

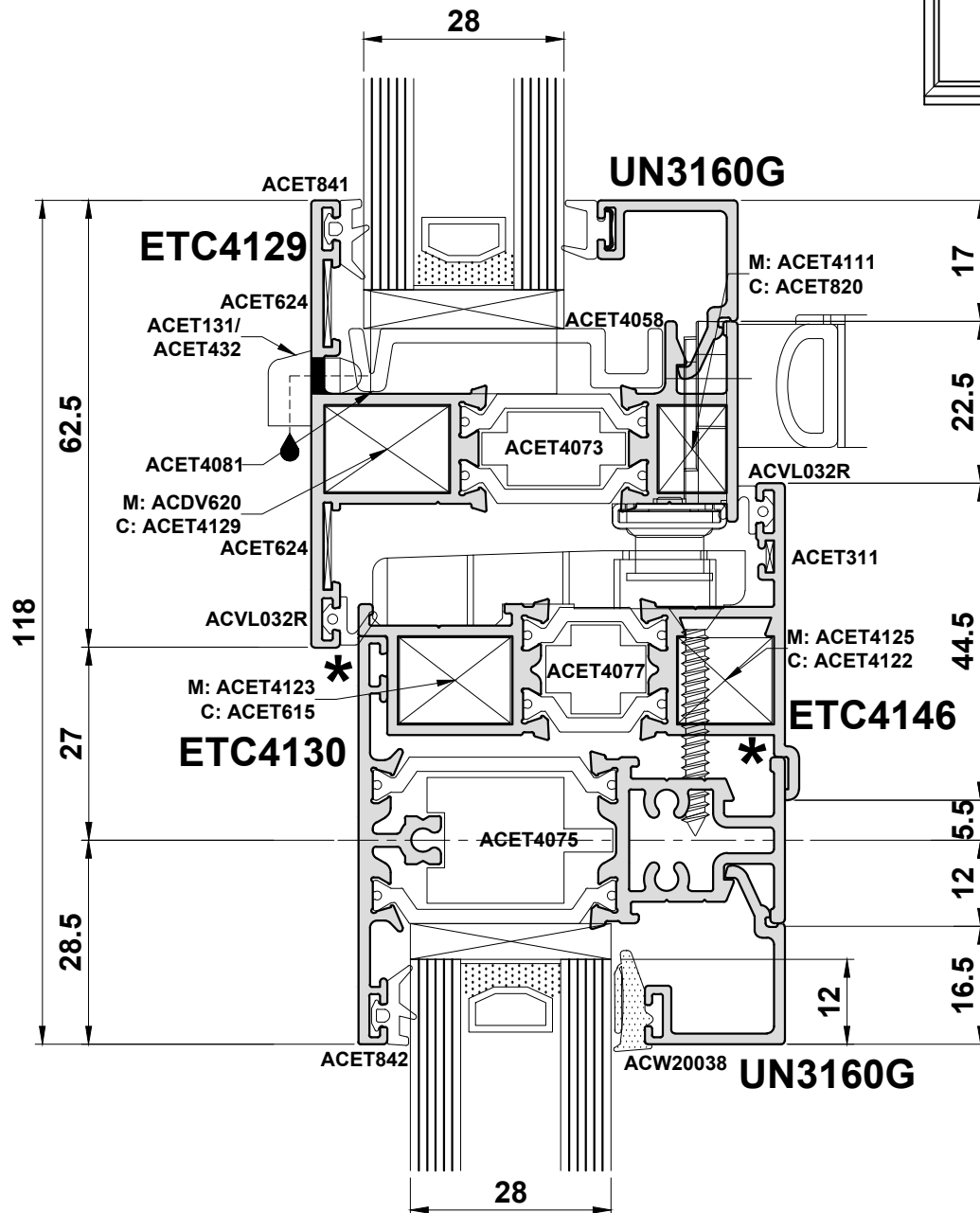
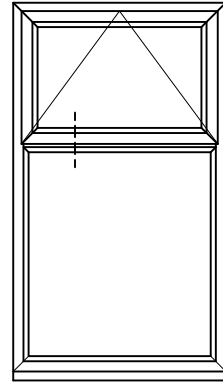
Detail 6D



Note: Transoms will drain through the join to the outerframe.

Do Not Scale From This Drawing

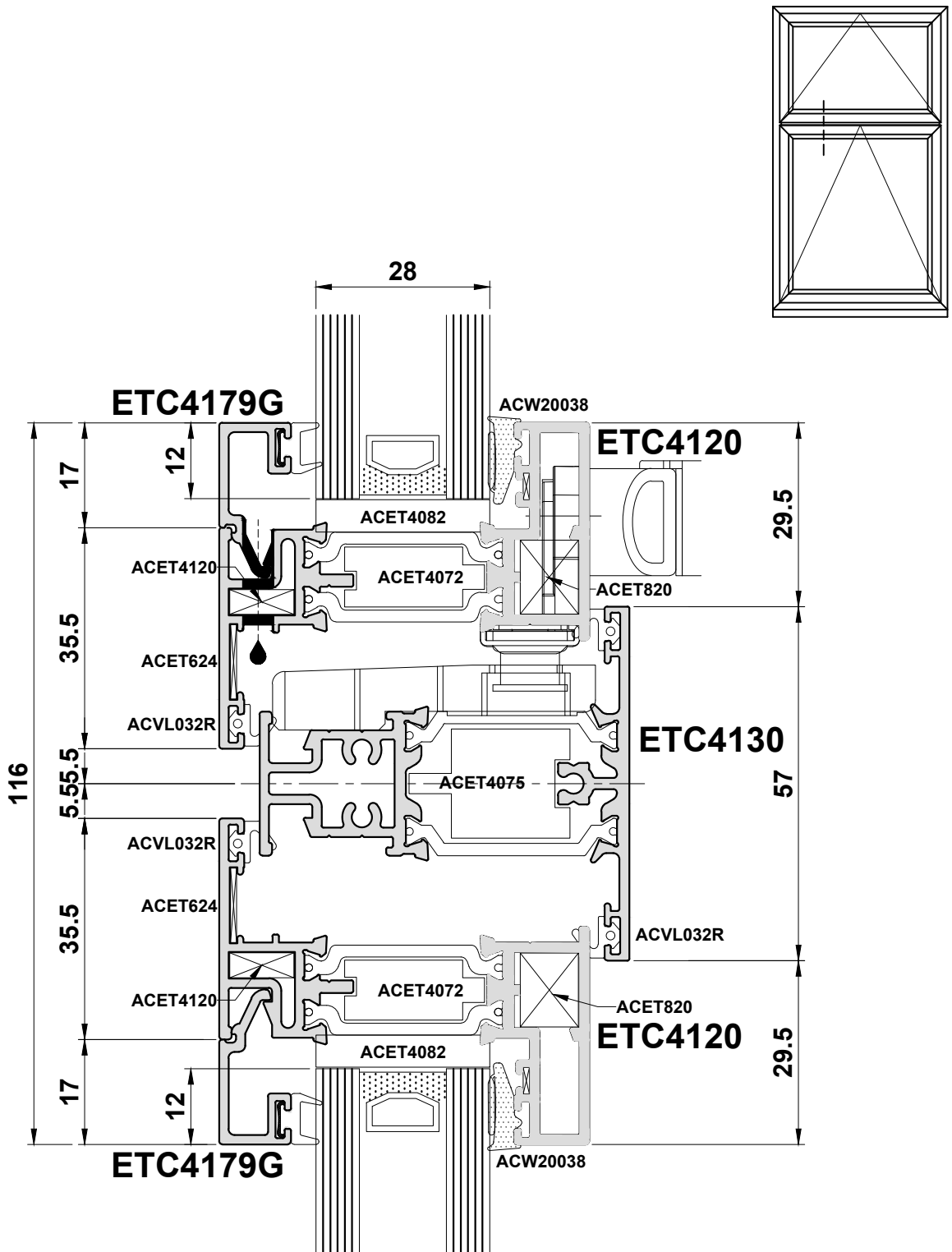
Detail 6E



Note: Transoms will drain through the join to the outerframe.

Do Not Scale From This Drawing

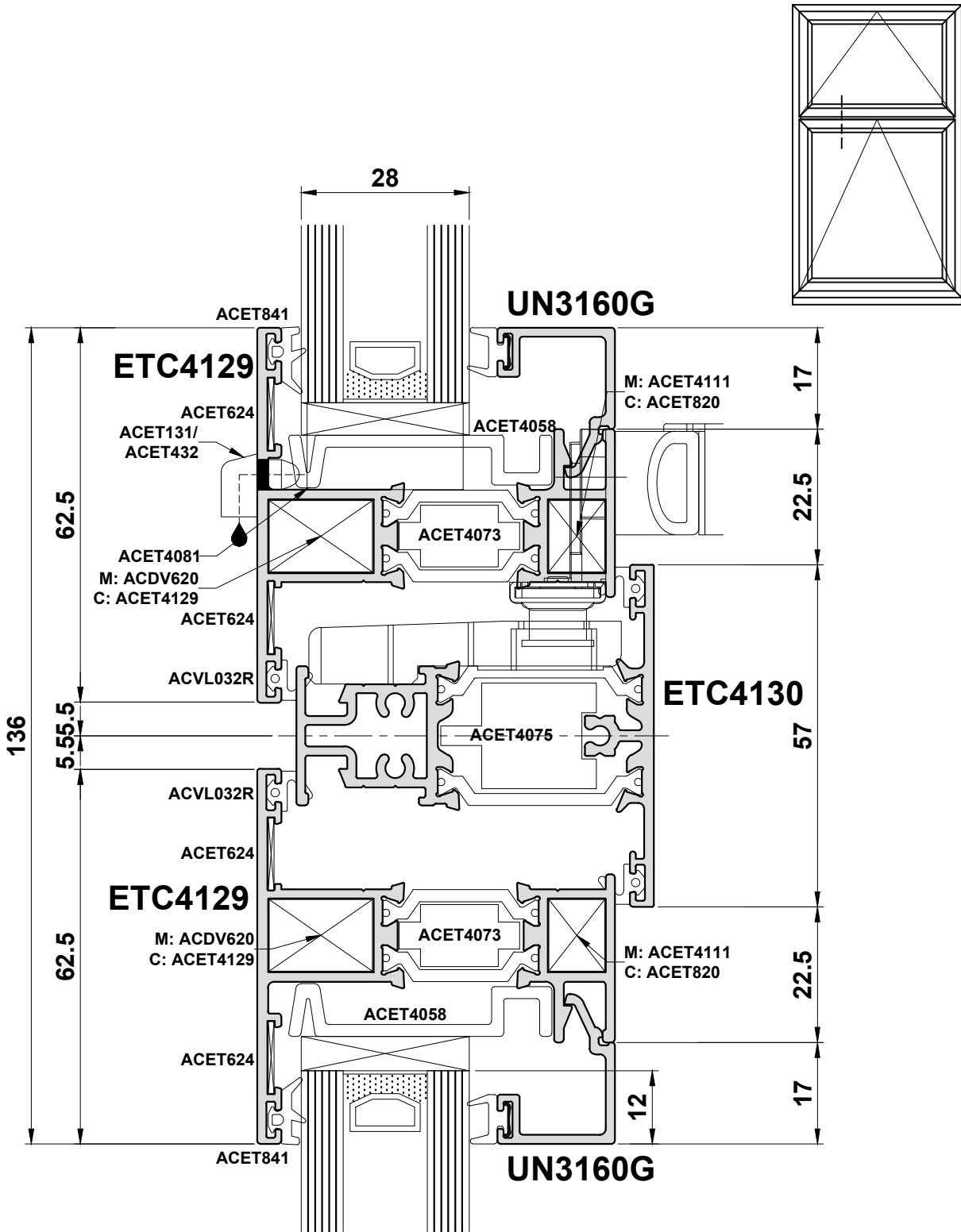
Detail 7A



Note: Transoms will drain through the joint to the outerframe.

Do Not Scale From This Drawing

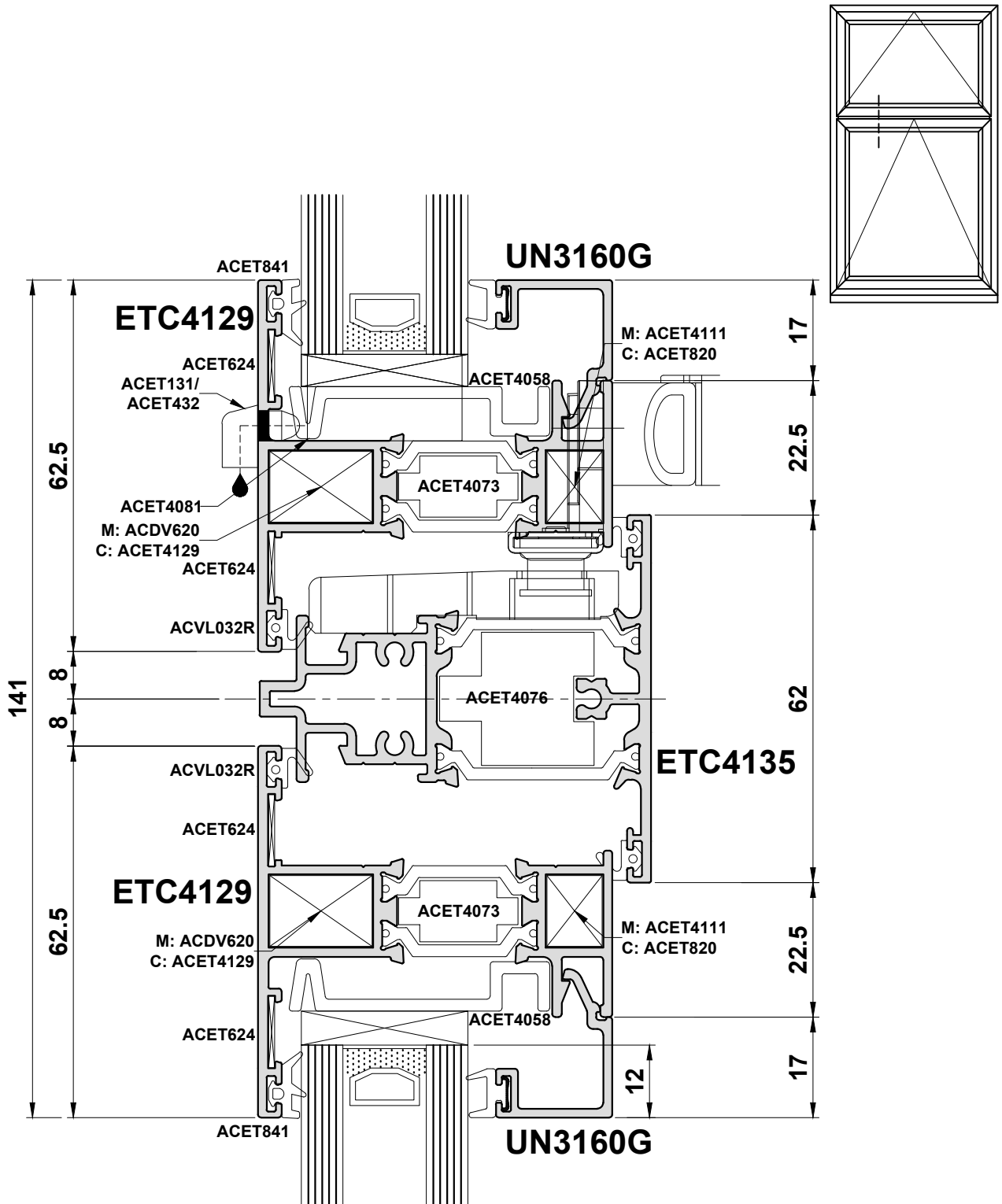
Detail 7B



Note: Transoms will drain through the join to the outerframe.

Do Not Scale From This Drawing

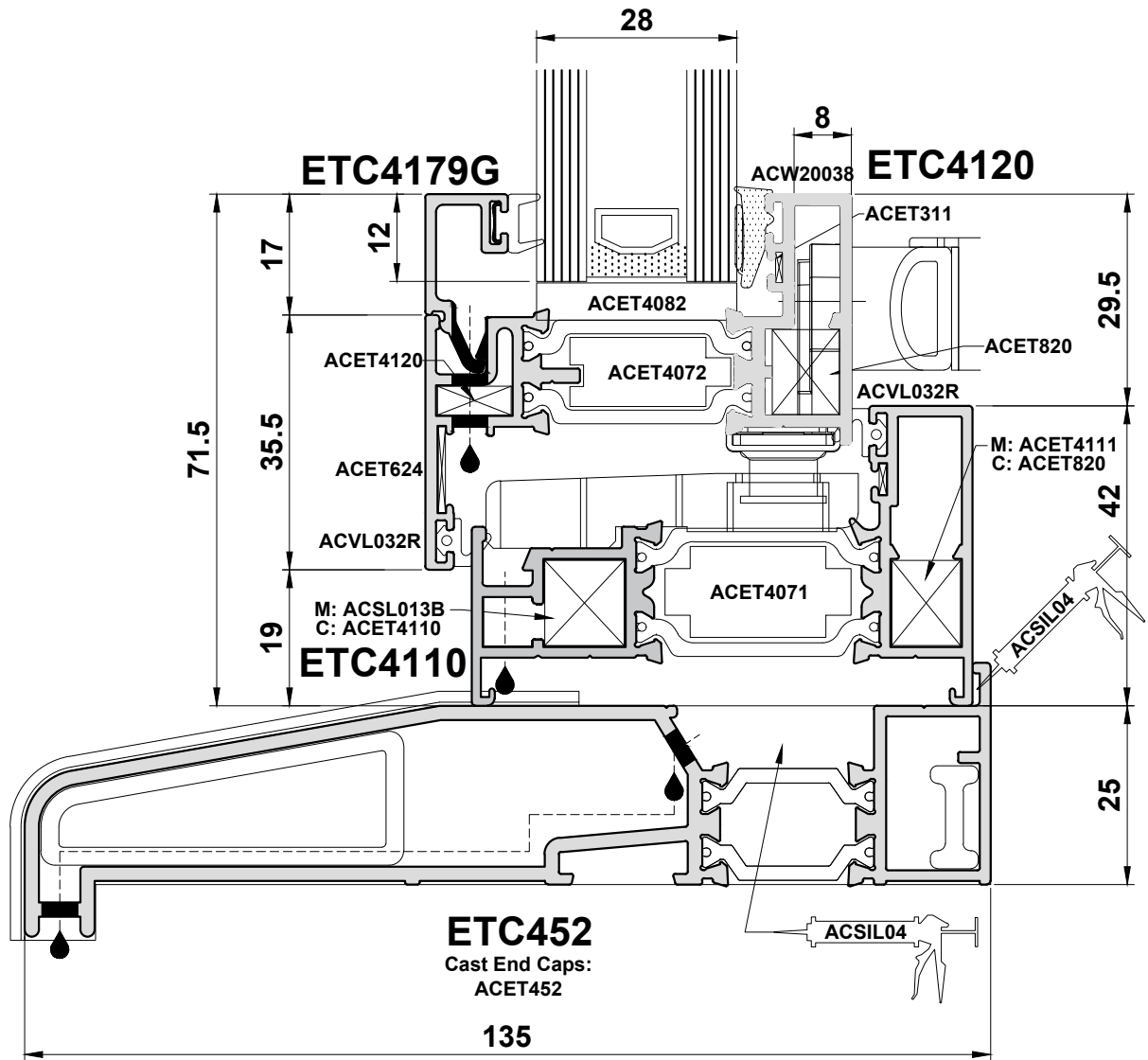
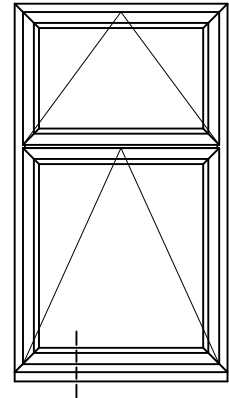
Detail 7C



Note: Transoms will drain through the join to the outerframe.

Do Not Scale From This Drawing

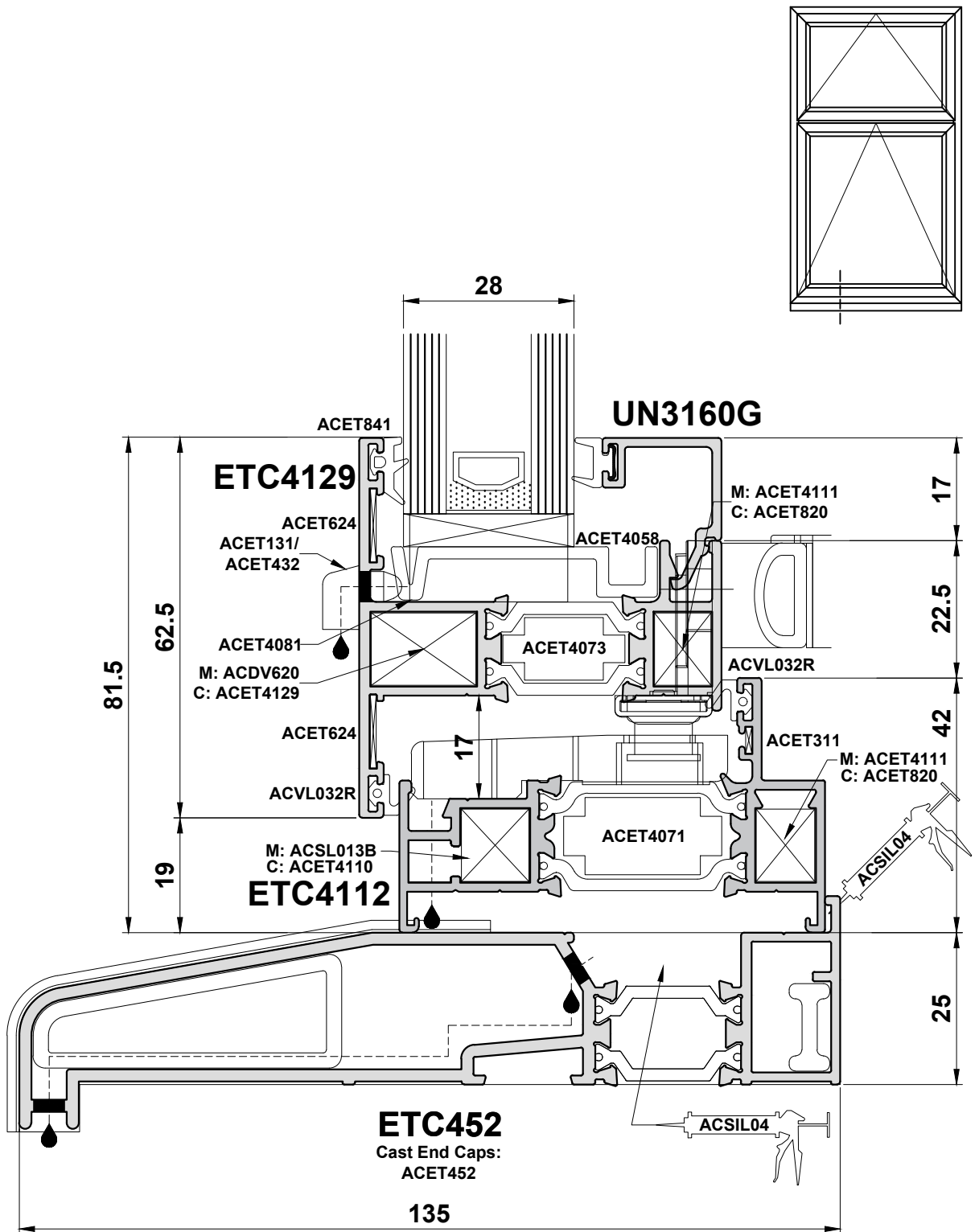
Detail 8A



Cill end caps should be sealed to cill to prevent water egress over edge

Do Not Scale From This Drawing

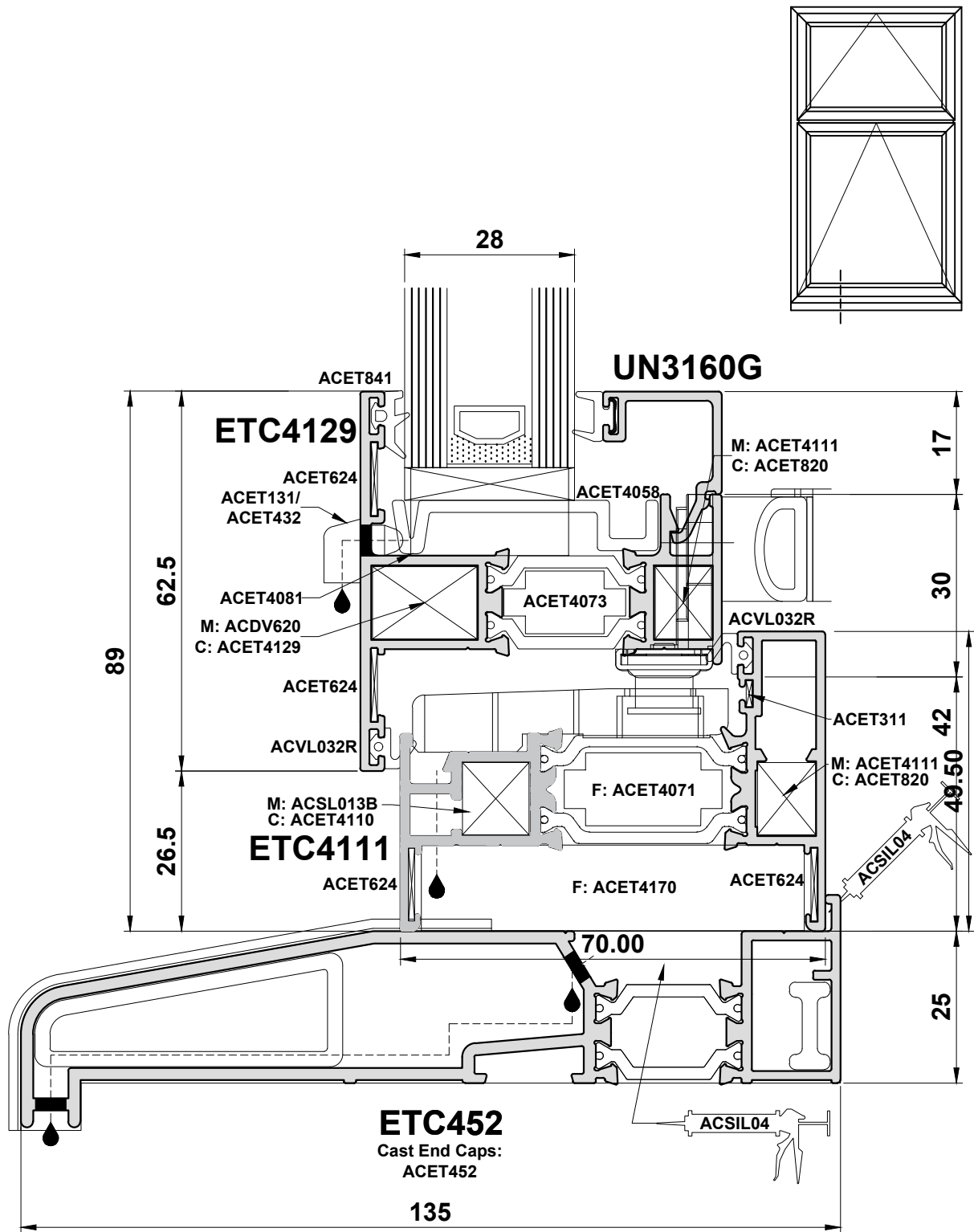
Detail 8B



Cill end caps should be sealed to cill to prevent water egress over edge

Do Not Scale From This Drawing

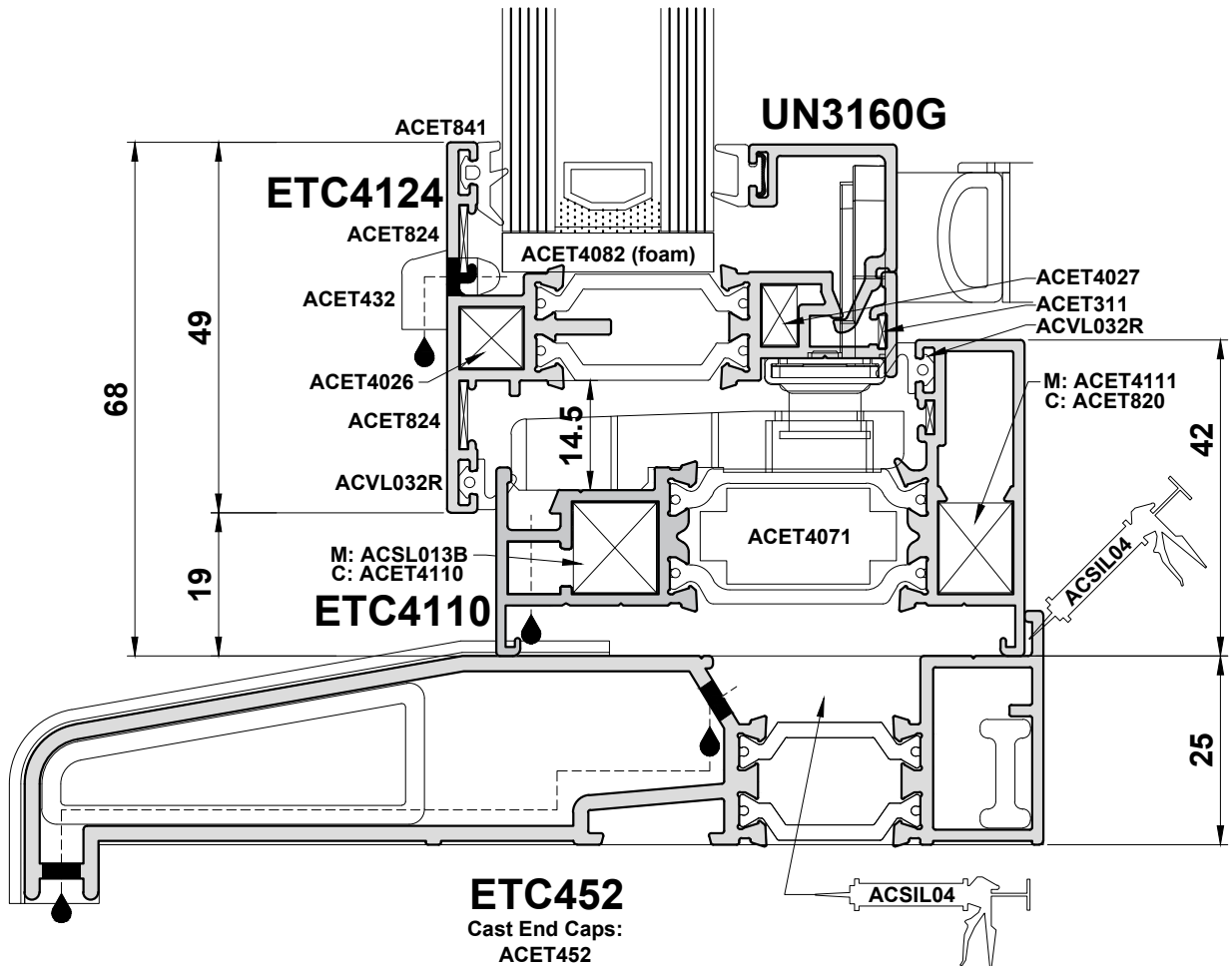
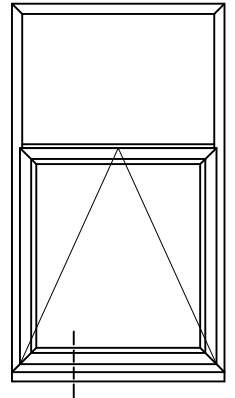
Detail 8C



Cill end caps should be sealed to cill to prevent water egress over edge

Do Not Scale From This Drawing

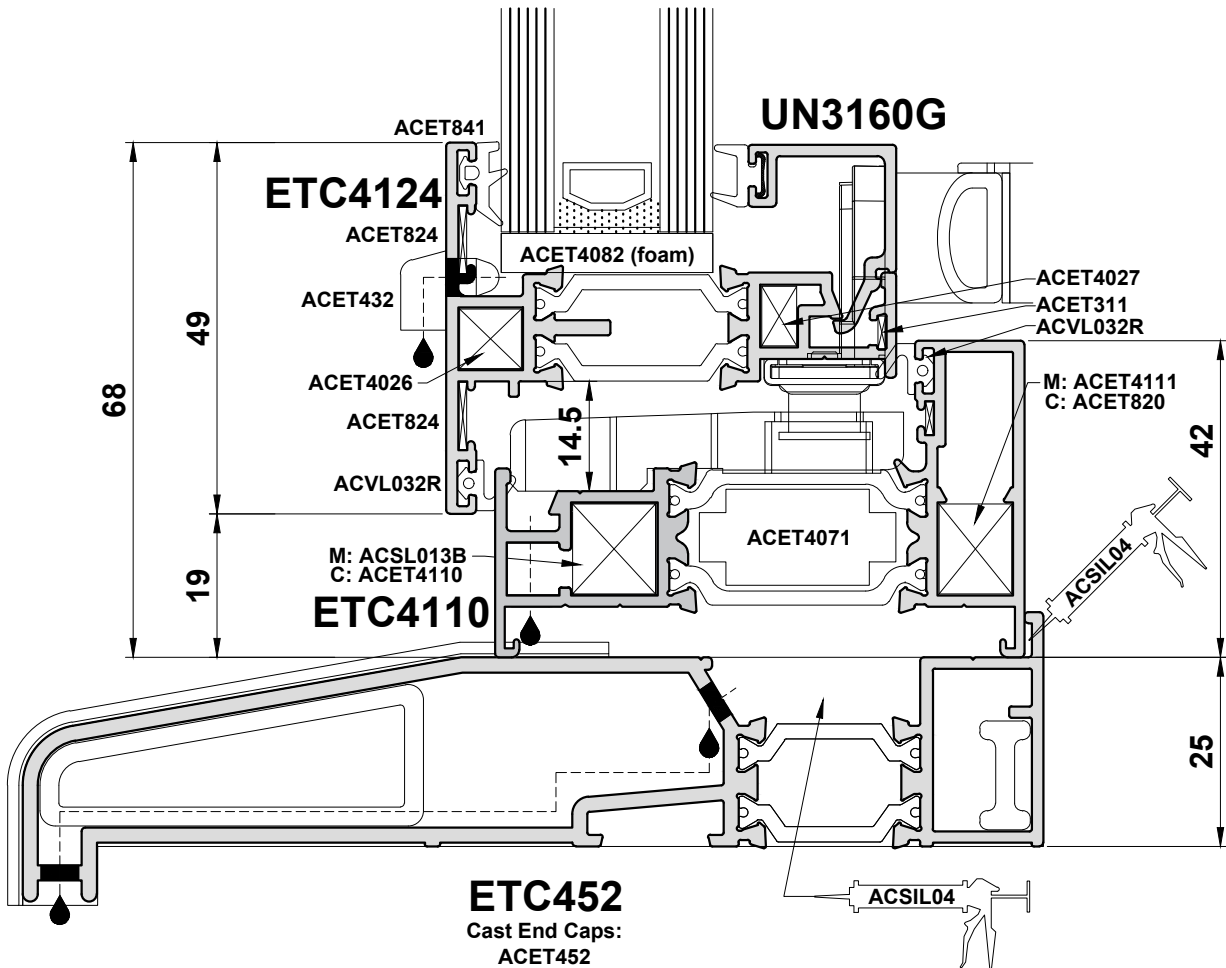
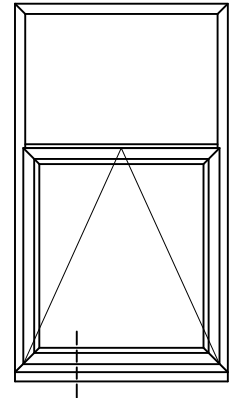
Detail 8D



Cill end caps should be sealed to cill to prevent water egress over edge

Do Not Scale From This Drawing

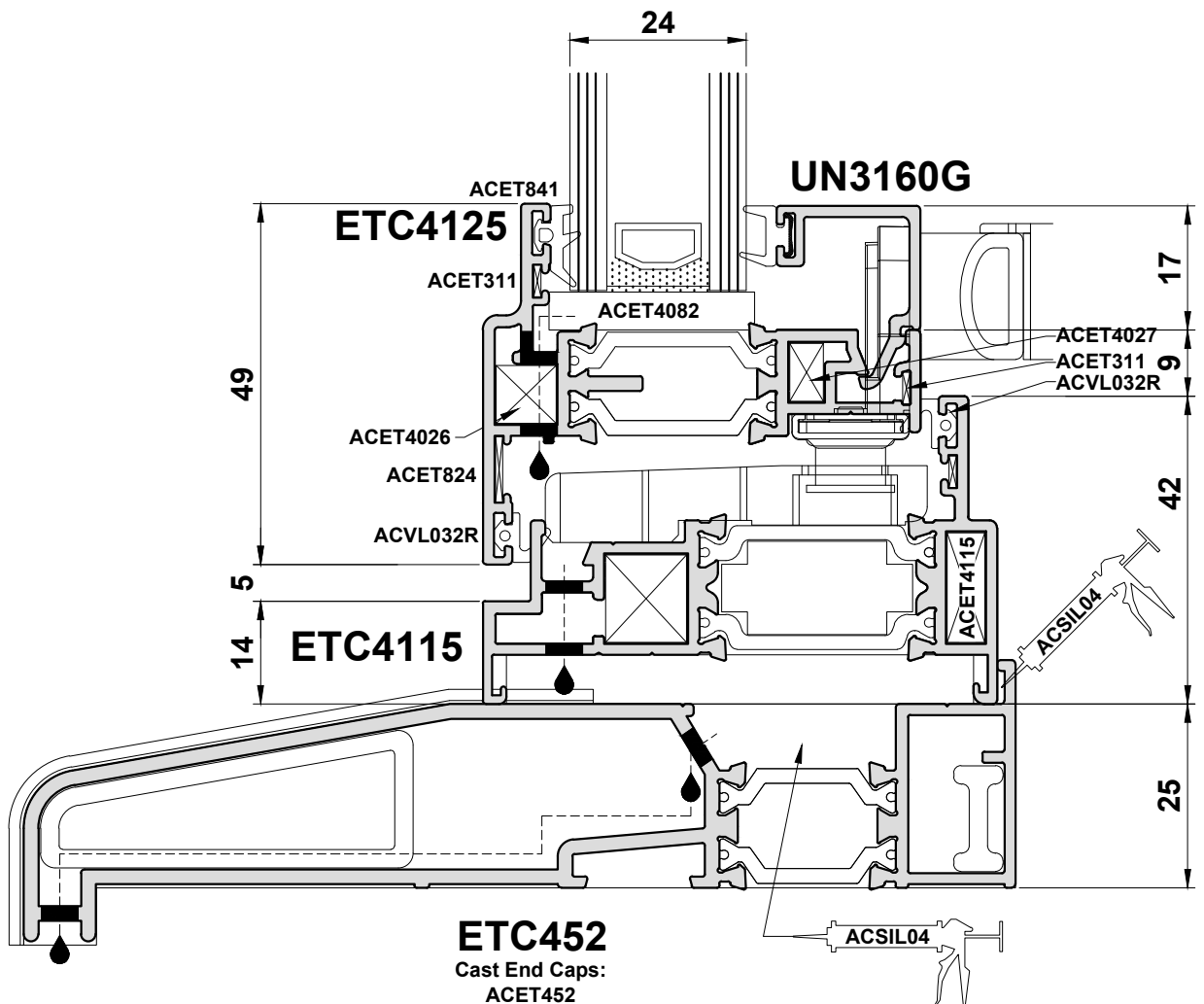
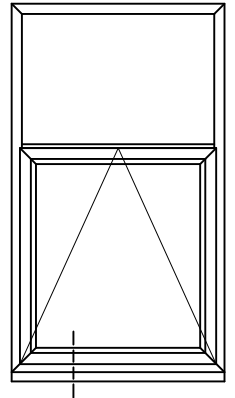
Detail 8E



Cill end caps should be sealed to cill to prevent water egress over edge

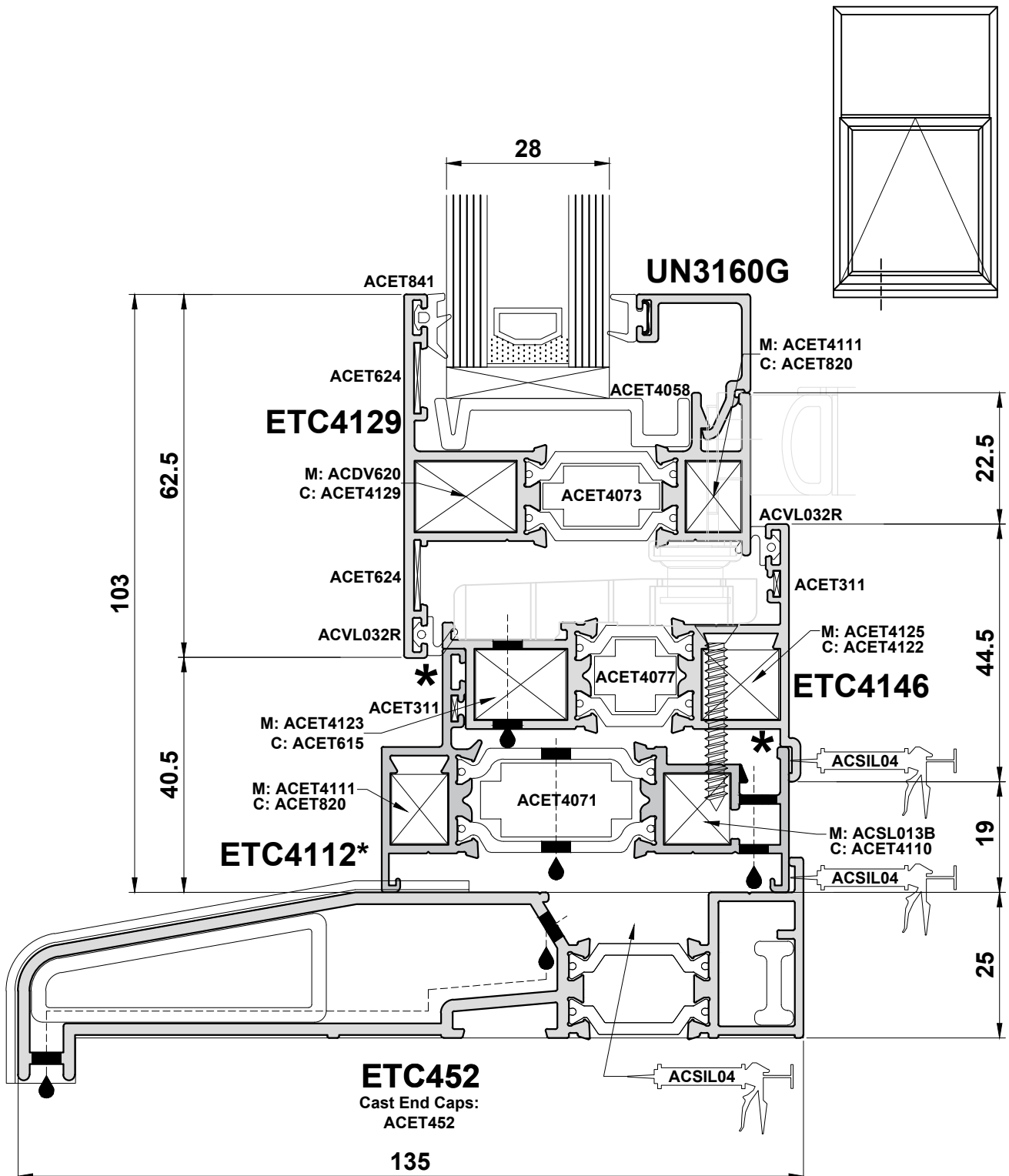
Do Not Scale From This Drawing

Detail 8F



Do Not Scale From This Drawing

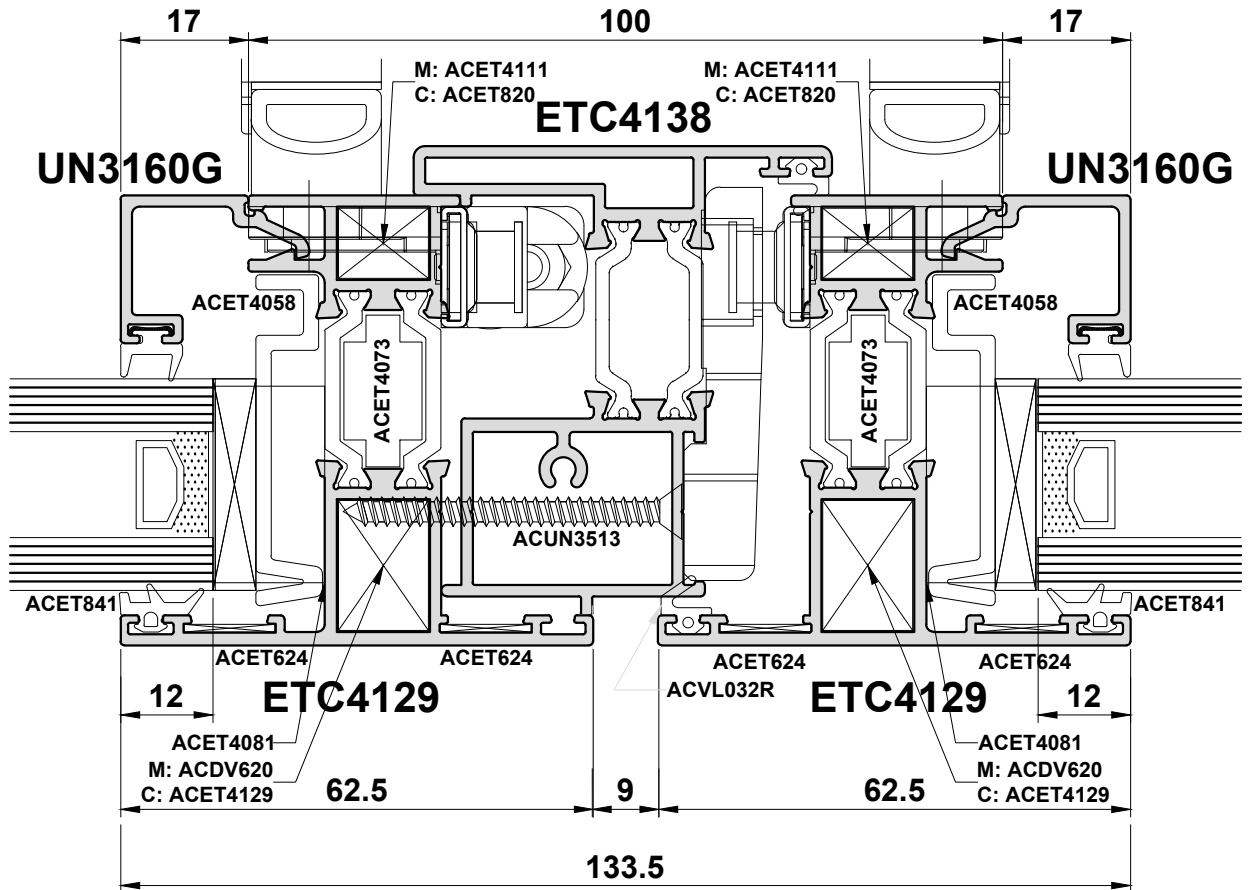
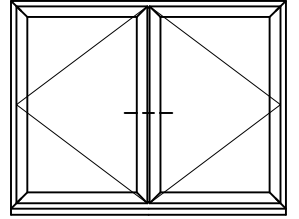
Detail 8G



*Note: Where ETC4146 is used, concealed drainage through a cill is required.
Cill end caps should be sealed to cill to prevent water egress over edge.

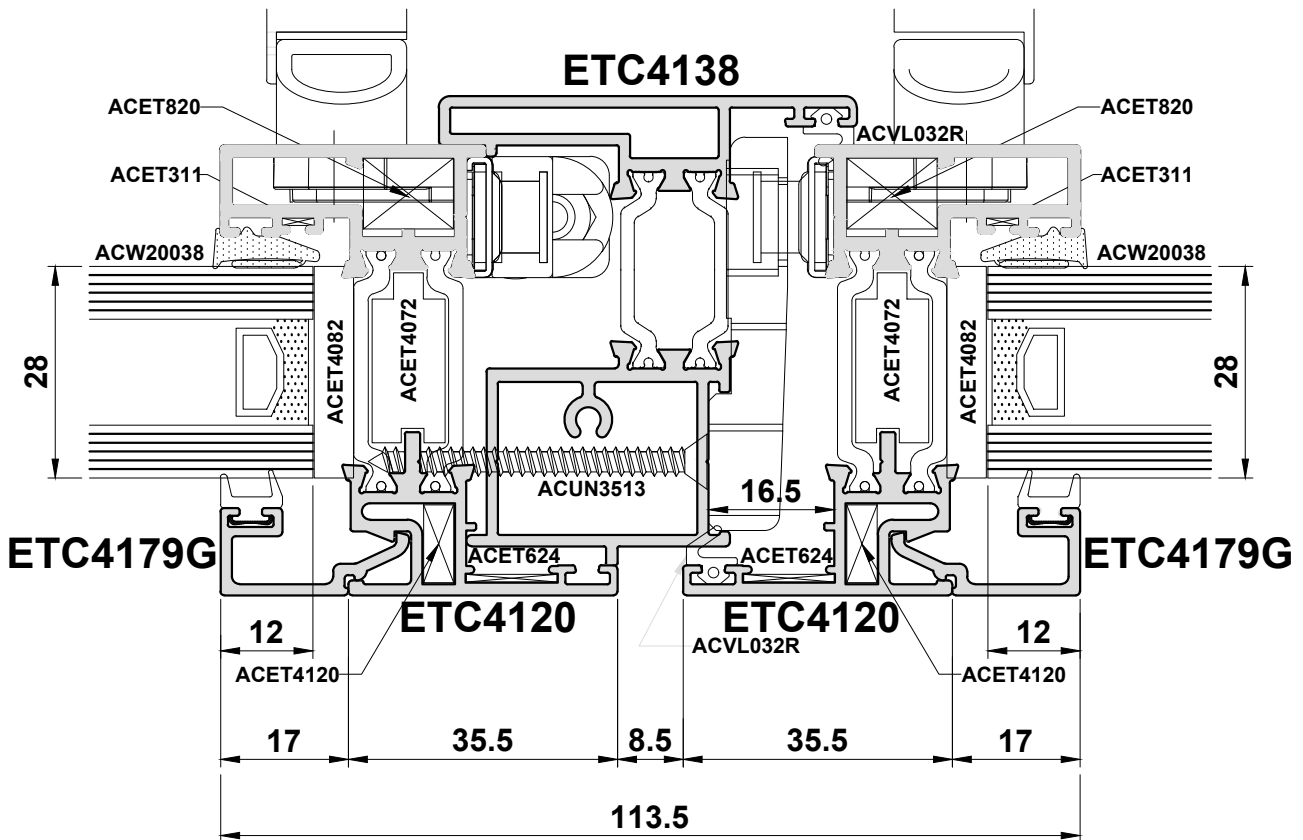
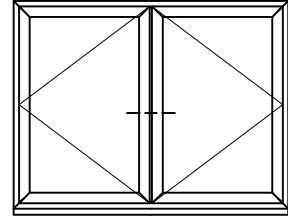
Do Not Scale From This Drawing

Detail 9A



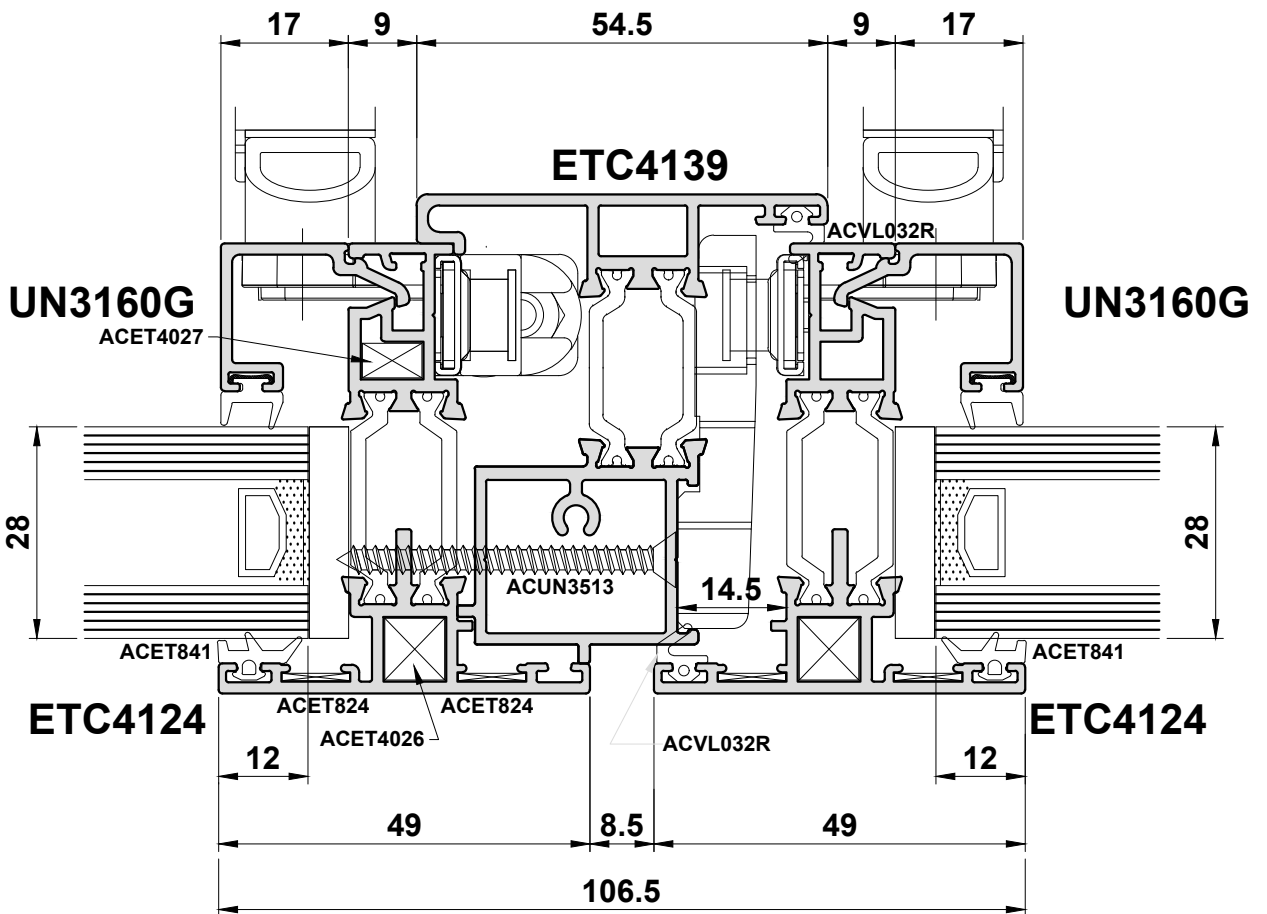
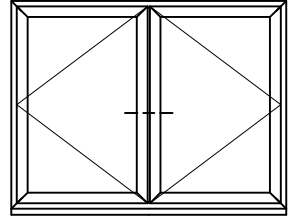
Do Not Scale From This Drawing

Detail 9B



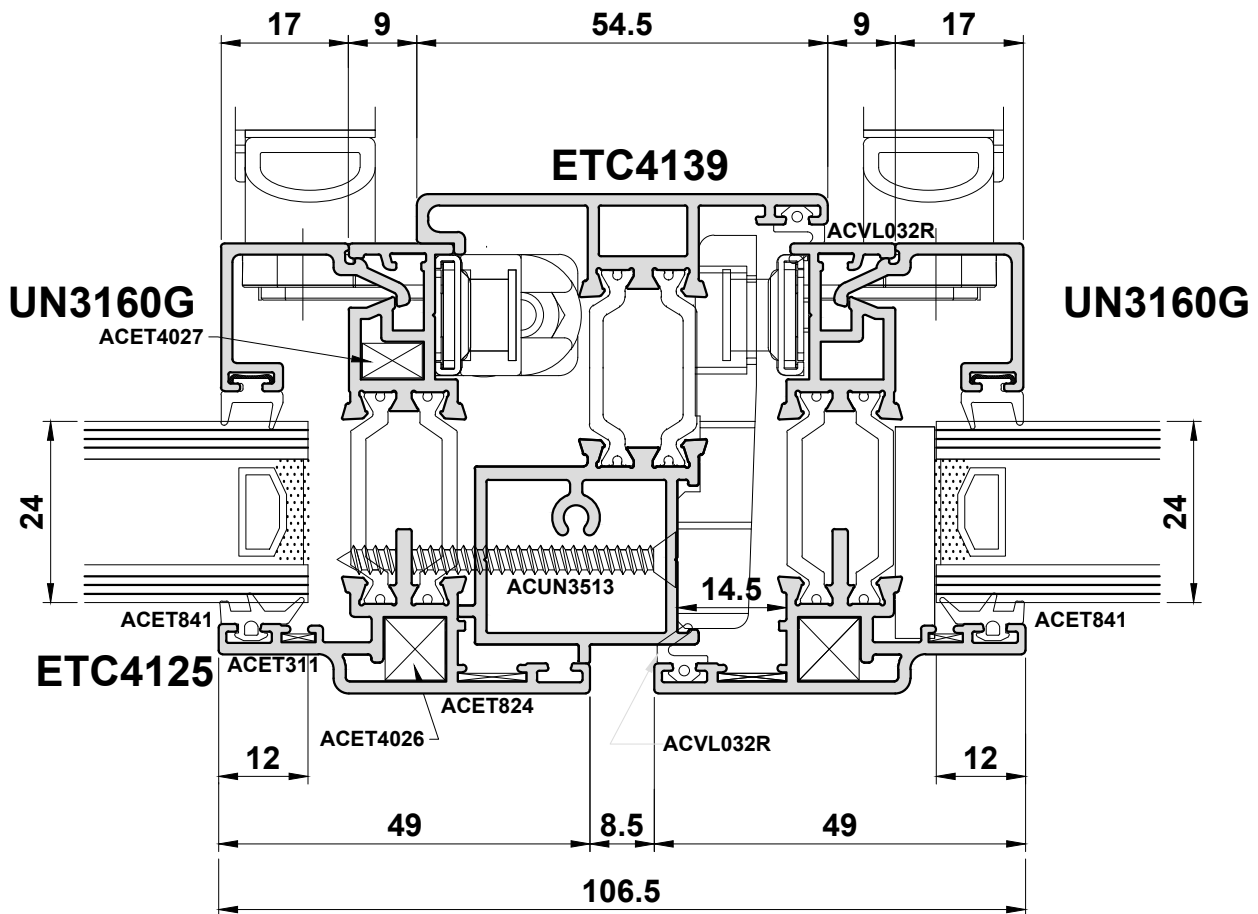
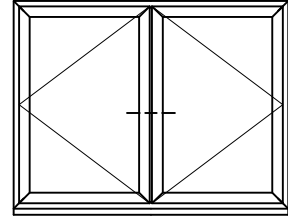
Do Not Scale From This Drawing

Detail 9C



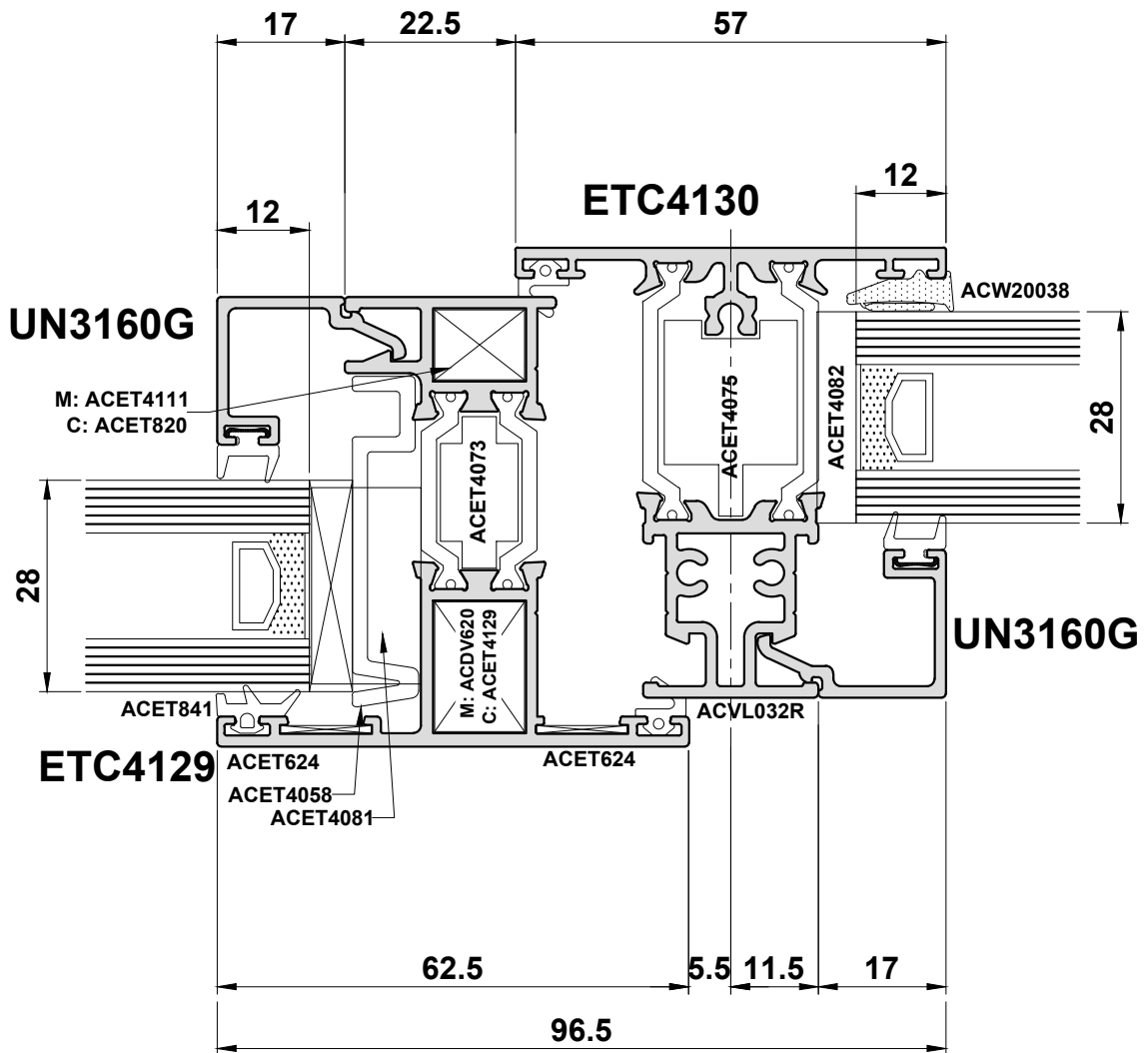
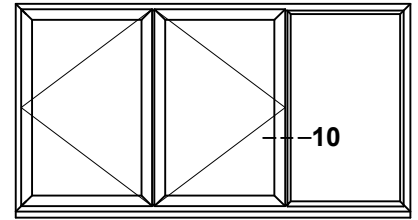
Do Not Scale From This Drawing

Detail 9D



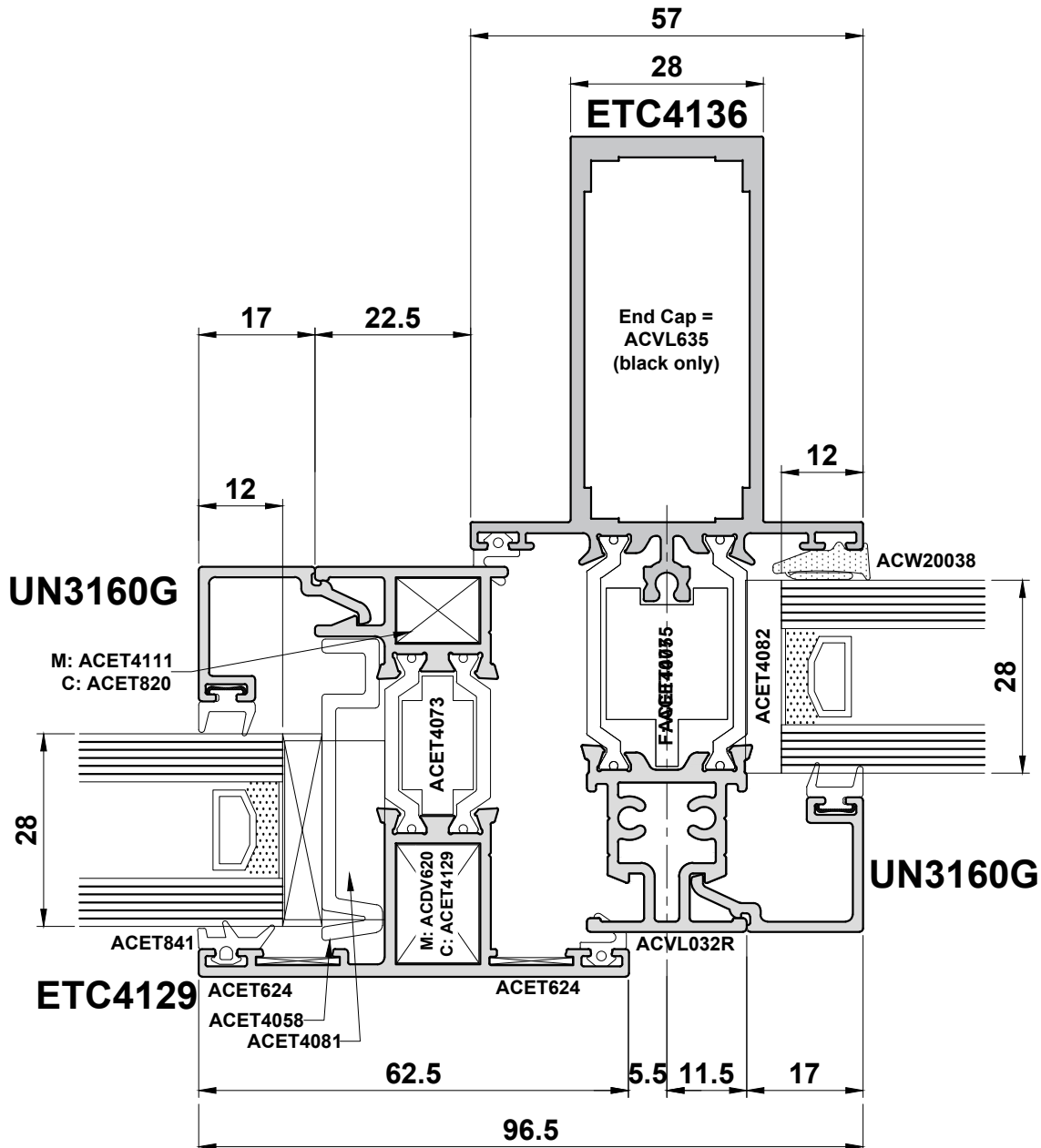
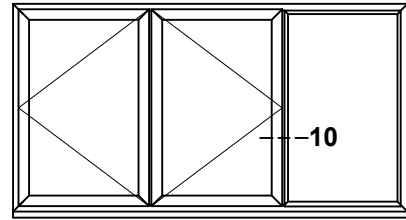
Do Not Scale From This Drawing

Detail 10A



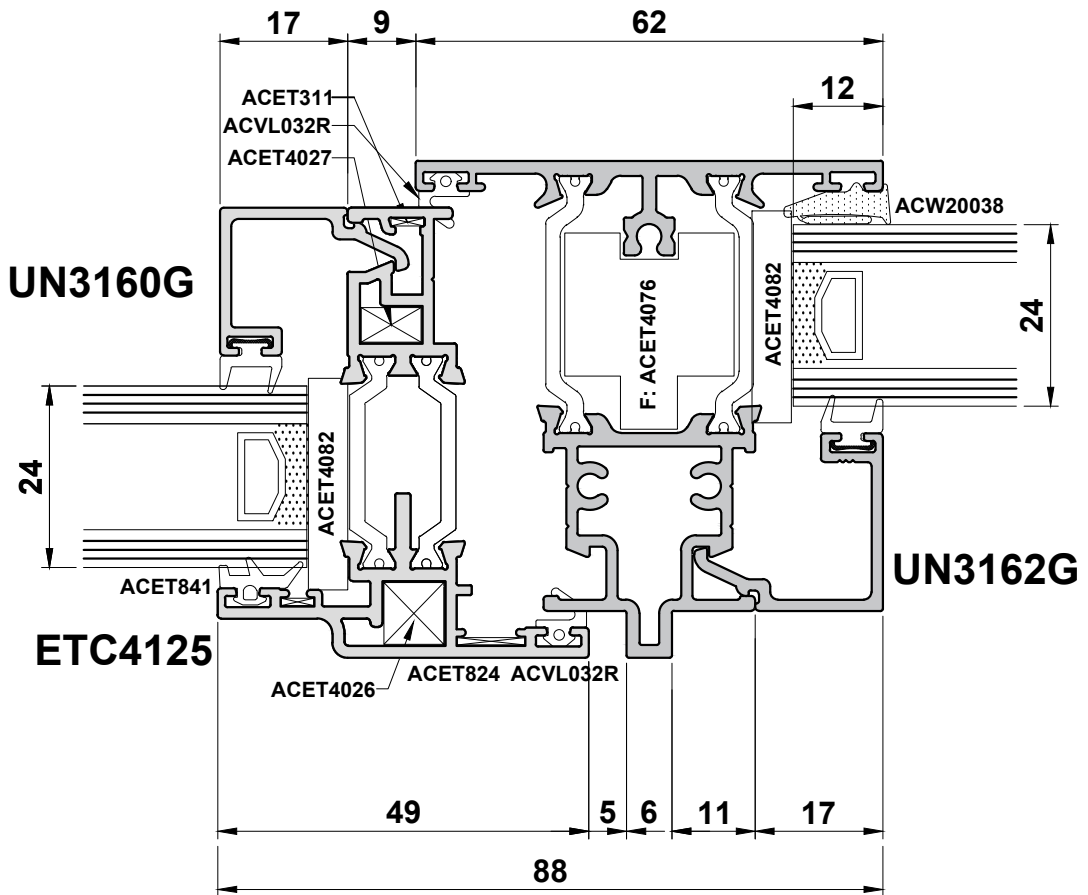
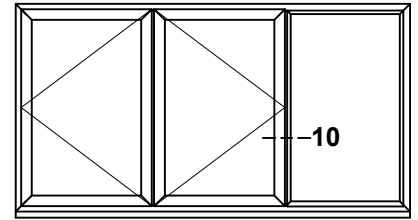
Do Not Scale From This Drawing

Detail 10B

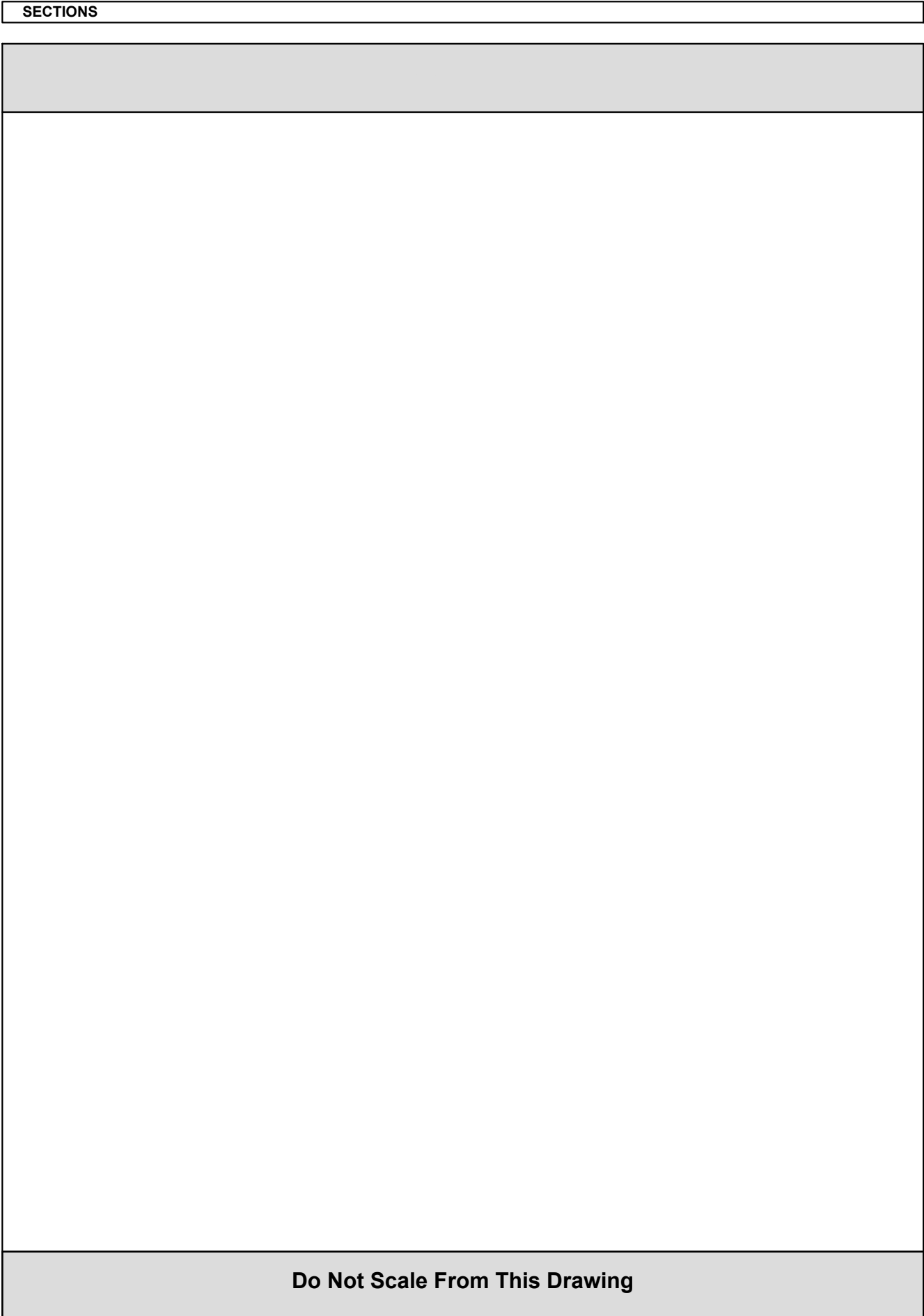


Do Not Scale From This Drawing

Detail 10C



Do Not Scale From This Drawing



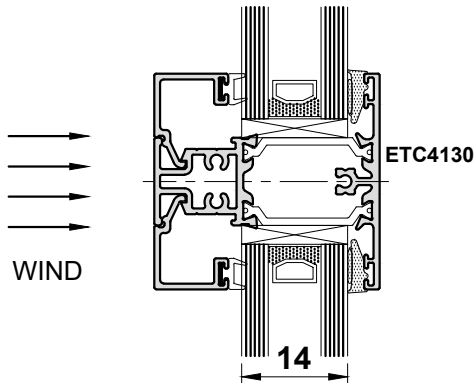
Do Not Scale From This Drawing

Section D

Statics

**General Size Limitations are shown on Page A06.
Please also consider maximum limits of accessories.**

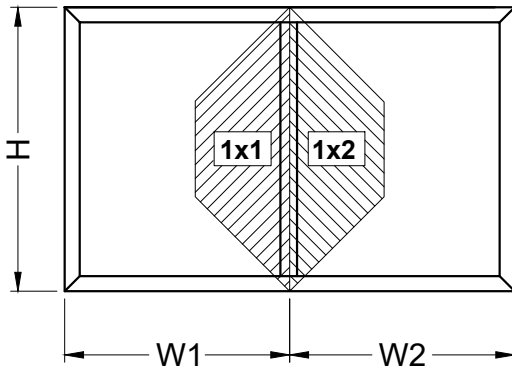
**For Wind Loading Limitations, Please Contact
The Technical Department - T: 01934 833100**



The position of the axes is an indication for the use and application of the moments of inertia (I_x and I_y) and the section modulus (W_x and W_y). We always choose the values of the axis perpendicular to the load to resist it.

- To resist the wind loads we use the values I_x and W_x .

EXAMPLE



$H = 175\text{cm}$

$W1 = 120\text{cm}$

$W2 = 100\text{cm}$

$P = 1250\text{ Pa}$ (wind pressure)

- 1) Determine I_{xx} value for the stiles (if required) using the Specification Wizard

$I_{xx} = 21.0\text{ cm}^4$

- 2) Determine suitability



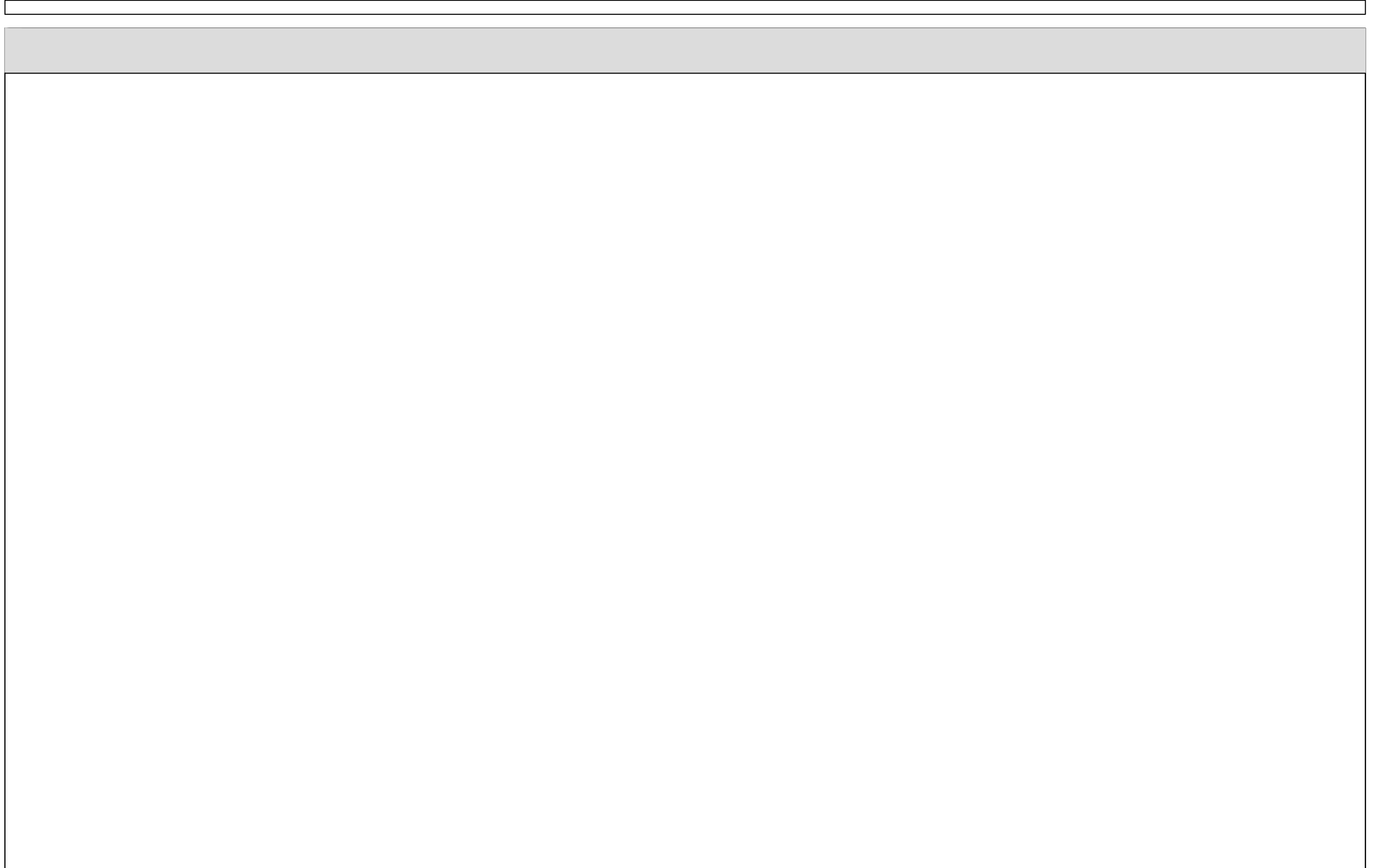
Number	Picture	$I_x(\text{cm}^4)$ $w_x(\text{cm}^3)$	$I_y(\text{cm}^4)$ $w_y(\text{cm}^3)$
ETC4130		19.39	4.66
		5.84	1.63
ETC4135		23.74	6.51
		6.30	2.11
ETC4136		95.03	9.13
		15.97	3.21

Section E



Construction Drawings

Corner Joint Details.....	E03 - E05
ACET963 Punch Tool.....	E06
Variable angle Cleats.....	E07
Bead Notching ACVD916.....	E08
Drainage.....	E09 - E11
Angled Sub Cill.....	E12
Transom/Mullion Fixing Details.....	E13 - E16
Friction Hinge Details.....	E17 - E19
ACET4050 Hinge Details.....	E20
Locking Details.....	E21 - E23
French Casement Assembly.....	E24 - E25
Glazing Details.....	E26 - E34
Bay Pole Options.....	E35 - E36
Horizontal Coupler Details.....	E37
Fixing Strap Details.....	E38
Trickle Vent Details.....	E39



Corner Joint Details

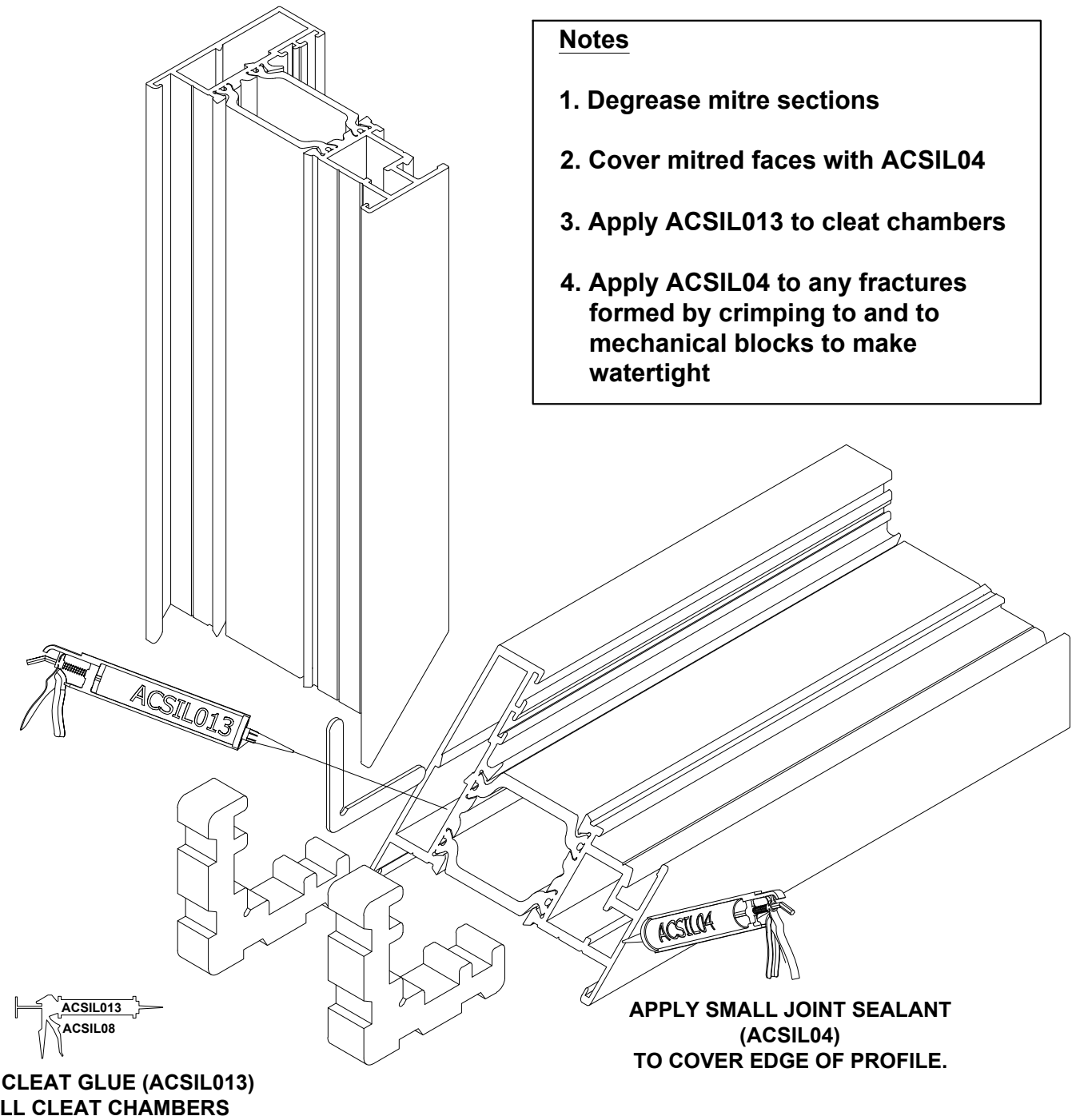
To ensure accurate corners, we recommend the use of support blocks (by others) whilst cutting. Do NOT clamp directly onto the polyamide.

Table 1

KL Colour	Sealant Part Number
Black	ACSIL04BL
White	ACSIL04WP
Clear	ACSIL04CL
KL001	ACSIL04KL001
KL002	ACSIL04KL002
KL003	ACSIL04KL003
KL004	ACSIL04KL004
KL005	ACSIL04KL005
KL006	ACSIL04KL006
KL007	ACSIL04KL007
KL010	ACSIL04KL010
KL011	ACSIL04KL011
KL012	ACSIL04KL012
KL013	ACSIL04KL013

Notes

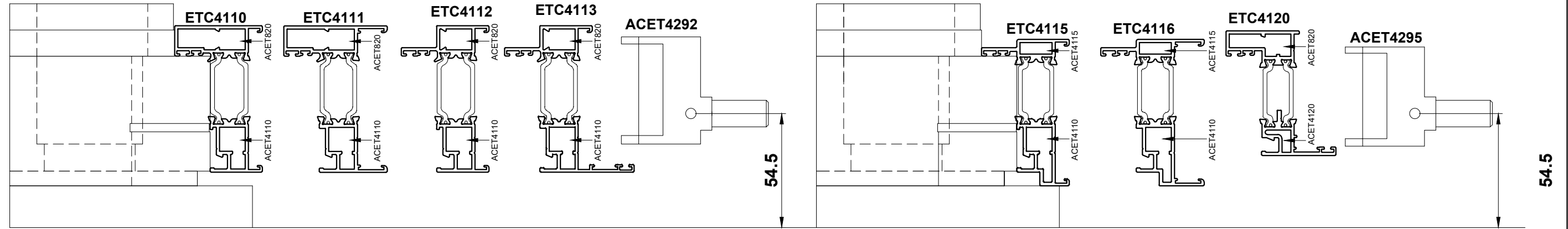
1. Degrease mitre sections
2. Cover mitred faces with ACSIL04
3. Apply ACSIL013 to cleat chambers
4. Apply ACSIL04 to any fractures formed by crimping to and to mechanical blocks to make watertight



Do Not Scale From This Drawing

Corner Crimping without Integrated Gasket

Manual Crimper = WUT024HSZA

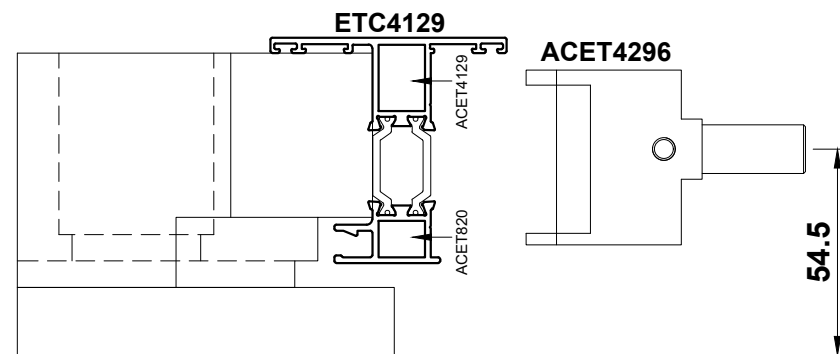


ACET4291N
Vee Block
& Packer

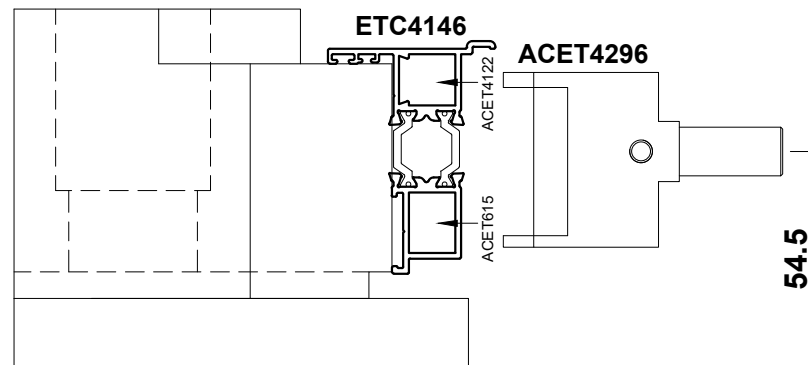
ACET4296

ACET4291N
Vee Block
& Packer

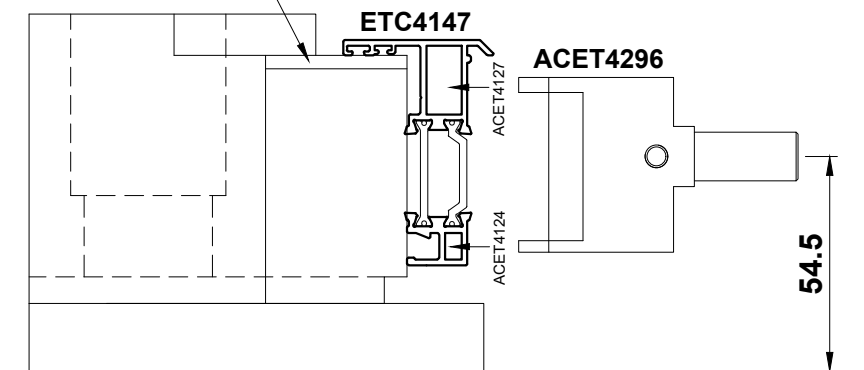
ACET4297
Packer



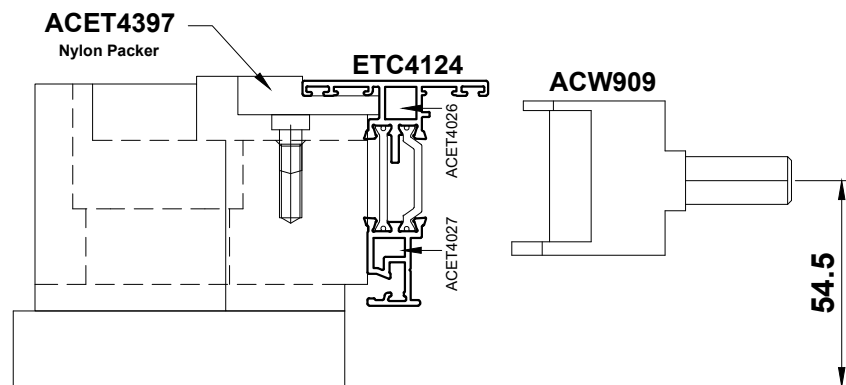
ACET4299



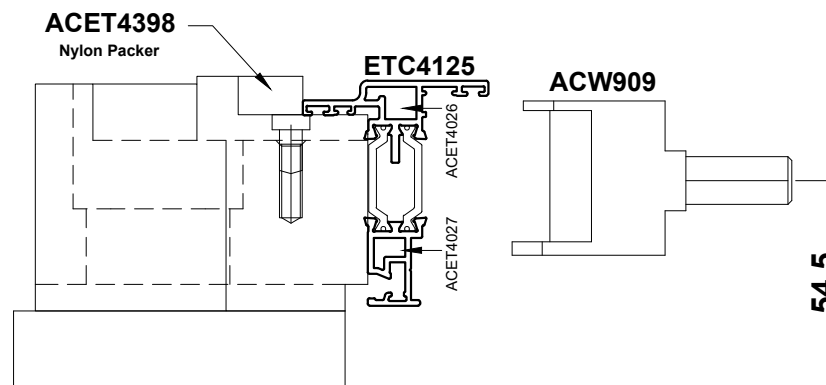
ACET4291N
Vee Block
& Packer



ACET4291N



ACW906

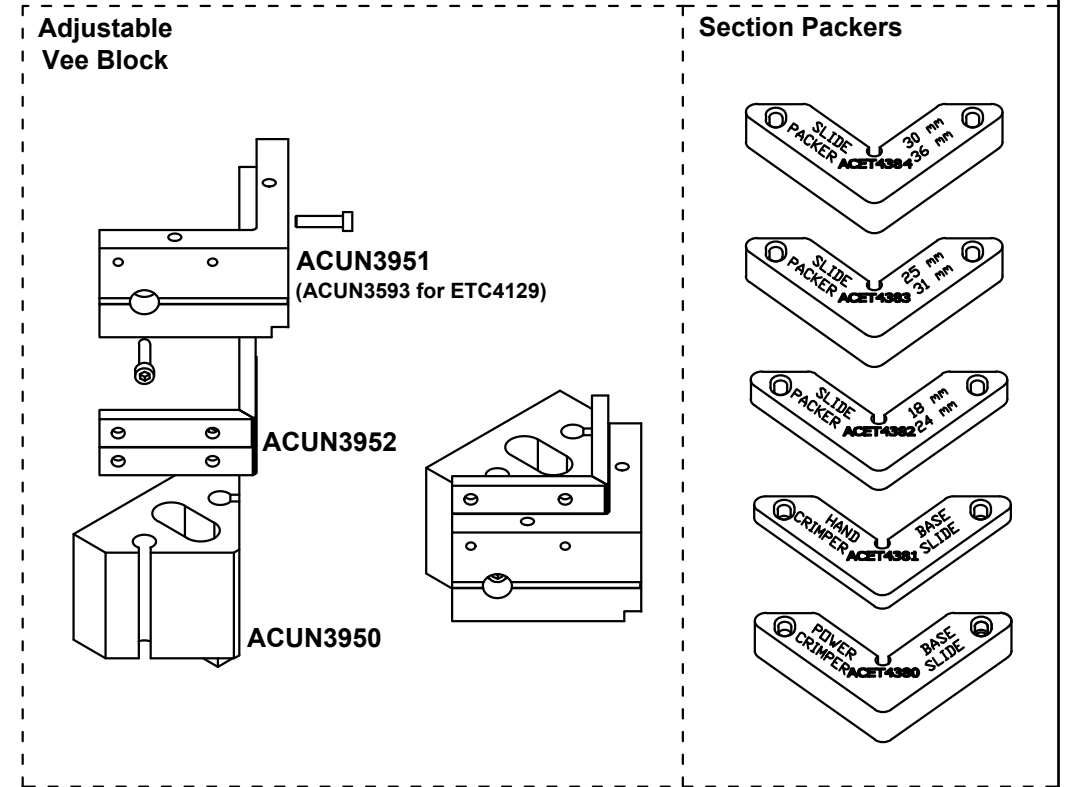
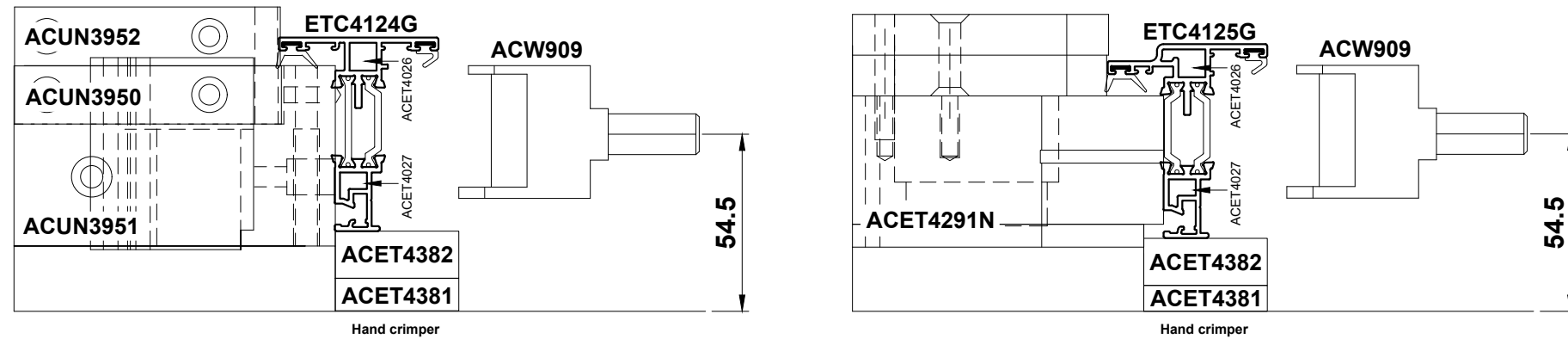
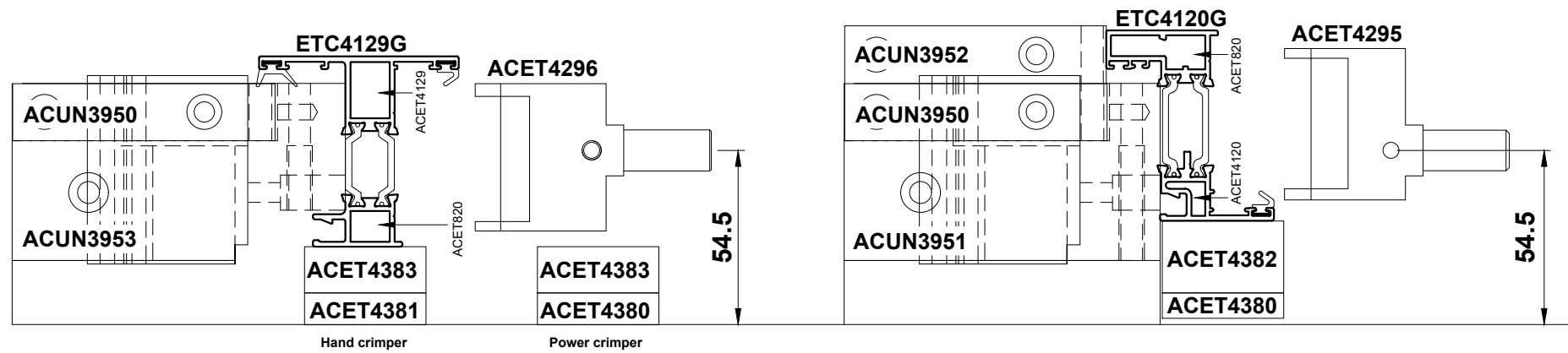
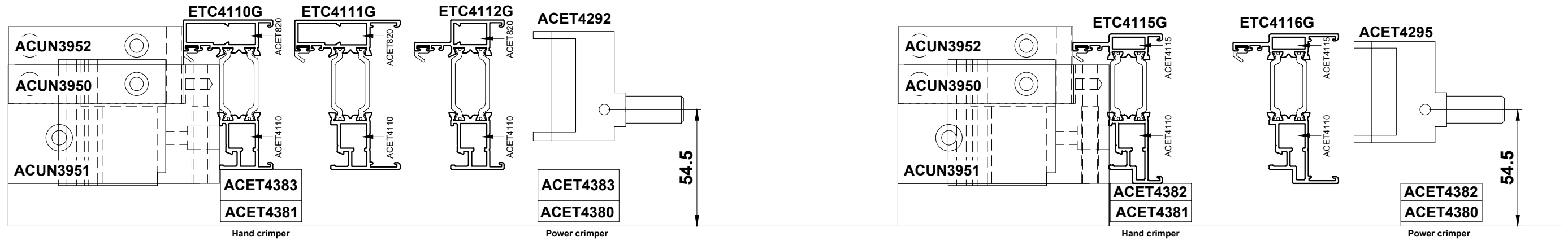


ACW906

Do Not Scale From This Drawing

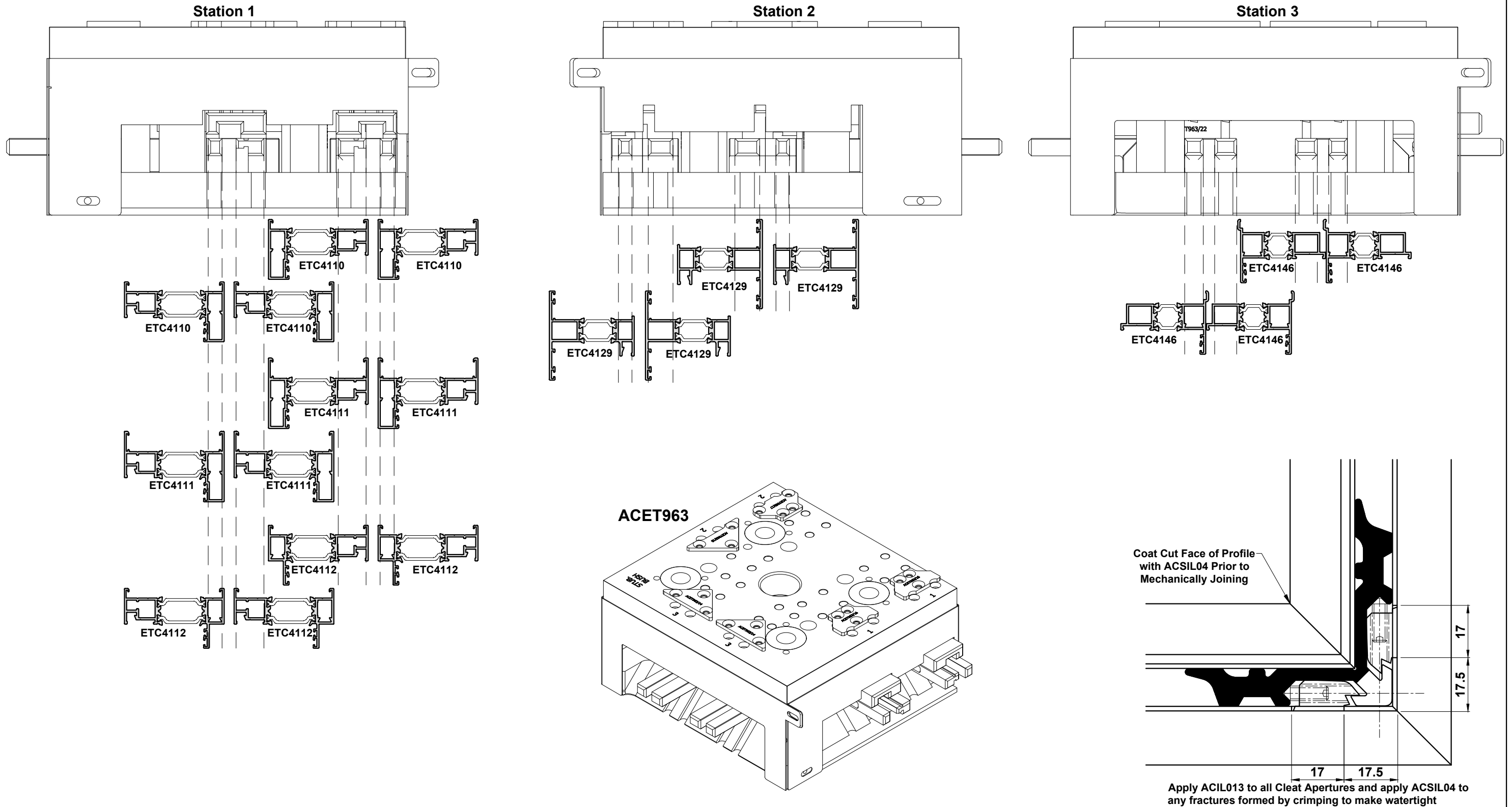
Corner Crimping with Integrated Gasket

Manual Crimper = WUT024HSZA



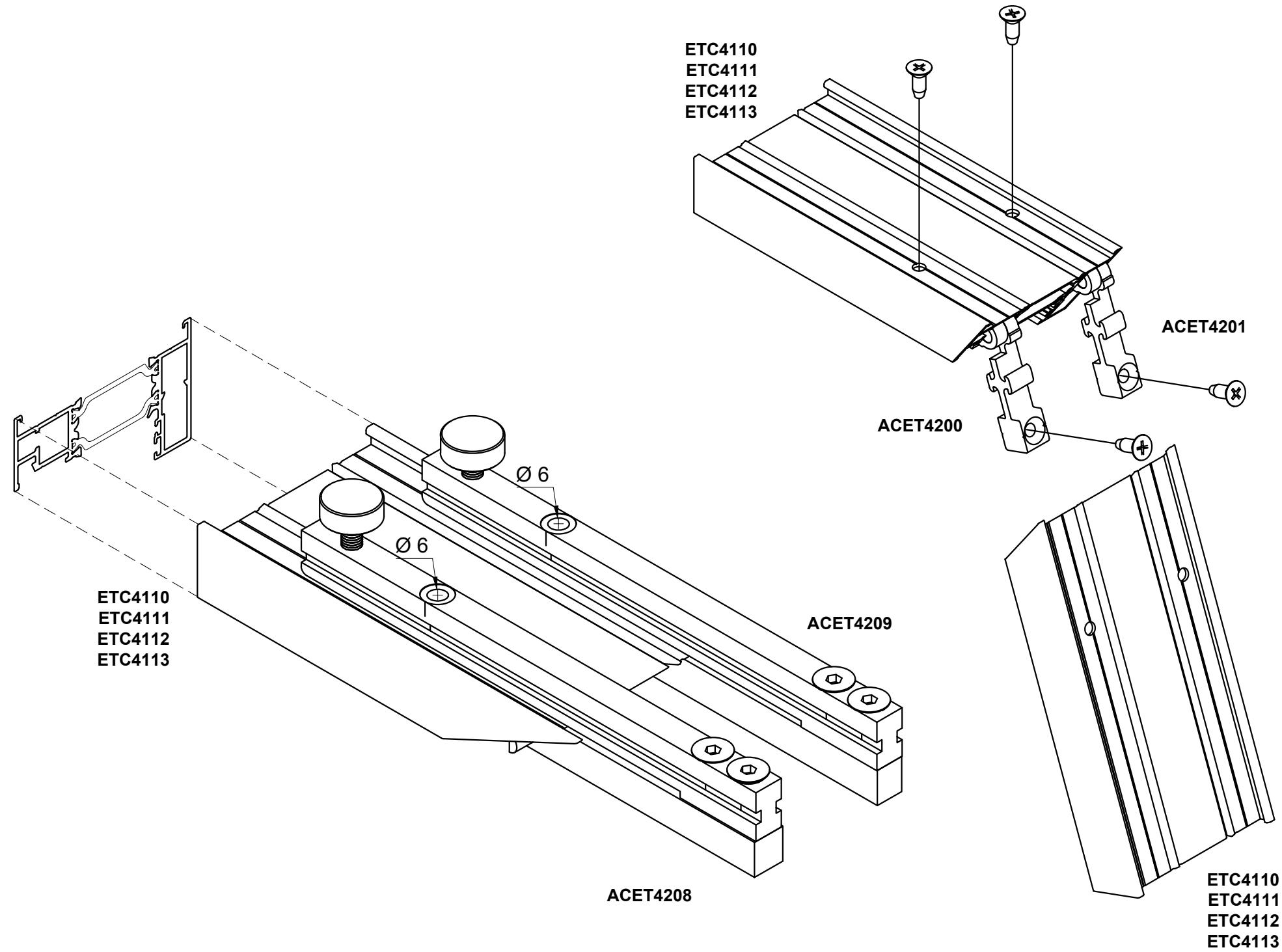
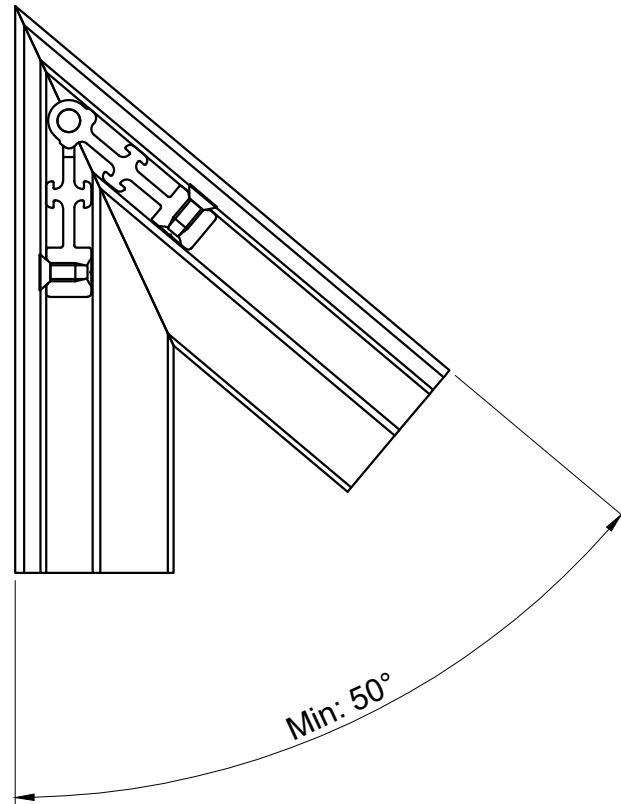
Do Not Scale From This Drawing

ACET963 Punch Tool



Do Not Scale From This Drawing

Variable Angle Cleats



Do Not Scale From This Drawing

Bead Notching ACVD916

LOCK SELECTION NOTES:

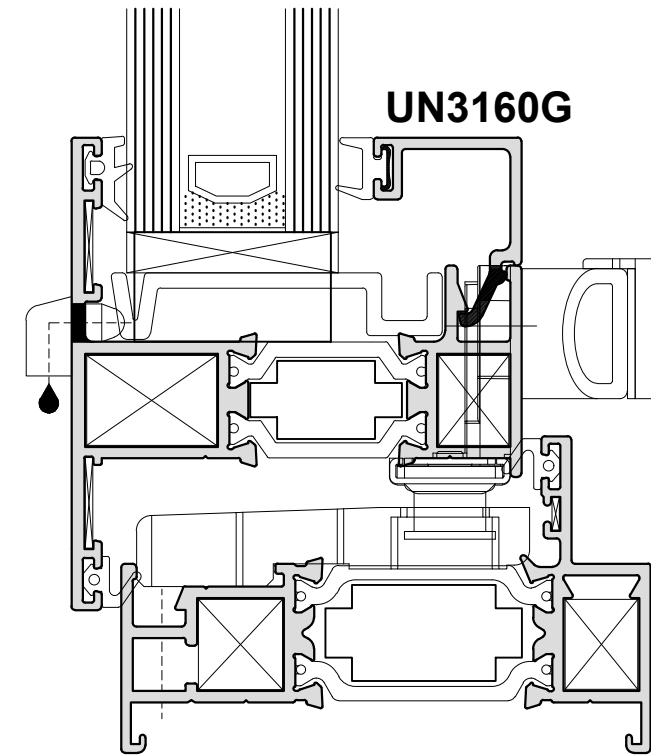
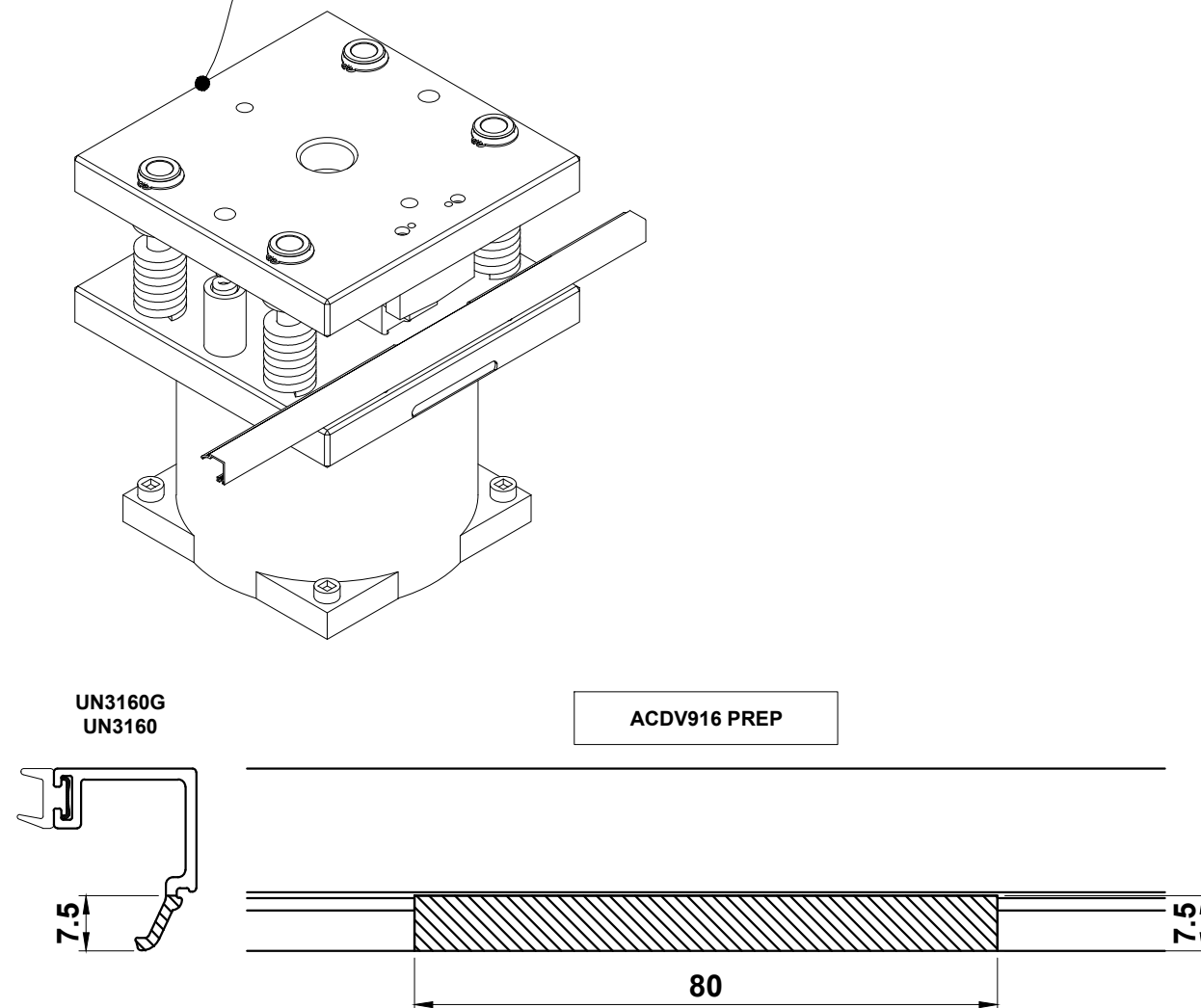
PLEASE FOLLOW TABLE ON PAGE E06 FOR LOCK SELECTION OPTIONS.

ALL SASH / LOCK COMBINATIONS REQUIRE BEAD NOTCHING.

ALL OTHER INTERMEDIATE SHOOTBOLT COMBINATIONS REQUIRE BEAD NOTCHING.

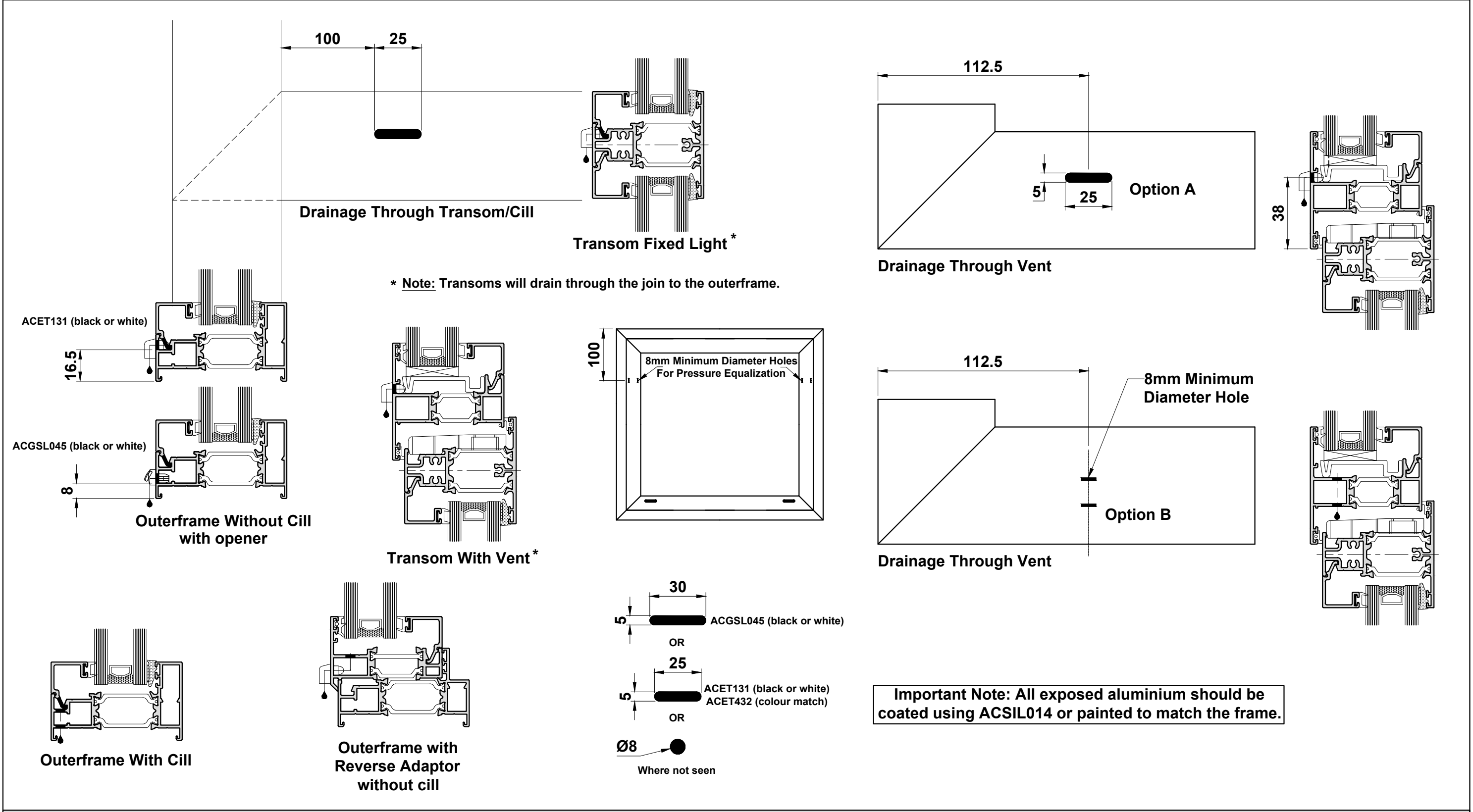
ALL LOCKS & SASHES HAVE BEEN TESTED TO PAS24:2016. PLEASE FOLLOW PAS24:2016 FABRICATION INSTRUCTIONS AND LIMITATIONS.

USE ACDV916 PUNCH TOOL FOR BEAD NOTCHING.

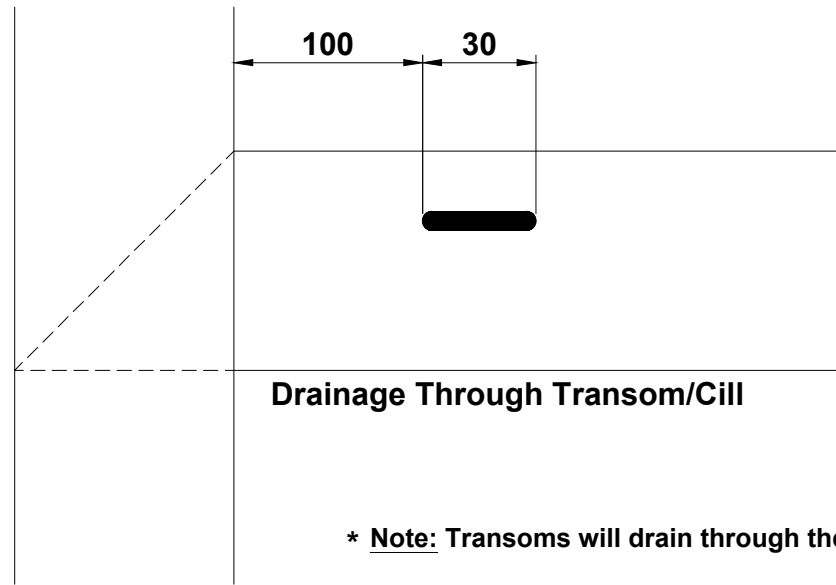


Do Not Scale From This Drawing

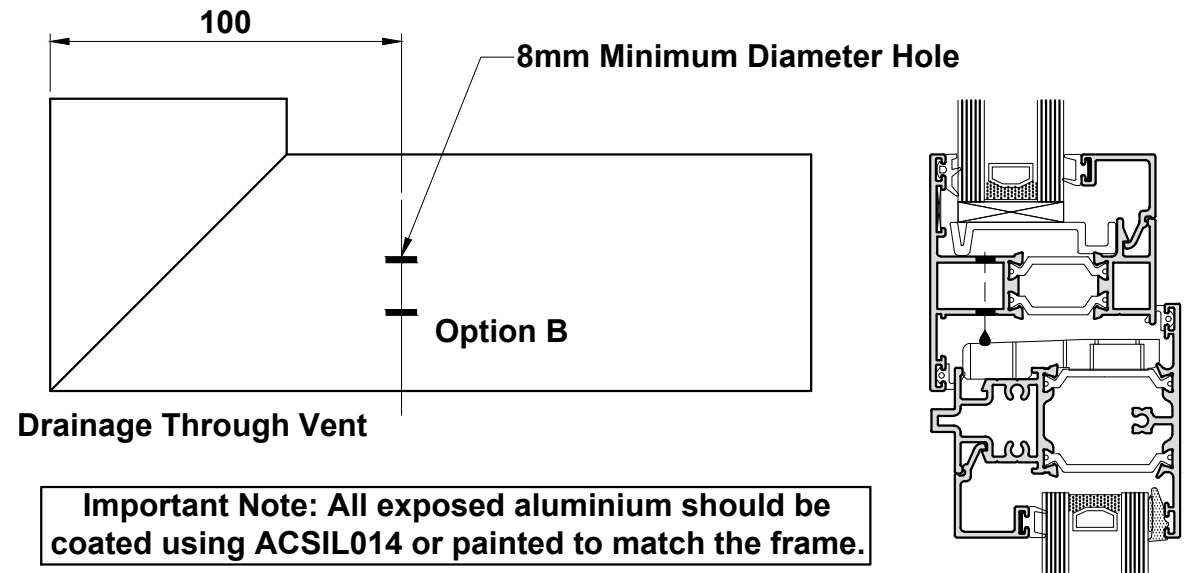
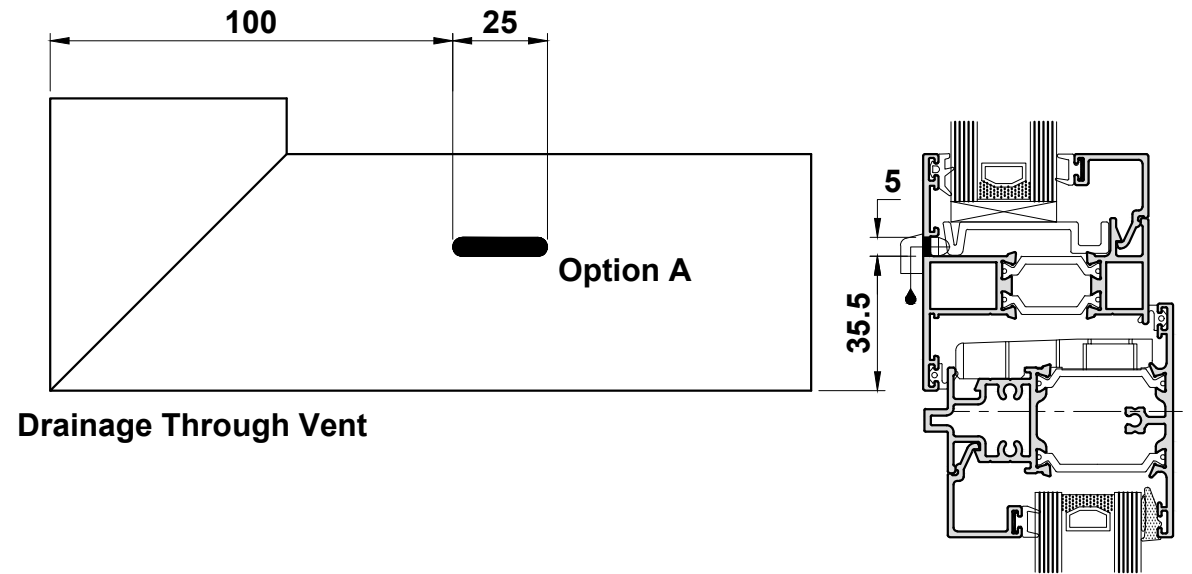
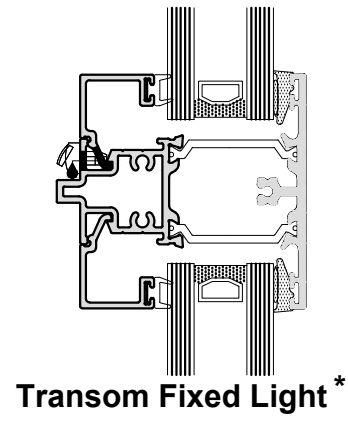
Drainage



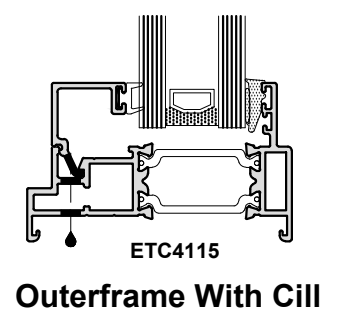
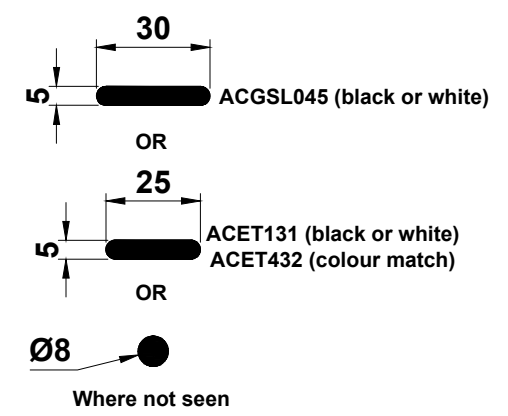
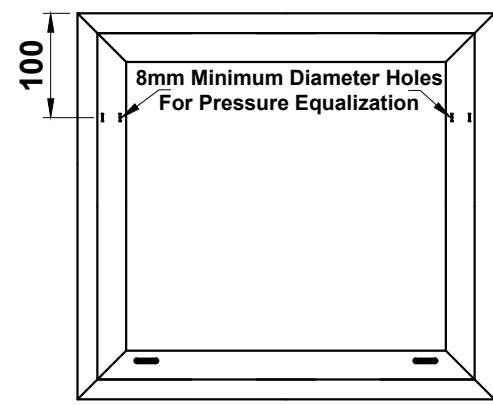
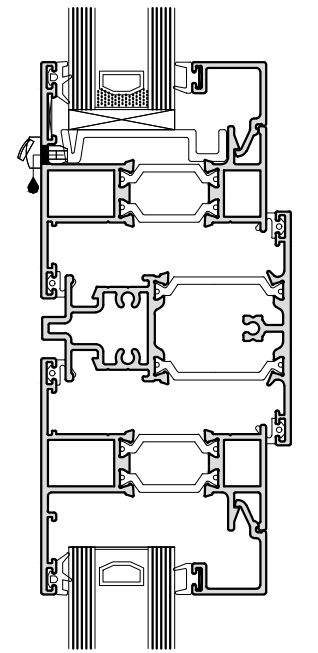
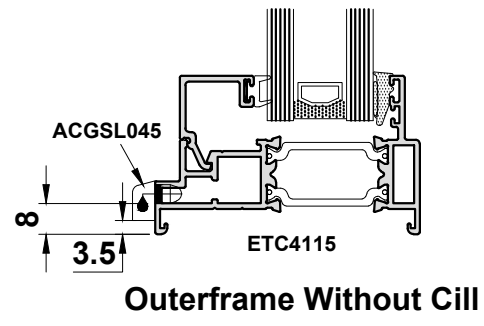
Flush Casement Drainage



* **Note:** Transoms will drain through the join to the outerframe.

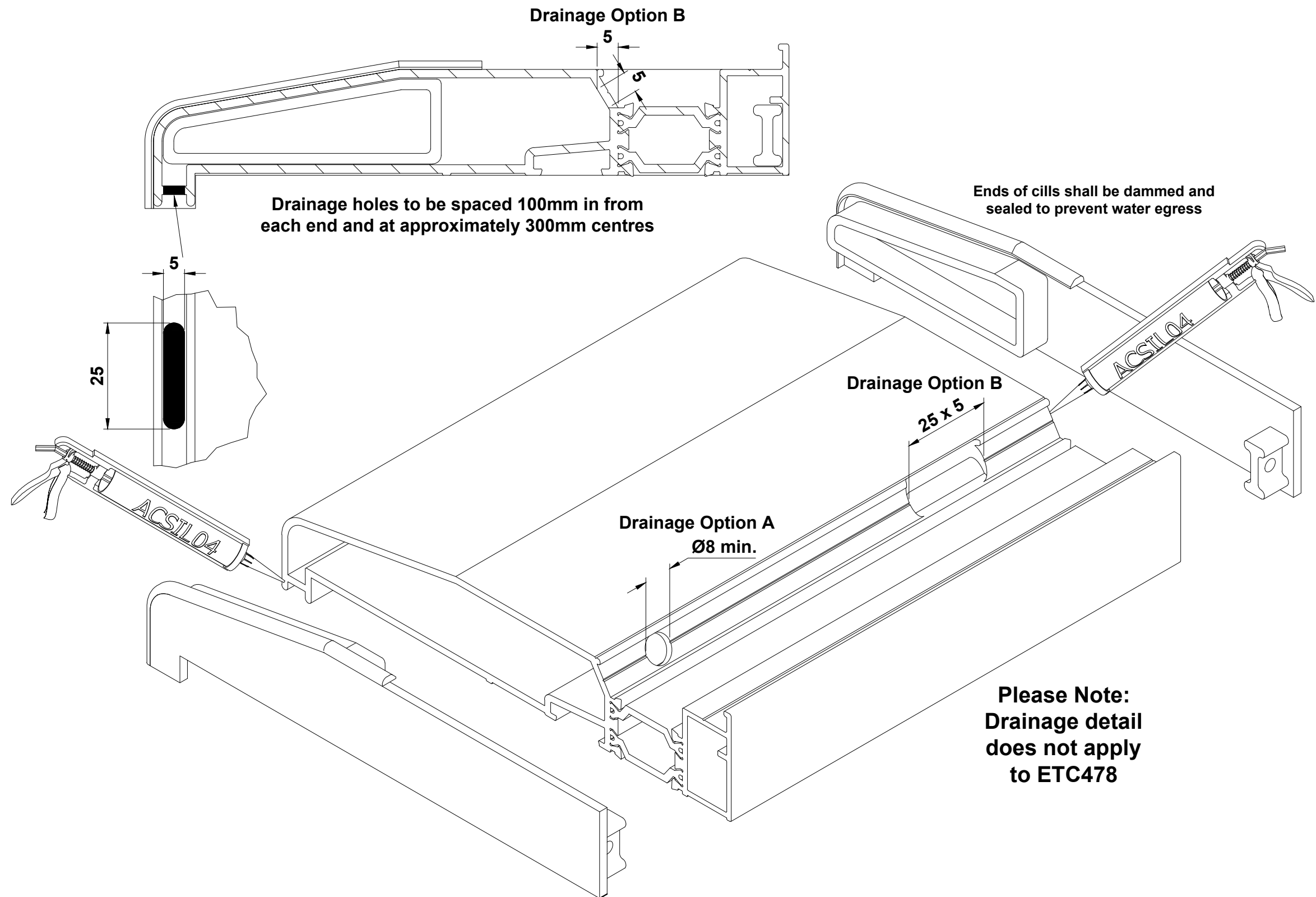


Important Note: All exposed aluminium should be coated using ACSIL014 or painted to match the frame.



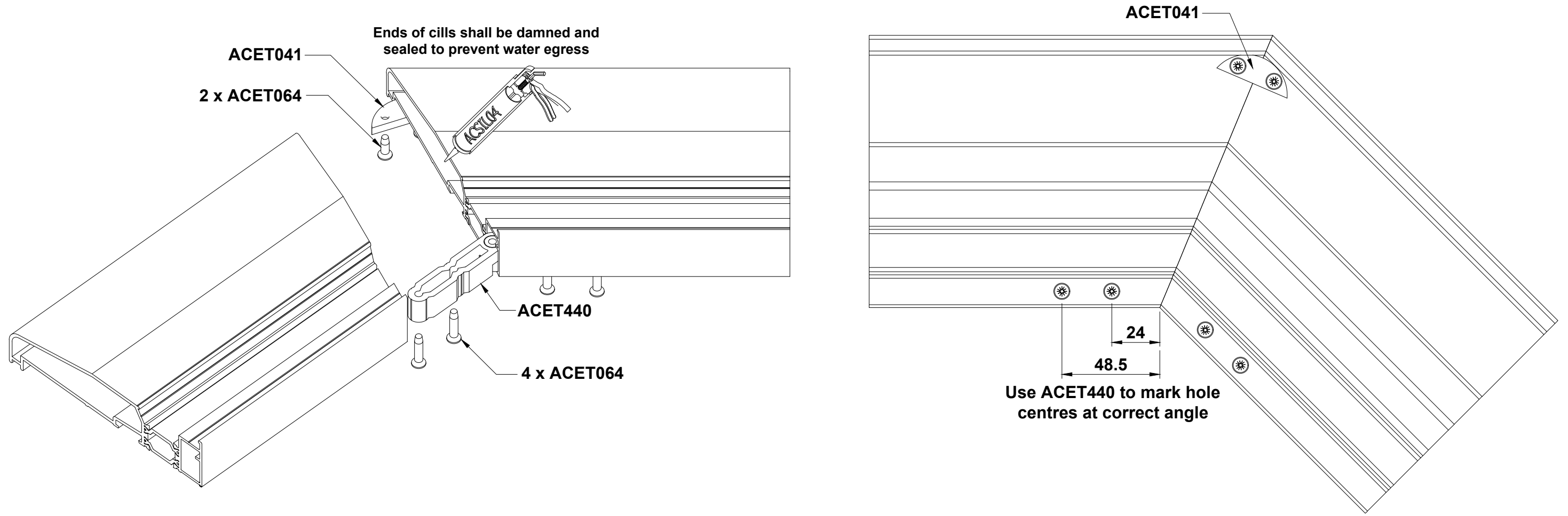
Do Not Scale From This Drawing

Sub Cill Drainage



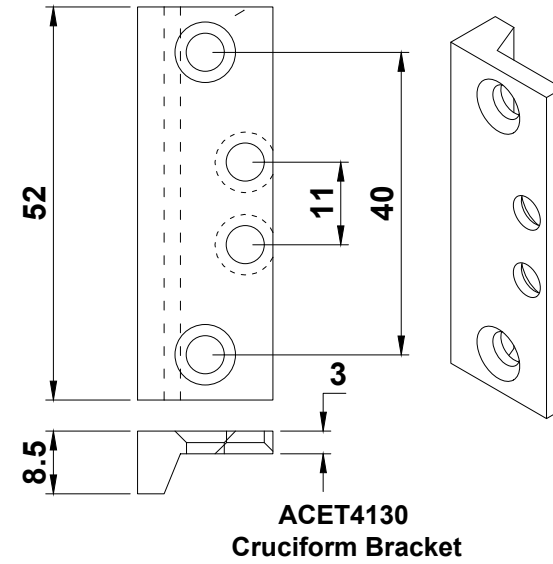
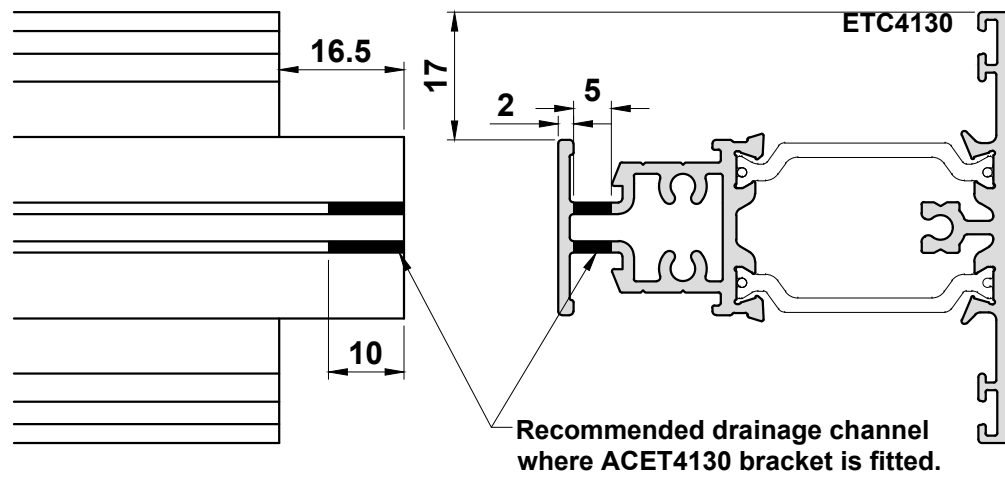
Do Not Scale From This Drawing

Angled Sub Cill

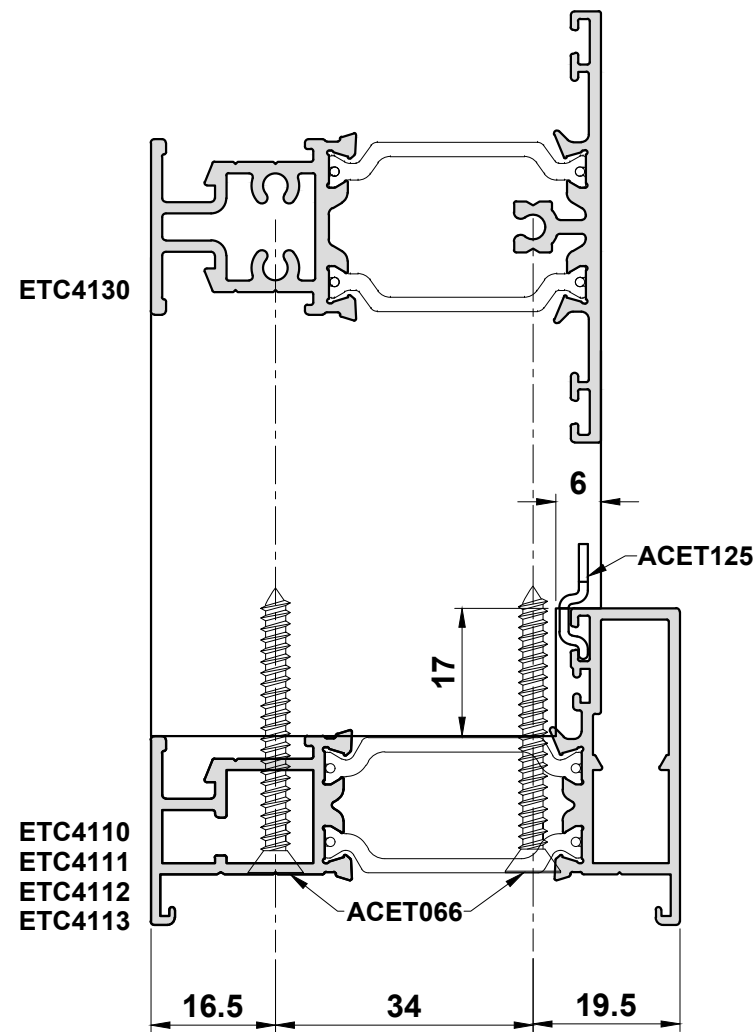
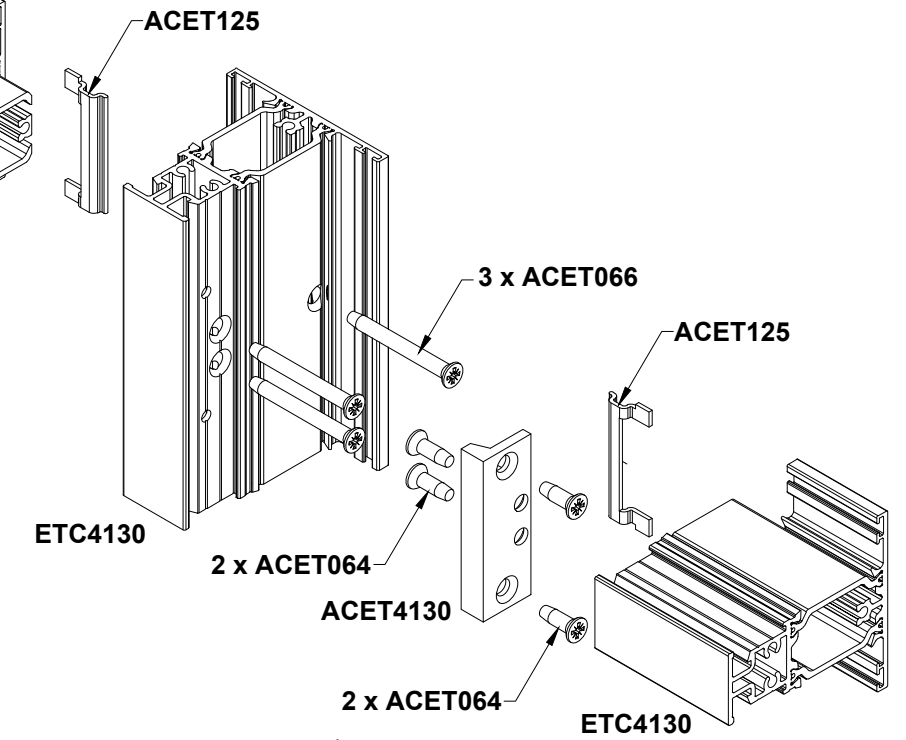
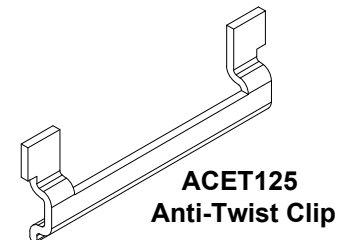
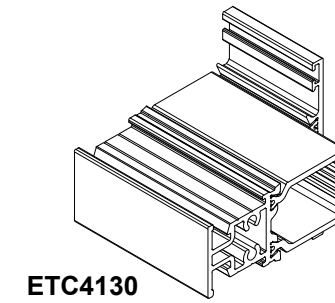
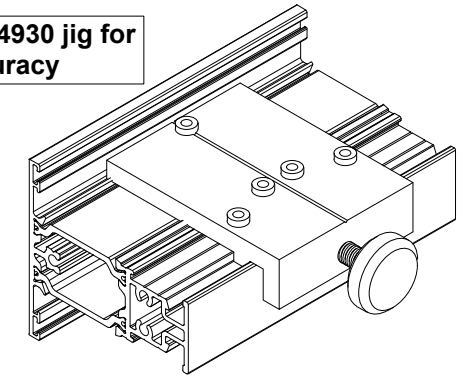


Do Not Scale From This Drawing

ETC4130 Mullion/Transom Detail

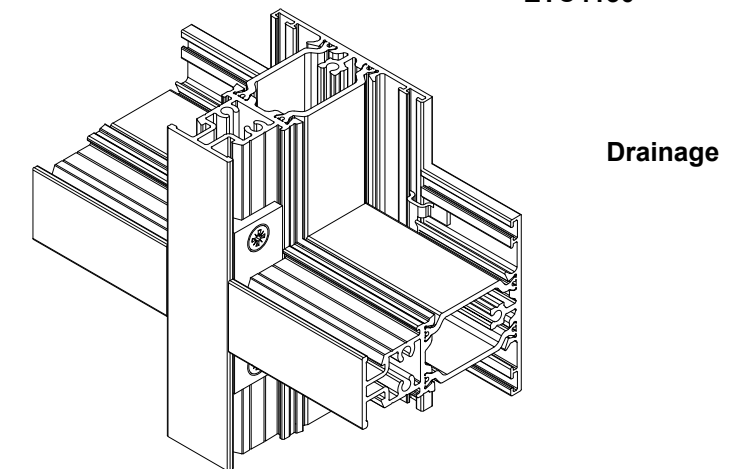


Use ACET4930 jig for accuracy



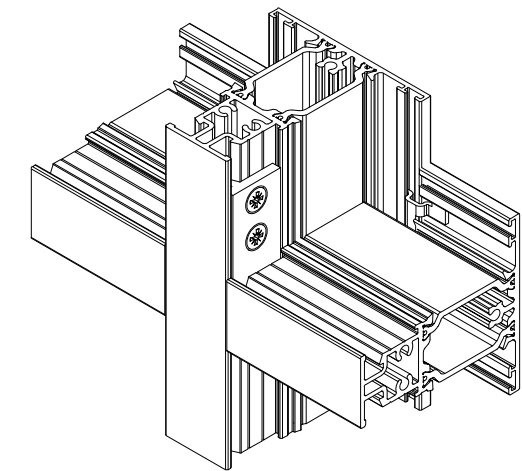
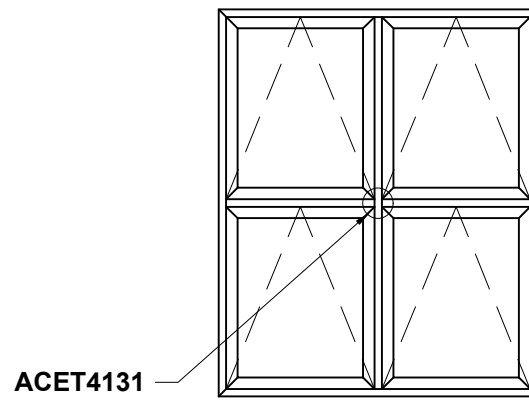
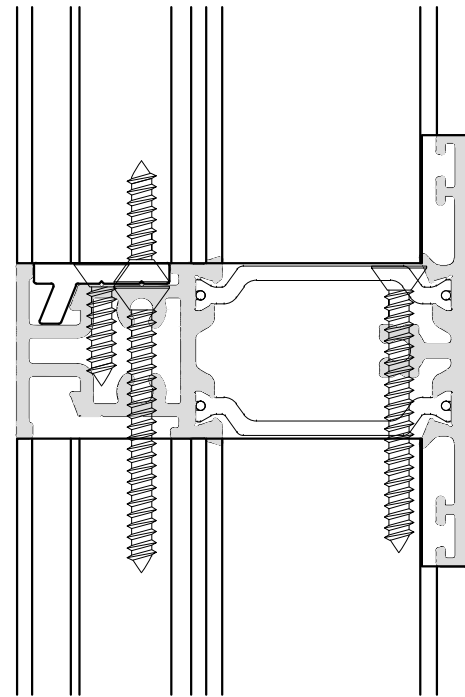
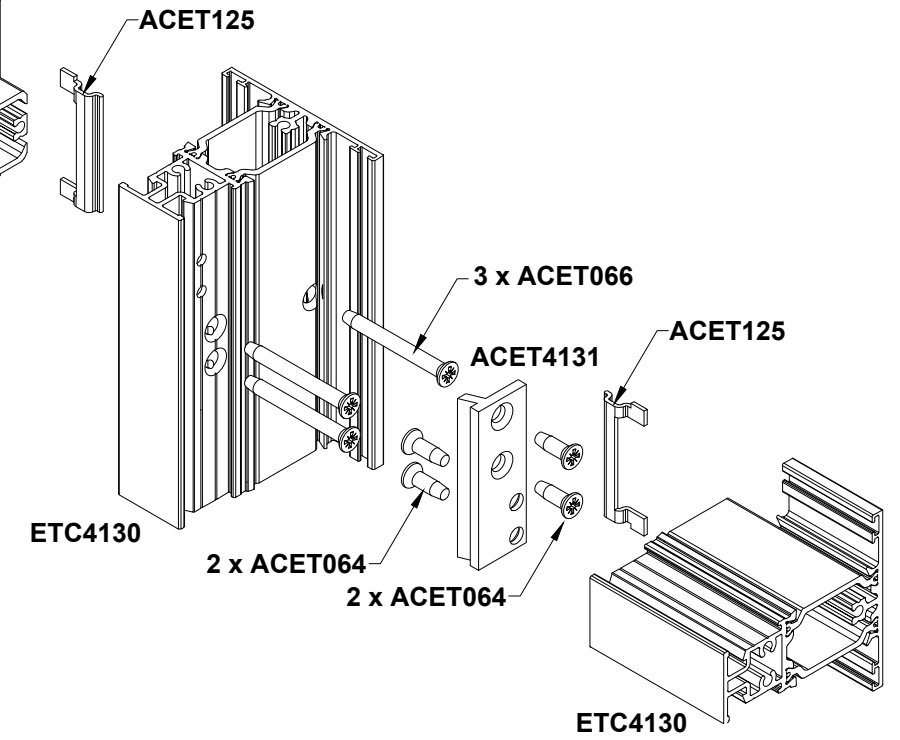
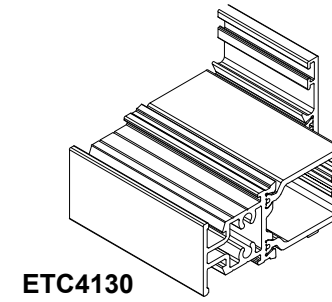
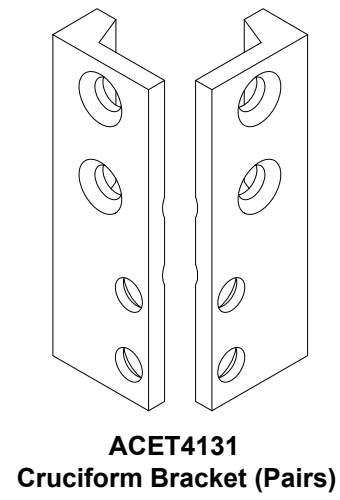
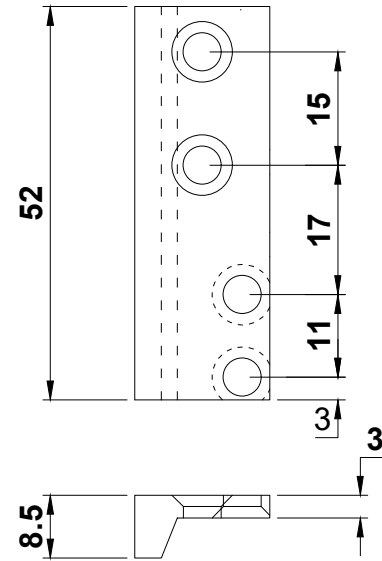
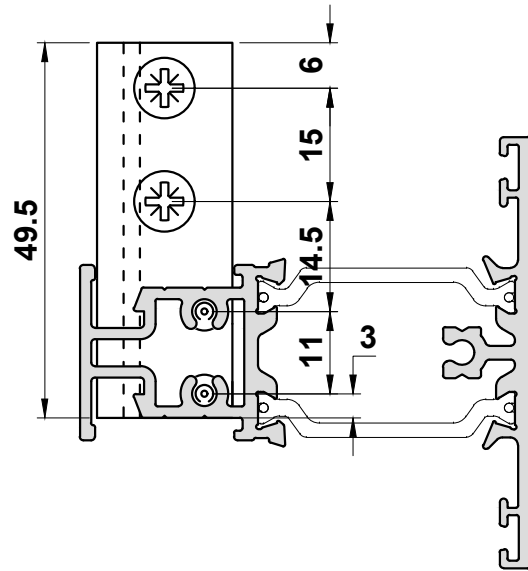
ACET4130
Also consider
ACET4131 - Page E12

Note:
End mill cutters can be ordered through Smart Systems Ltd.
Please contact the Technical Department for an order form.
Standard delivery is 2-3 weeks approx.



Do Not Scale From This Drawing

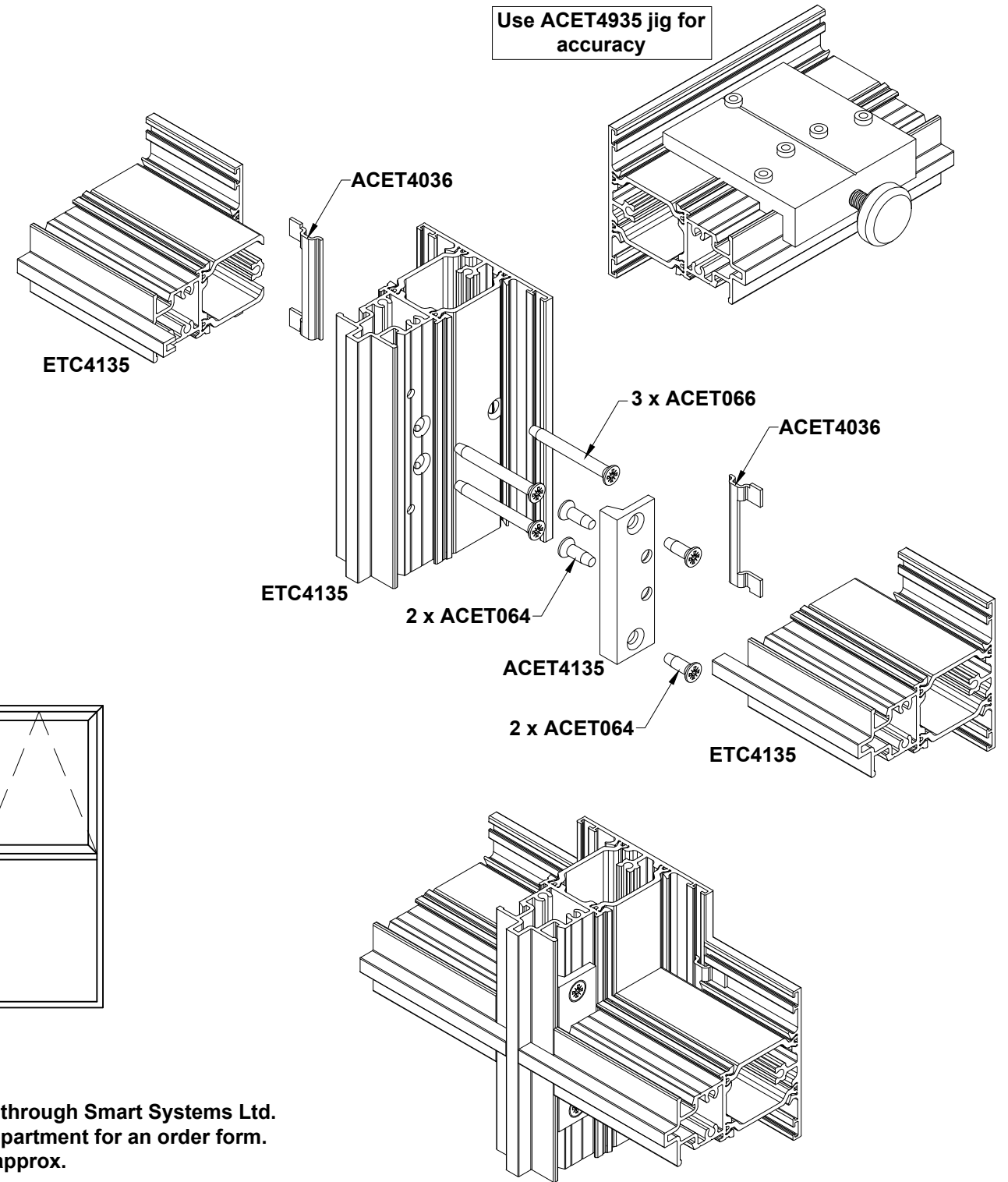
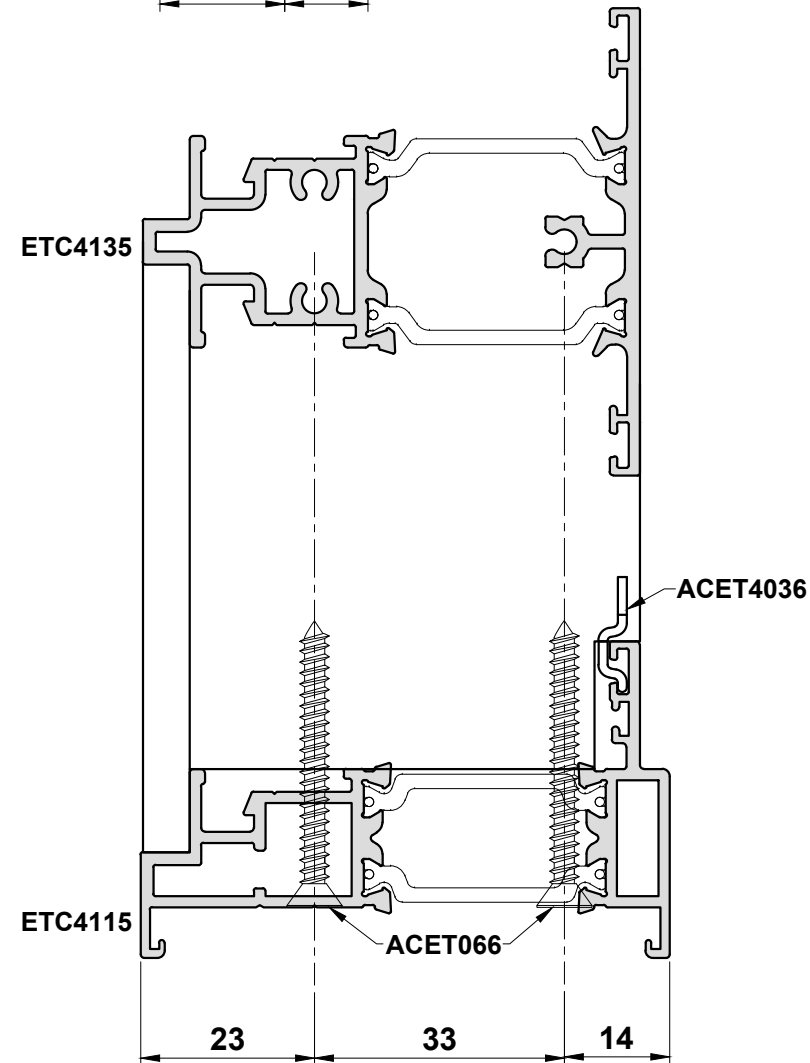
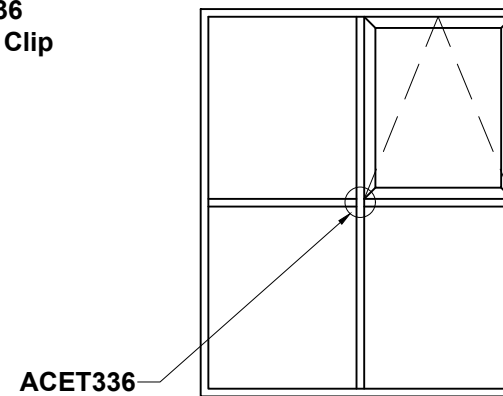
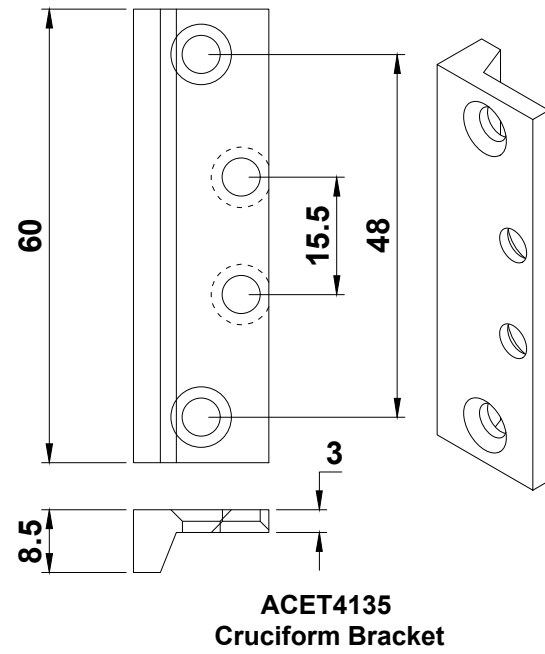
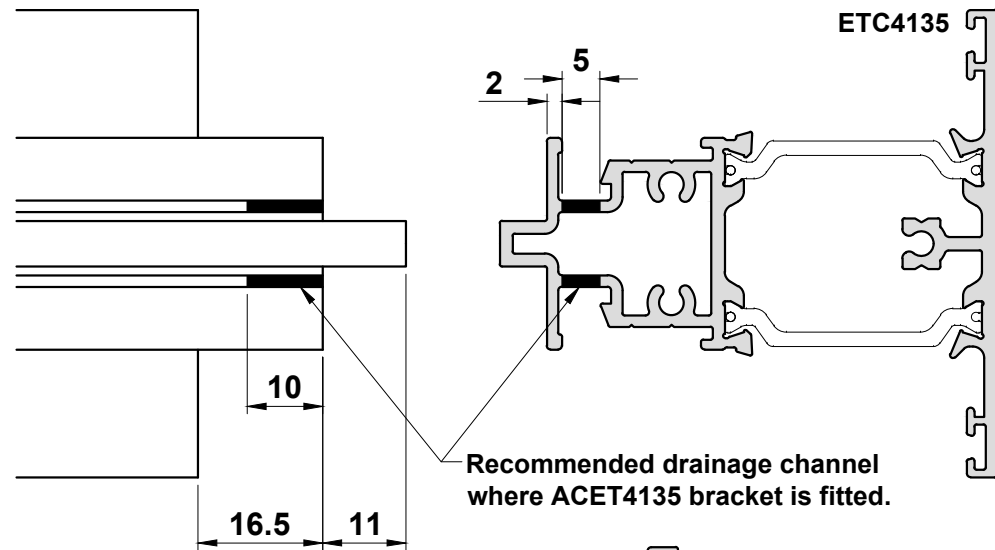
ETC4130 Mullion/Transom Detail



Note:
End mill cutters can be ordered through Smart Systems Ltd.
Please contact the Technical Department for an order form.
Standard delivery is 2-3 weeks approx.

Do Not Scale From This Drawing

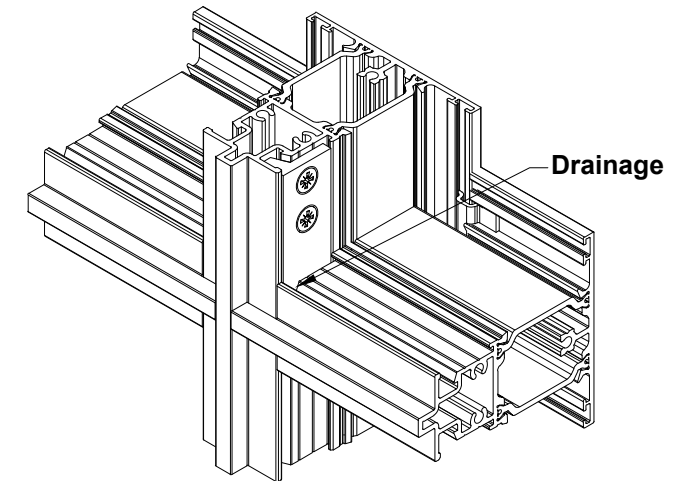
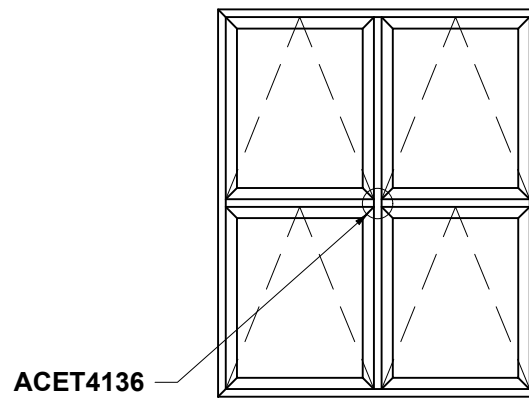
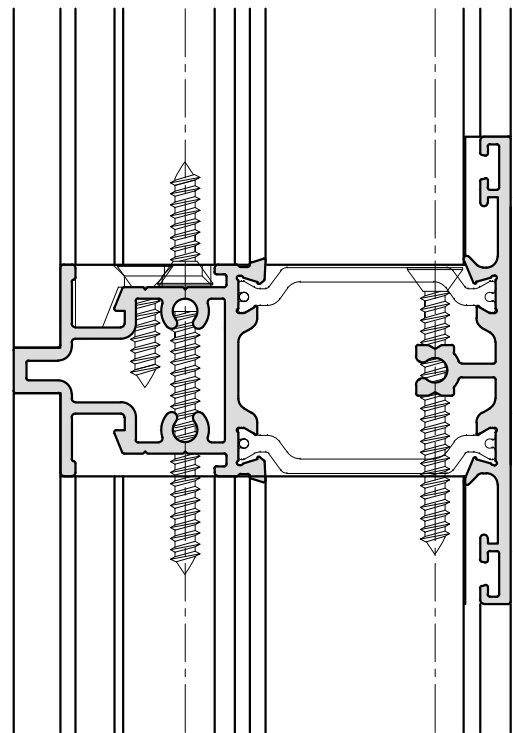
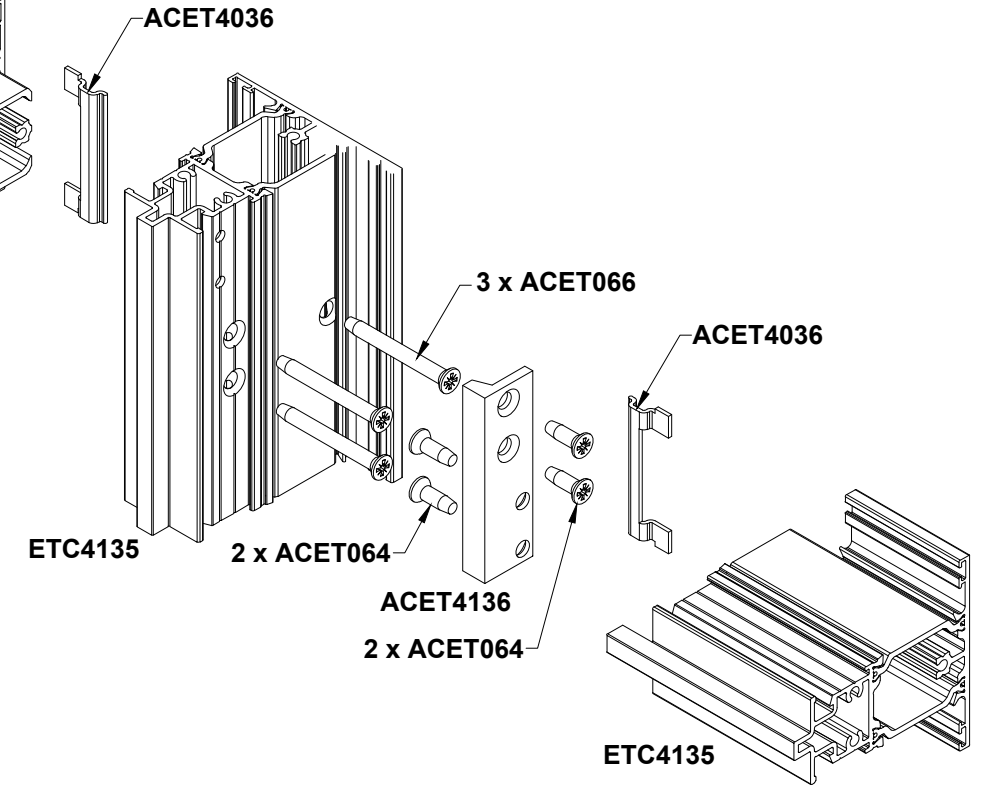
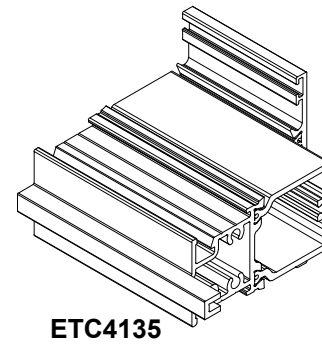
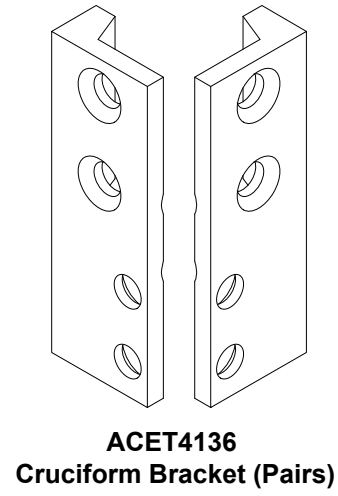
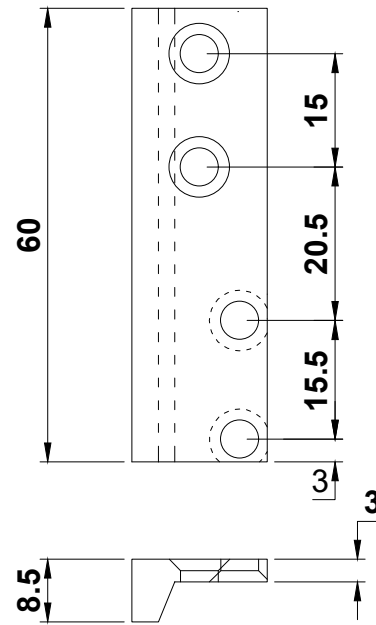
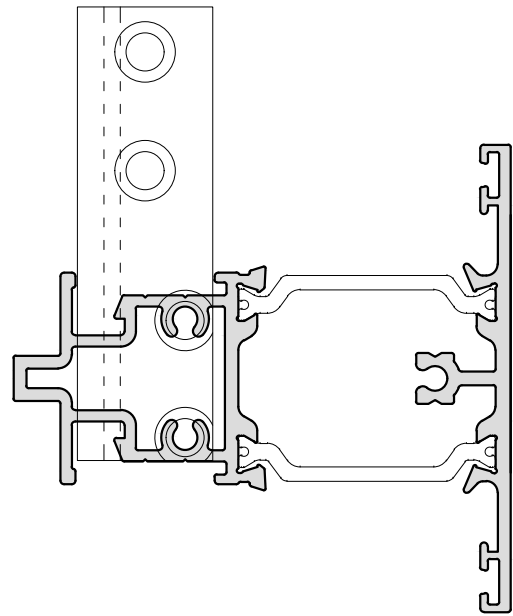
ETC4135 Mullion/Transom Detail



Note:
End mill cutters can be ordered through Smart Systems Ltd.
Please contact the Technical Department for an order form.
Standard delivery is 2-3 weeks approx.

Do Not Scale From This Drawing

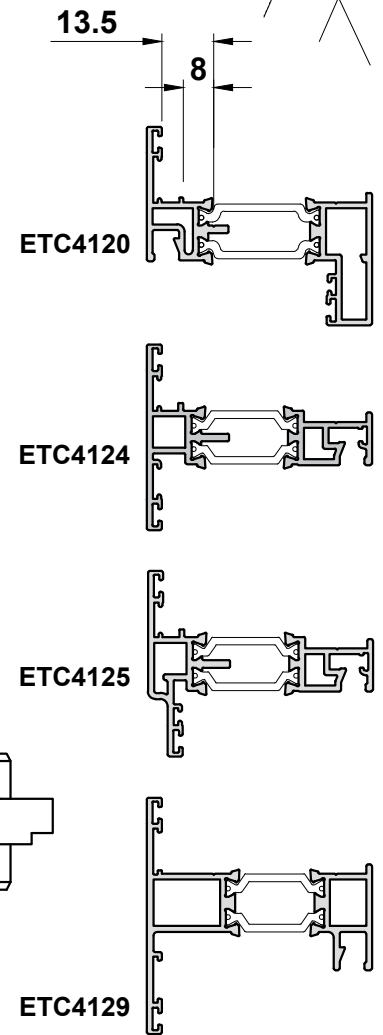
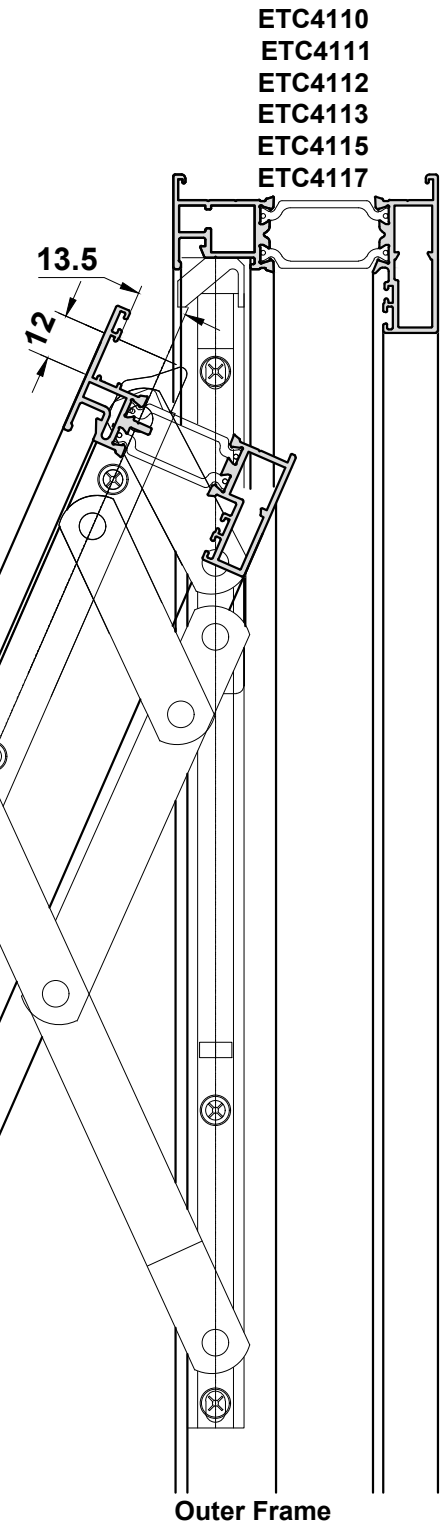
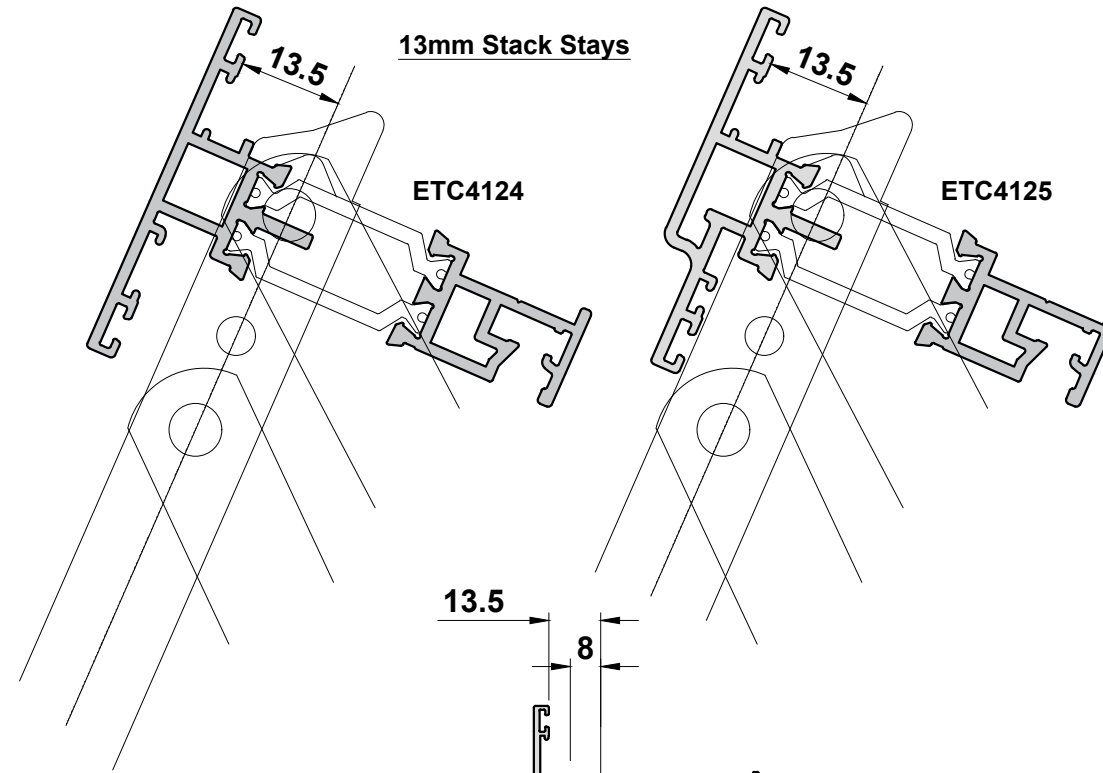
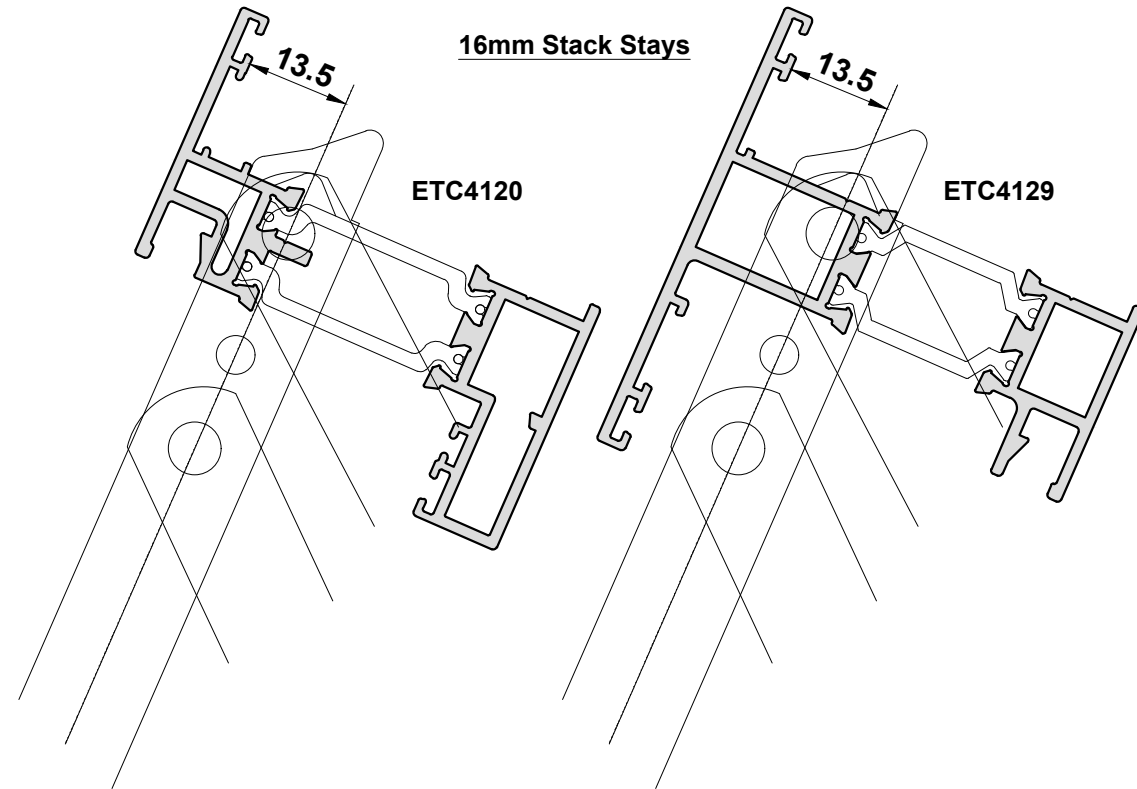
ETC4135 Mullion/Transom Detail



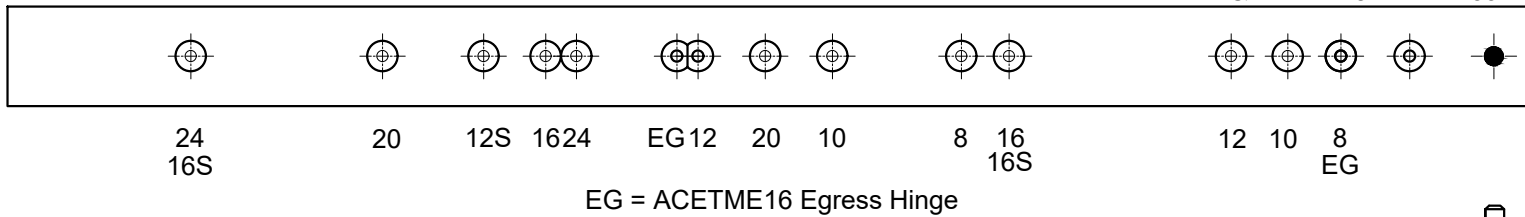
Note:
End mill cutters can be ordered through Smart Systems Ltd.
Please contact the Technical Department for an order form.
Standard delivery is 2-3 weeks approx.

Do Not Scale From This Drawing

Friction Stay Details




ETC4120 & ETC4129 = ACET4904
ETC4124 & ETC4125 = ACET391



EG = ACETME16 Egress Hinge

To ensure accuracy use drill jig .
Numbers indicate stay length in inches, numbers followed by an 'S' are used for side hung stays.

 ACET070 = Recommended Screw

Vent Sizes 450mm or Smaller to be Reduced by 2mm

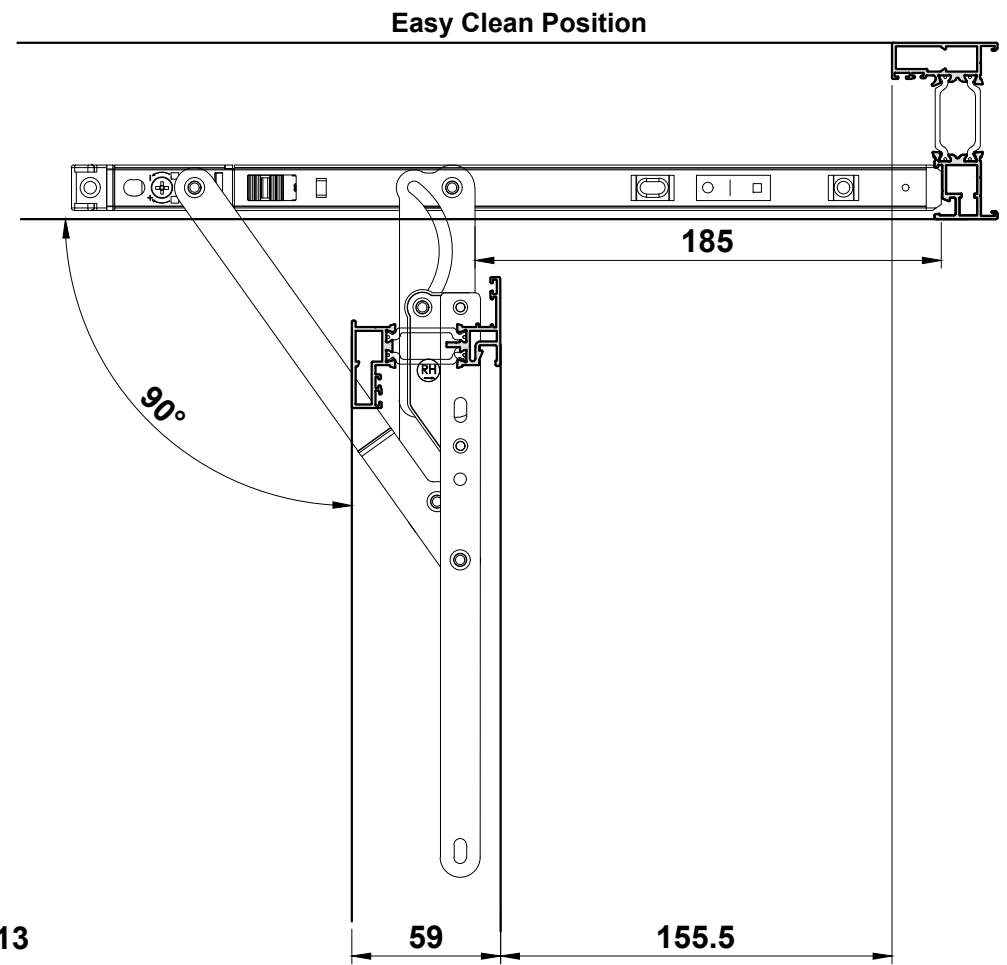
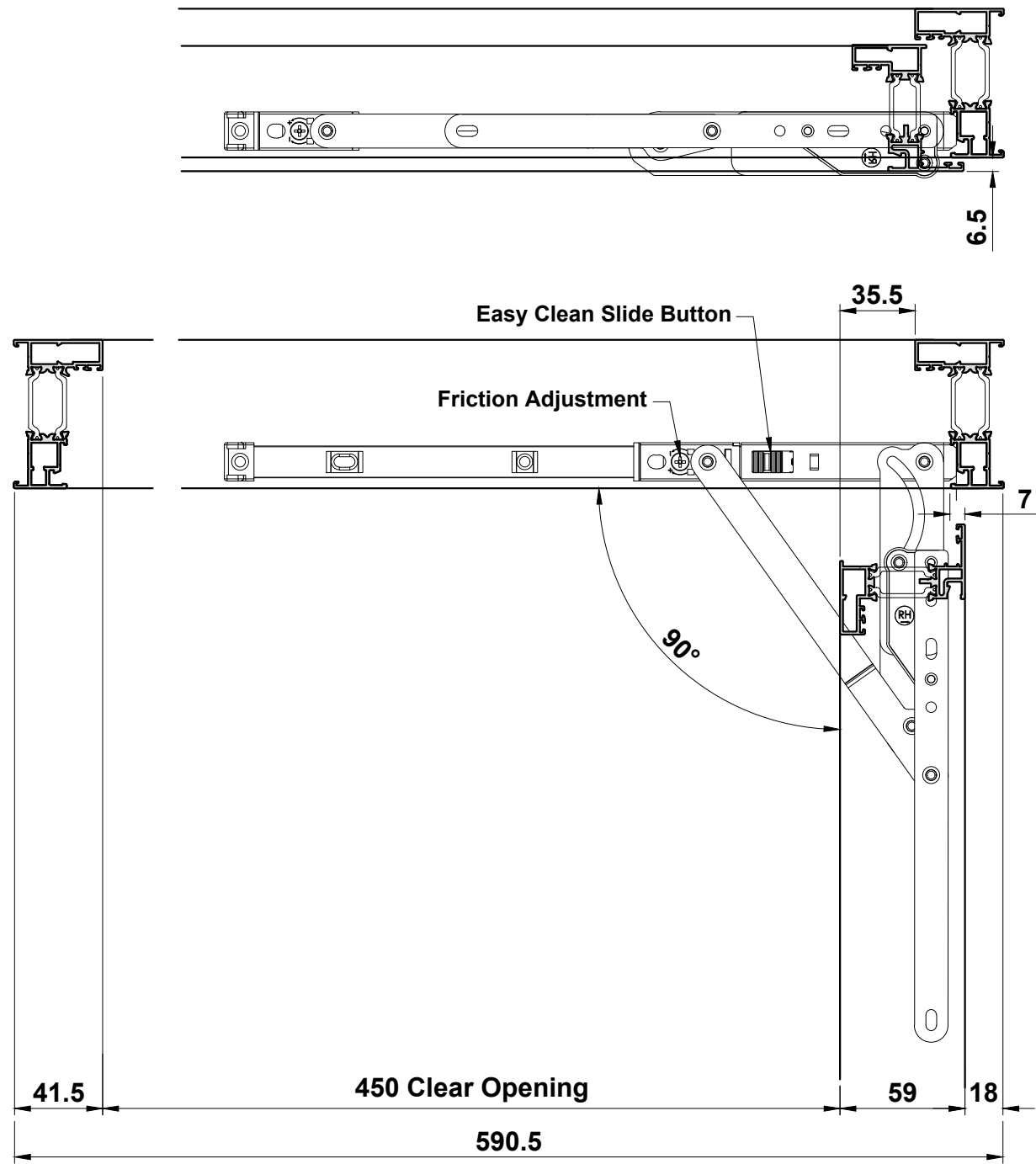
Do Not Scale From This Drawing

Egress Hinge Details

Example Opening Detail

The benefits of these hinges are:

- True 90° opening angle
- Achieves minimum fire escape requirement on smaller windows
- Can be moved into easy clean position, with automatic reset on closing
- Superior carrying weight (40kg max)
- The 345mm length replaces the current 305mm & 406mm hinges
- Tested to BS EN1670 and exceeded Grade 5 for ultimate corrosion resistance
- Tested to EN1191 over 25,000 cycles under 40kg.



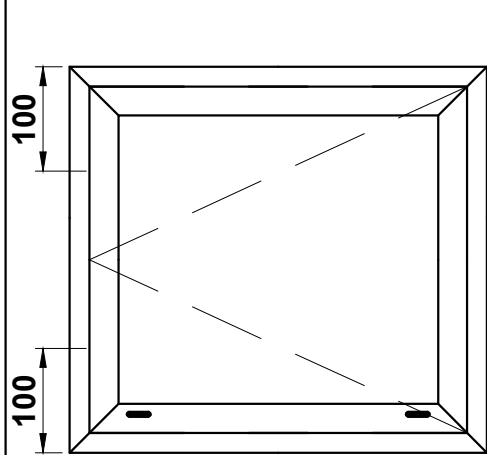
For further information regarding clear openings, please see the Smart Systems' White Paper Document B

ACETME16 & ACETME13 Egress Hinges

Side Hung	Sashes	Jig	Max. Vent	Width		Typical Height
			Weight (kgs)	Minimum	Maximum	
ACETME13	ETC4124 & ETC4125	ACETME93	40	365	865	-
ACETME16	ETC4120 & ETC4129	ACETME96				

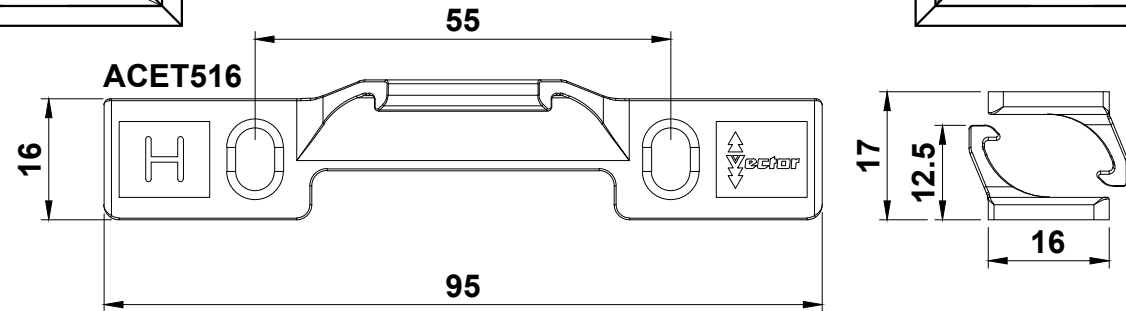
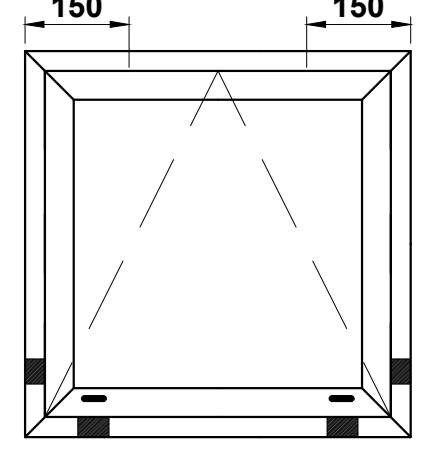
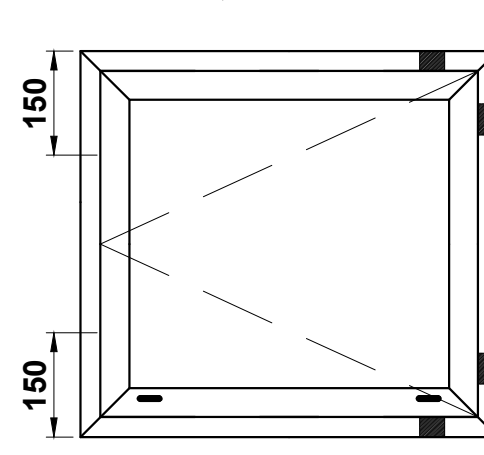
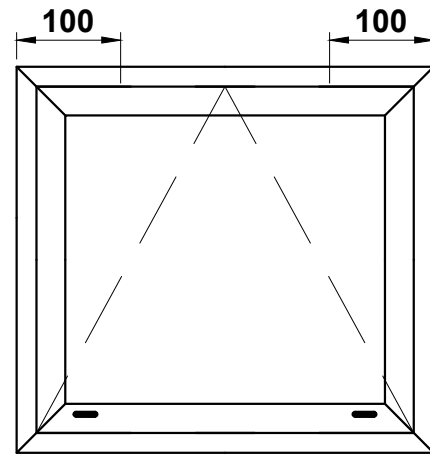
Do Not Scale From This Drawing

Security Hinge Protectors & Pull-In Blocks



Please Note:

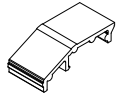
- 2 pairs per opening vent to be fitted to hinged side of window
- Each pair must be fitted with the hook centre within 100mm of each hinge



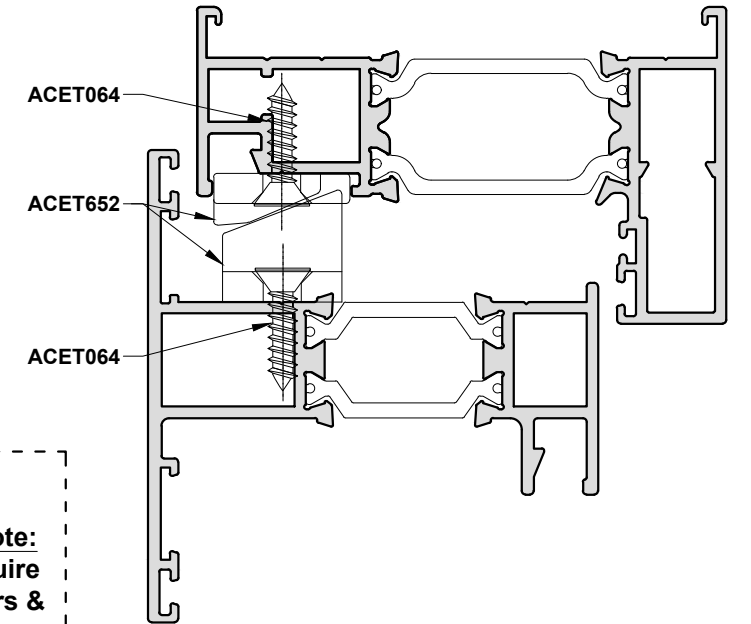
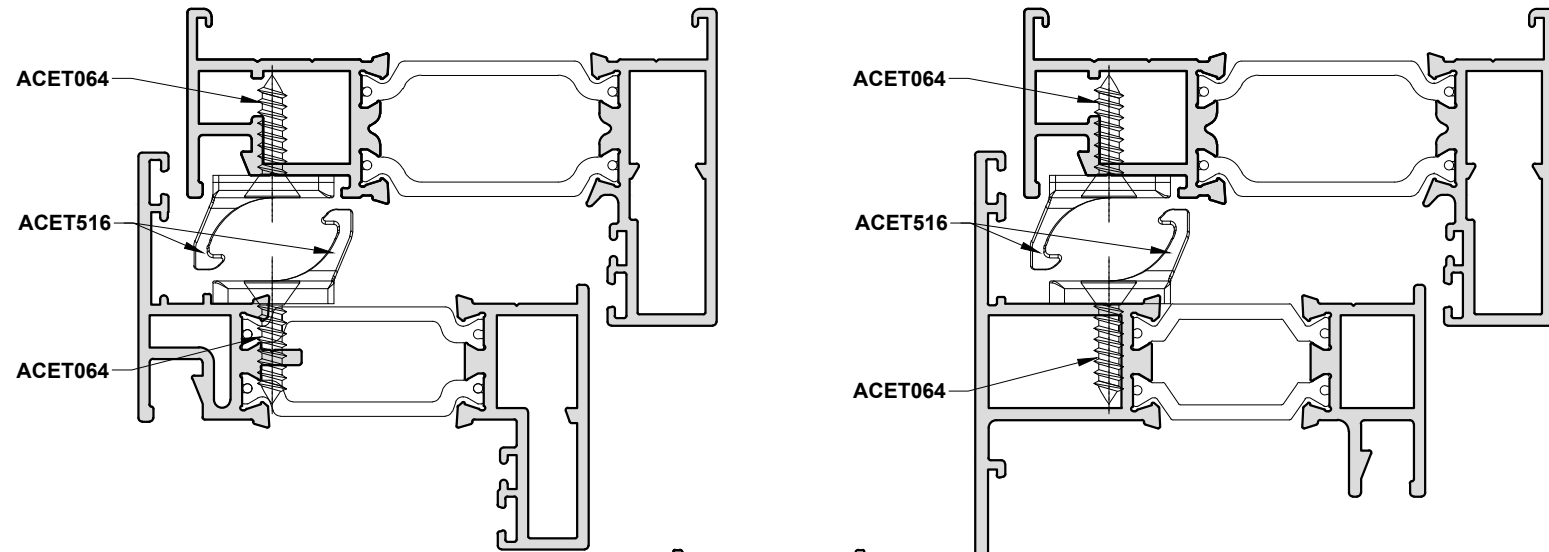
Please Note:

- 2 pairs per opening vent to be fitted to hinged side of window
- Each pair must be fitted with the wedge centre within 150mm of each hinge and in the centre of the window when sash height or width is greater than 800mm.
- When used with ACET516 and security takes priority, install ACET652 centre within 200mm of hinge.

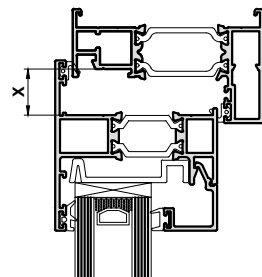
ACET4180



Please note that for fitting each sash, we recommend using 4 x ACET4180, as shown in the images above.



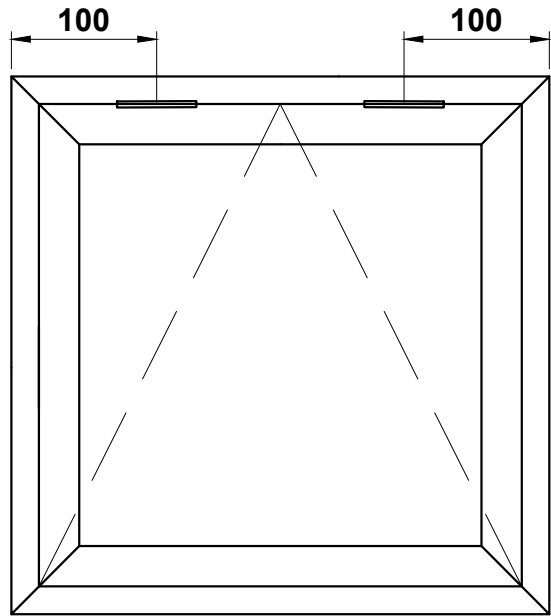
Pull In Block		
Sash	Pull In Block	'X'
ETC4120	ACET652	17
ETC4124	ACET352	14.5
ETC4129	ACET652	17



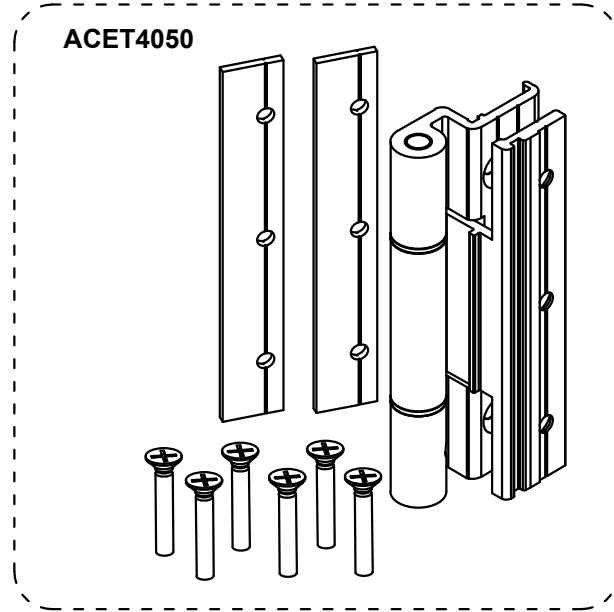
**ETC4124
ETC4125**

Important Fabrication Note:
ETC4124 & ETC4125 require ACET513 Hinge Protectors & ACET352 Pull-In Blocks.

ACET4050 Hinge Details

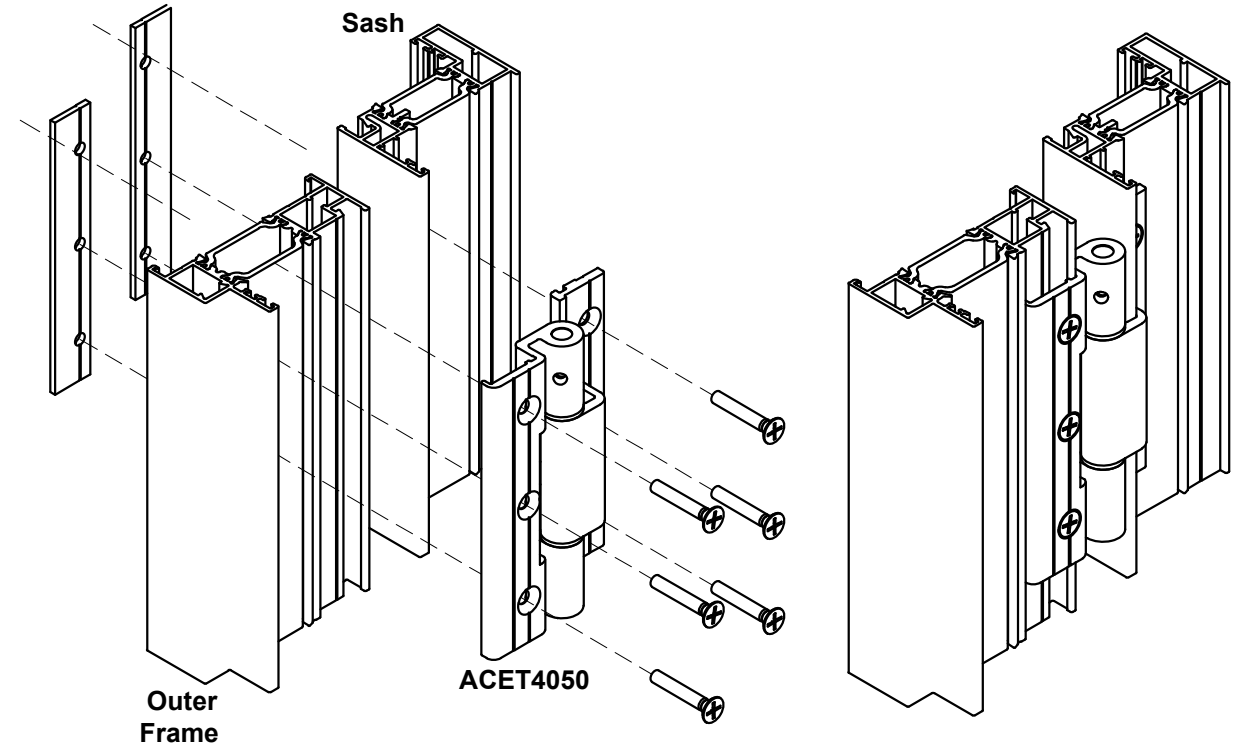


Please note: ACET4050 Butt Hinge is not covered by the Kitemark.



ACET4050

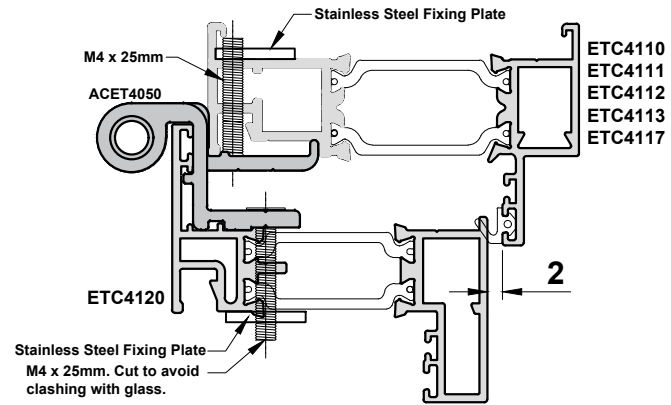
**Top Hung Max. 50kg
Side Hung Max. 40kg**



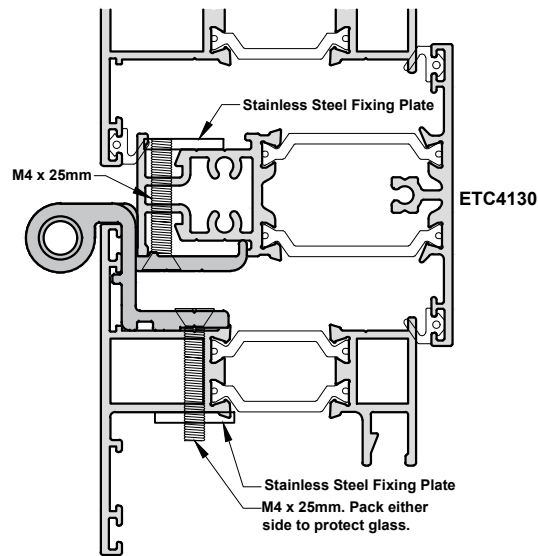
Outer Frame

ACET4050

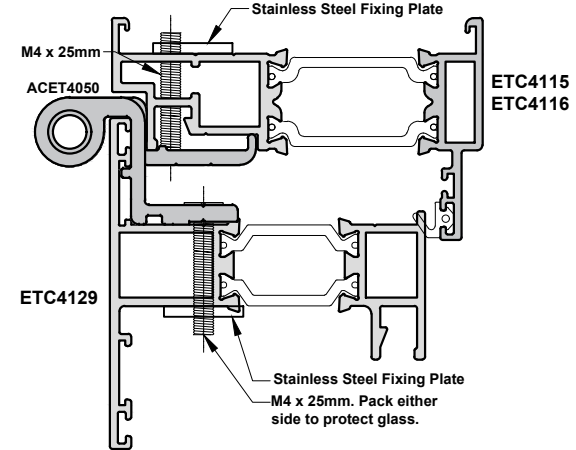
Sash



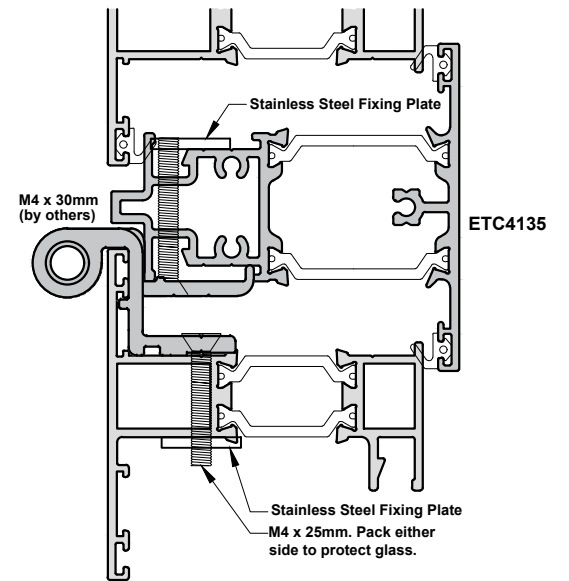
ETC4110
ETC4111
ETC4112
ETC4113
ETC4117



ETC4130



ETC4115
ETC4116

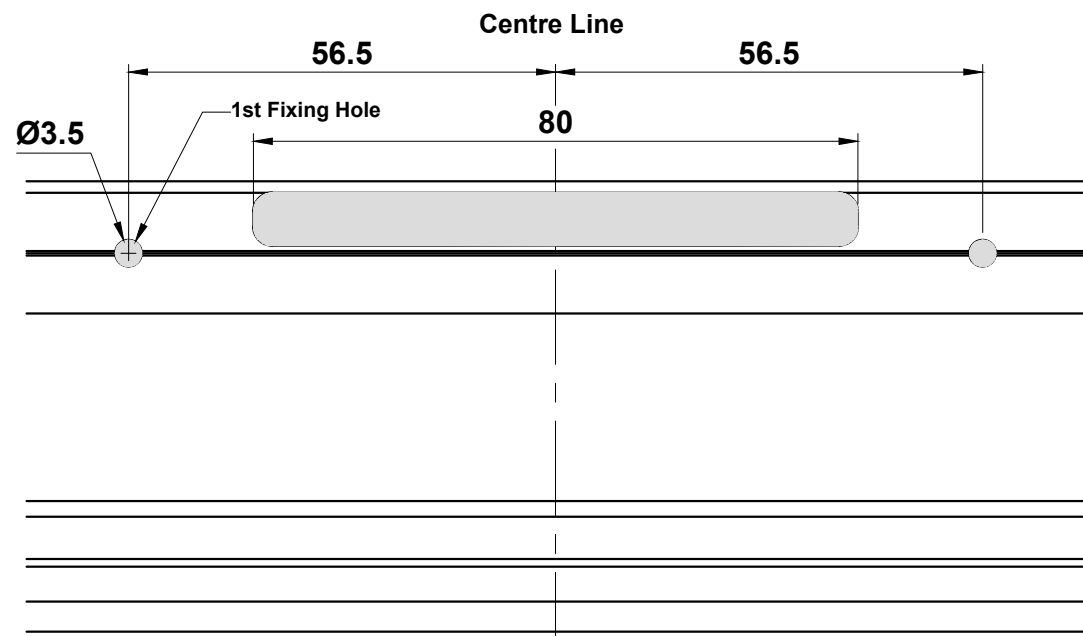


ETC4135

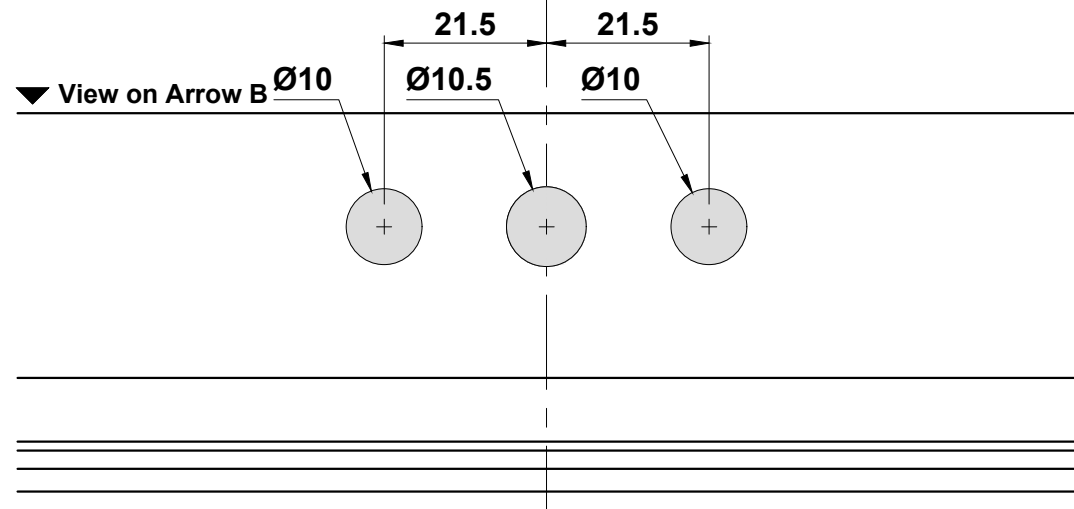
**Important note:
ACET4050 Butt Hinge is not compatible with ETC4124 & ETC4125**

Do Not Scale From This Drawing

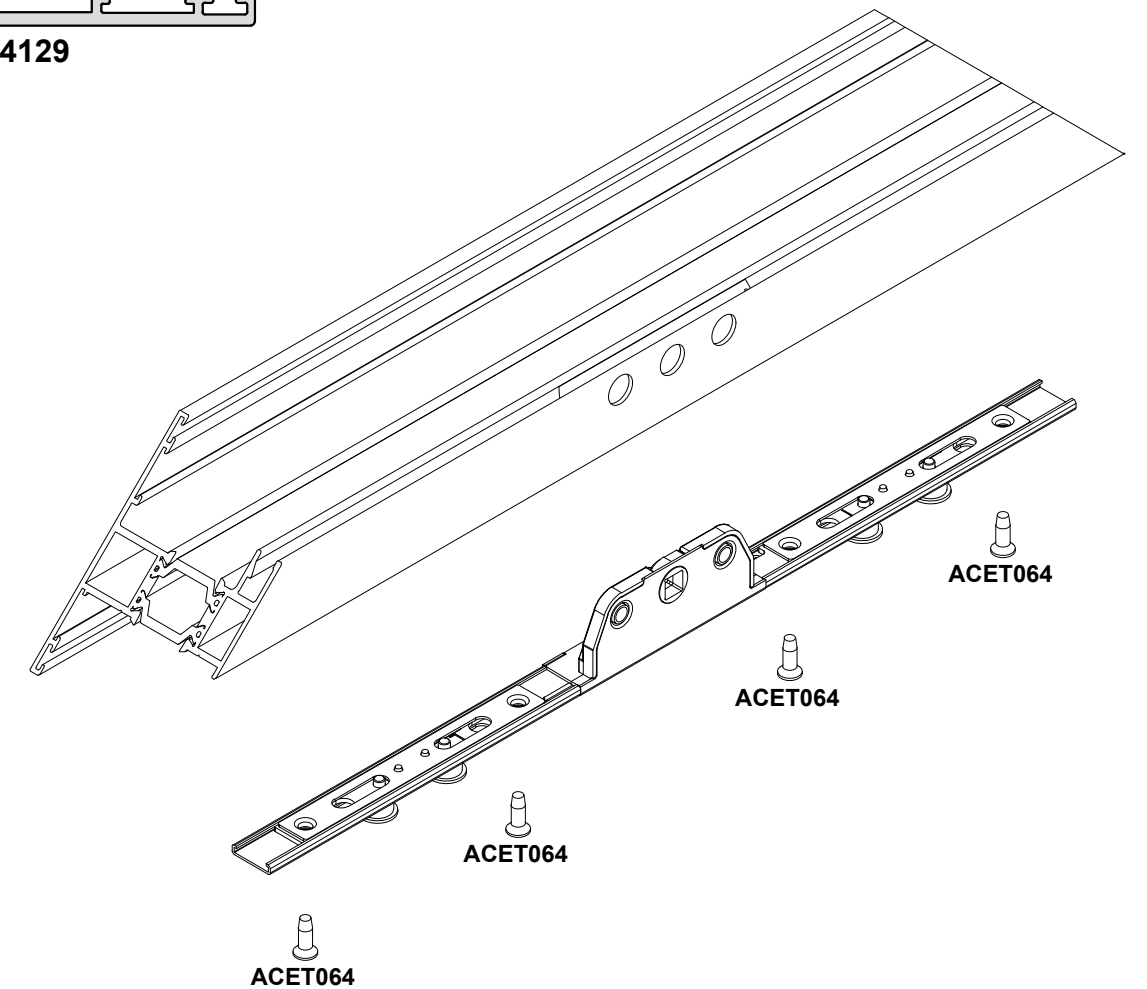
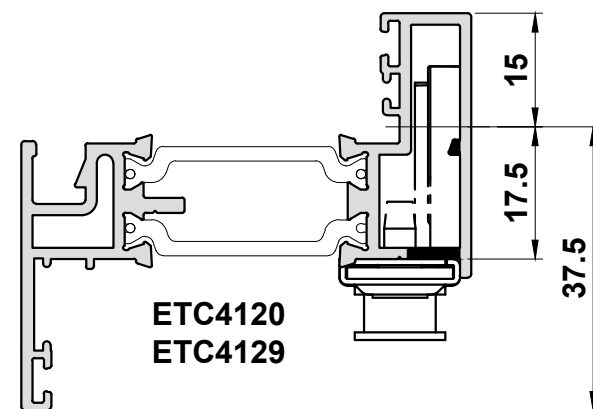
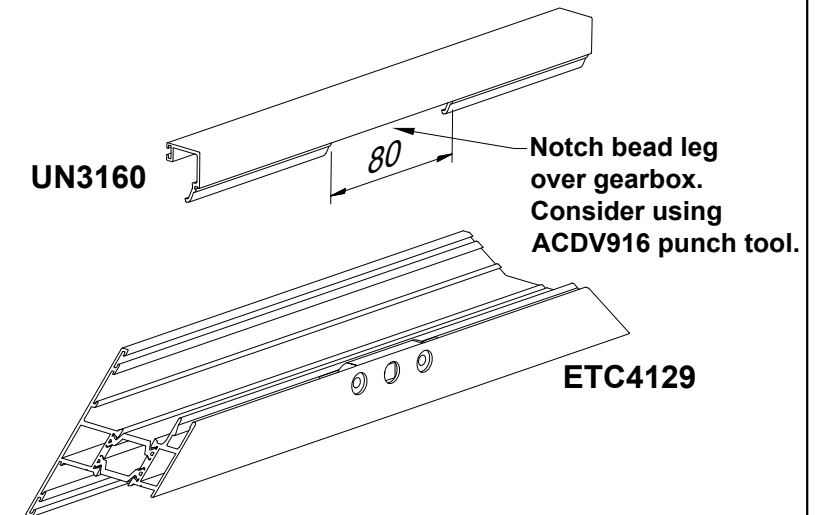
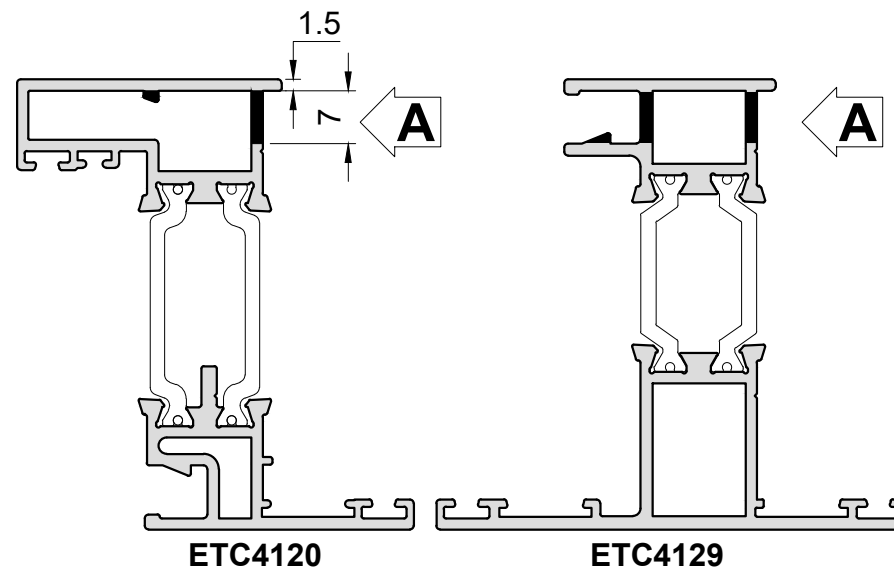
Espag Locking Prep Detail



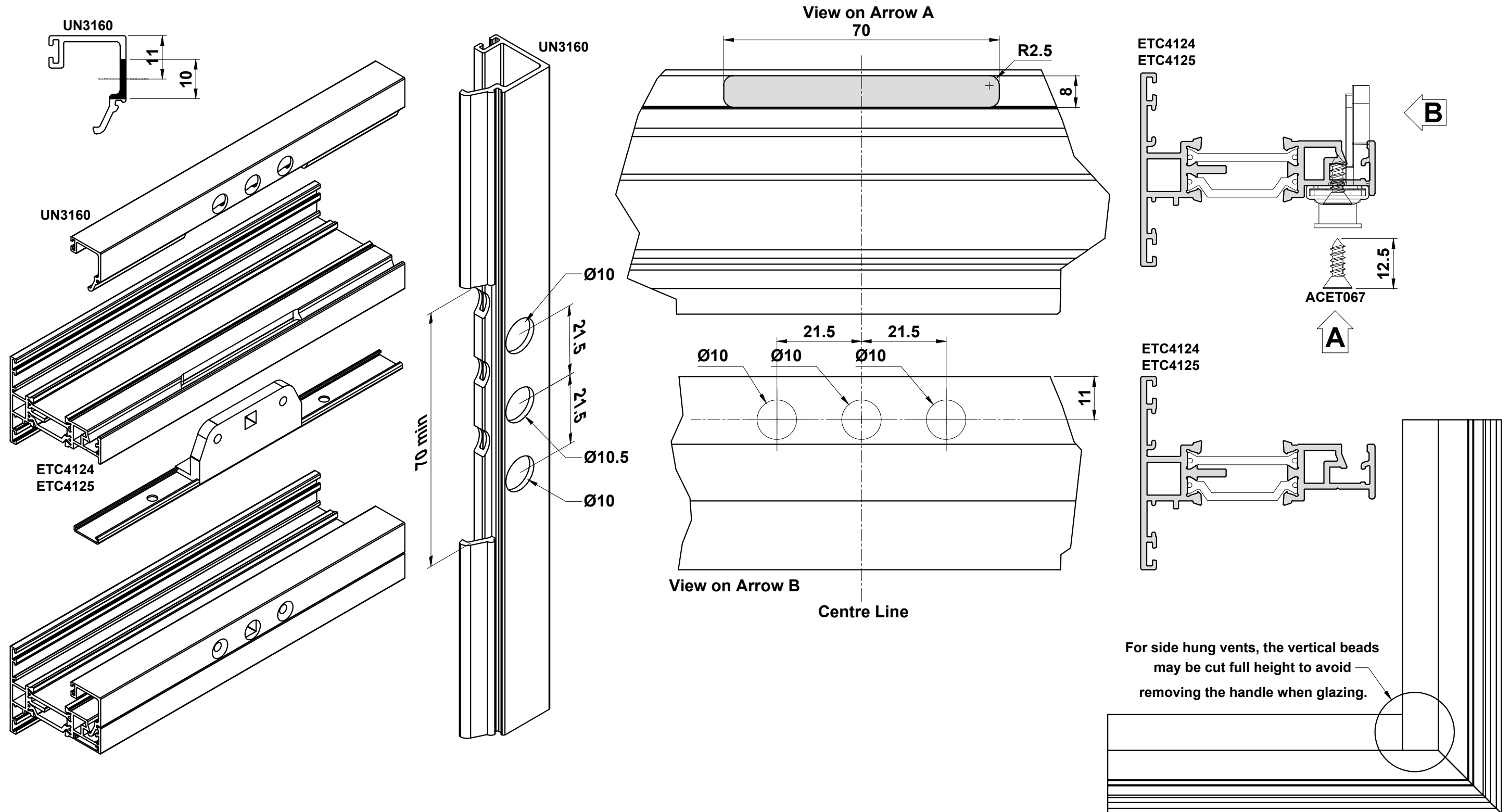
▲ View on Arrow A



▼ View on Arrow B

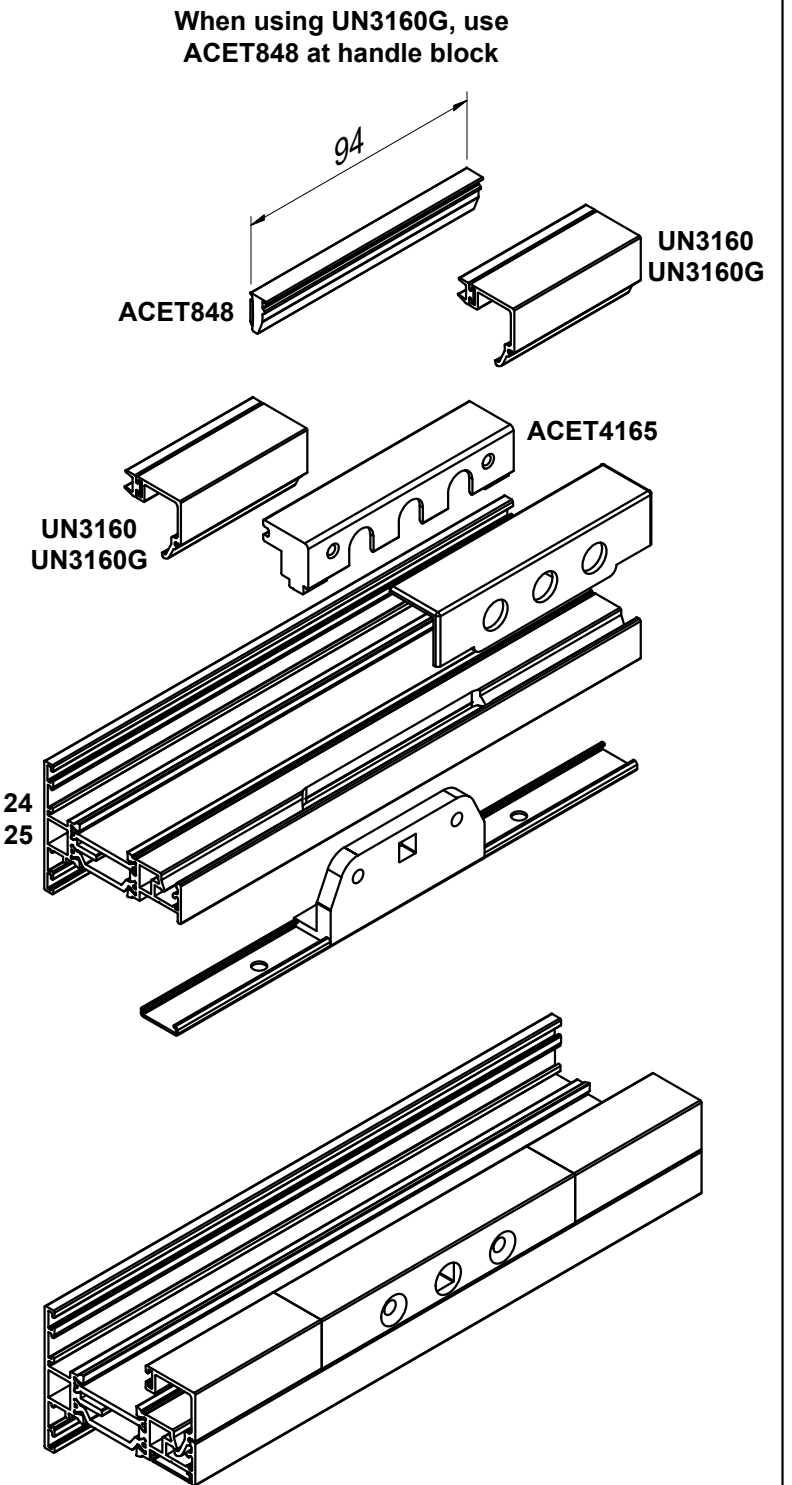
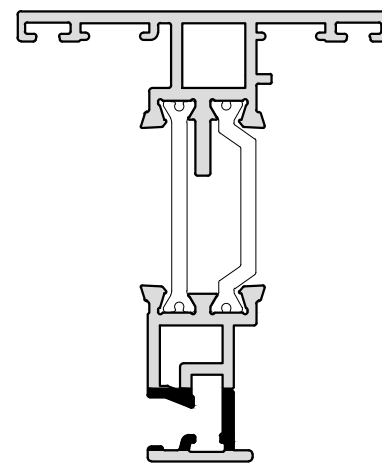
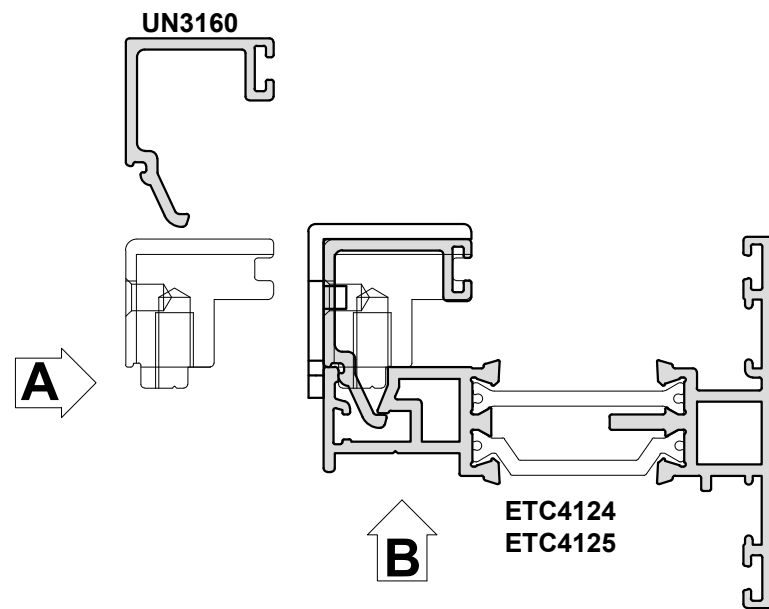
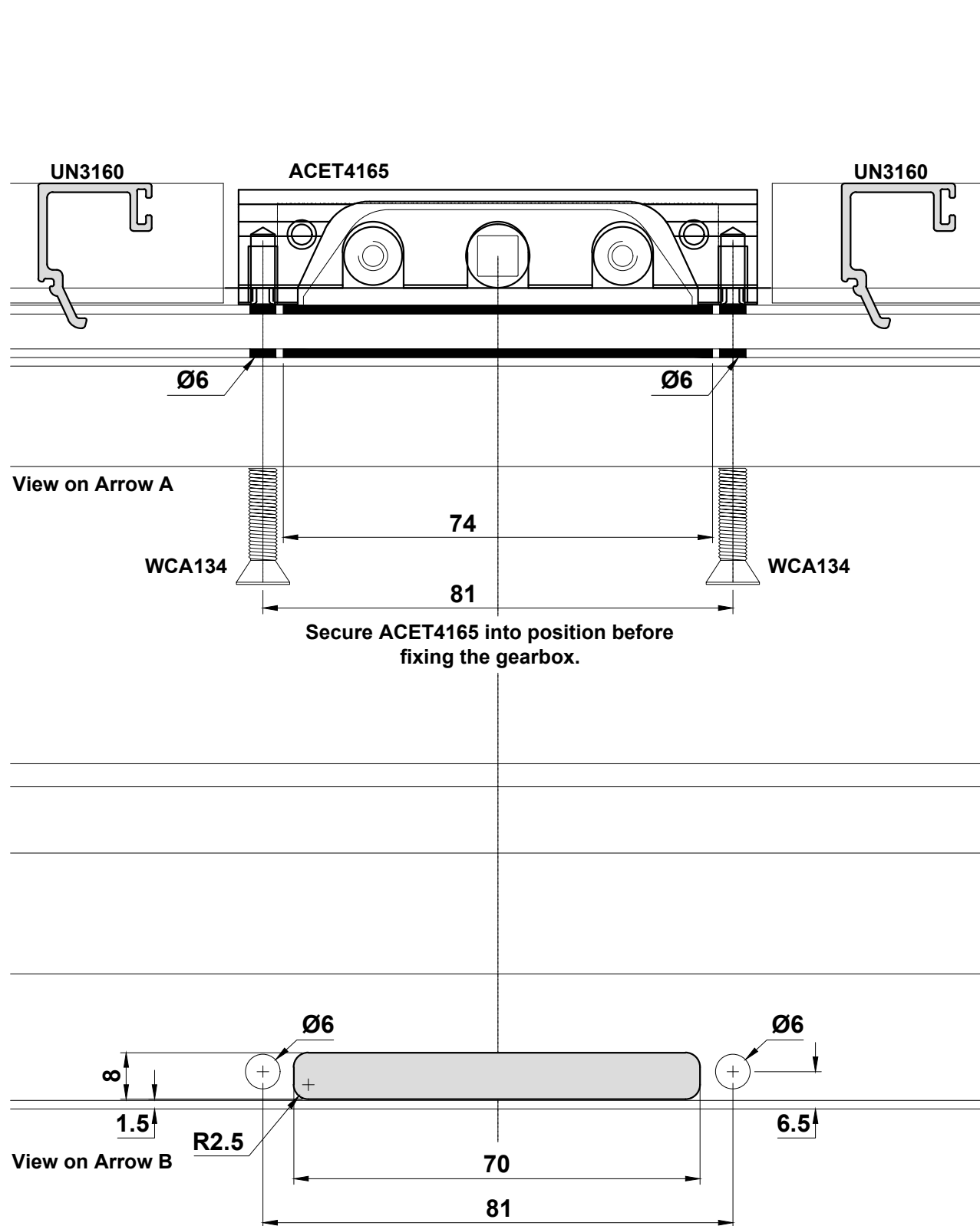


Lock & Handle Machining

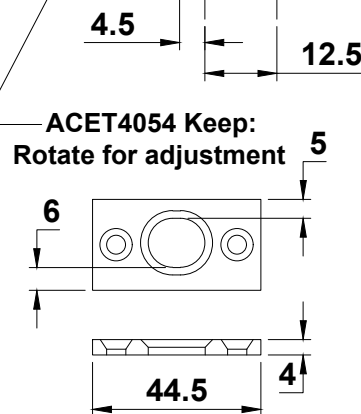
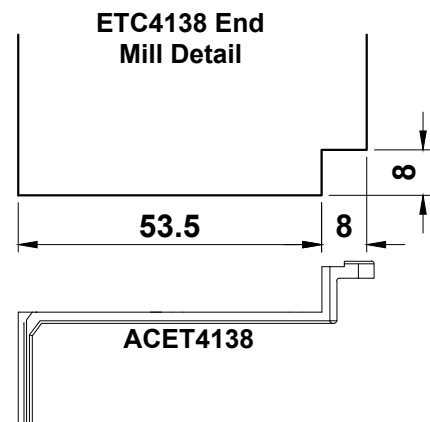
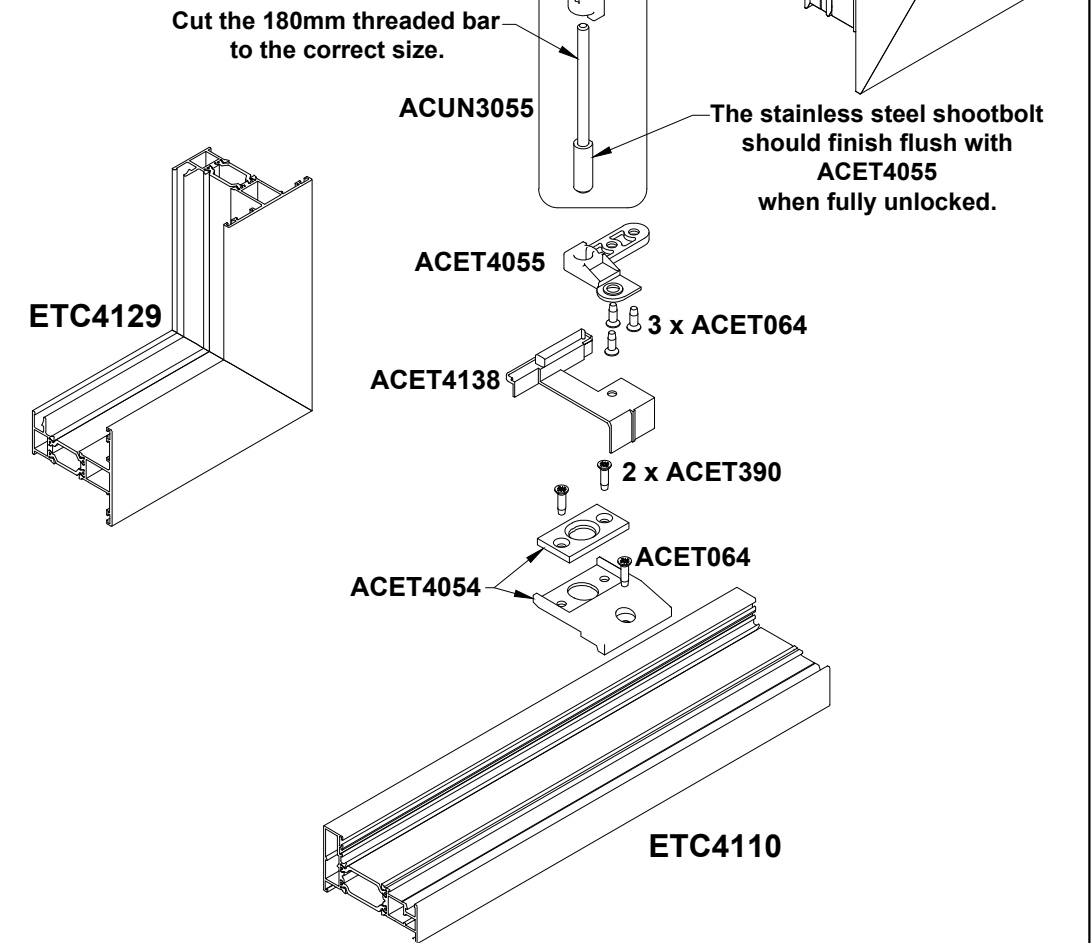
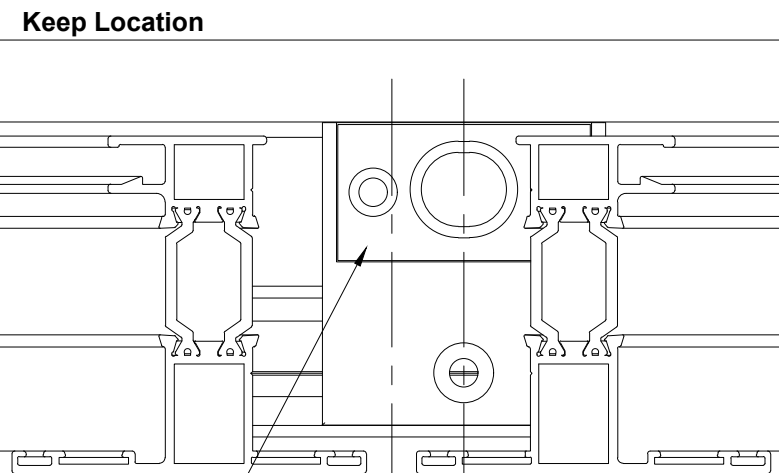
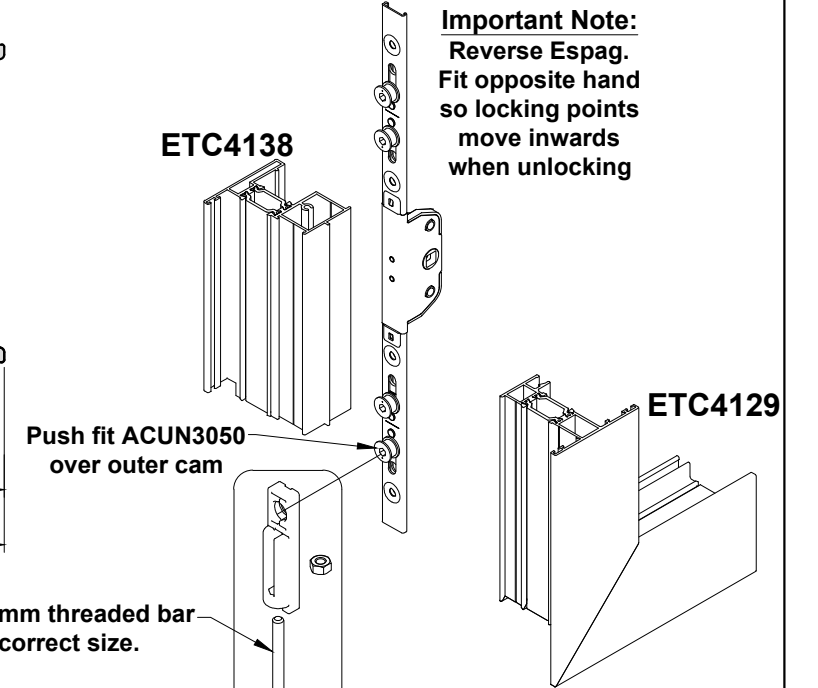
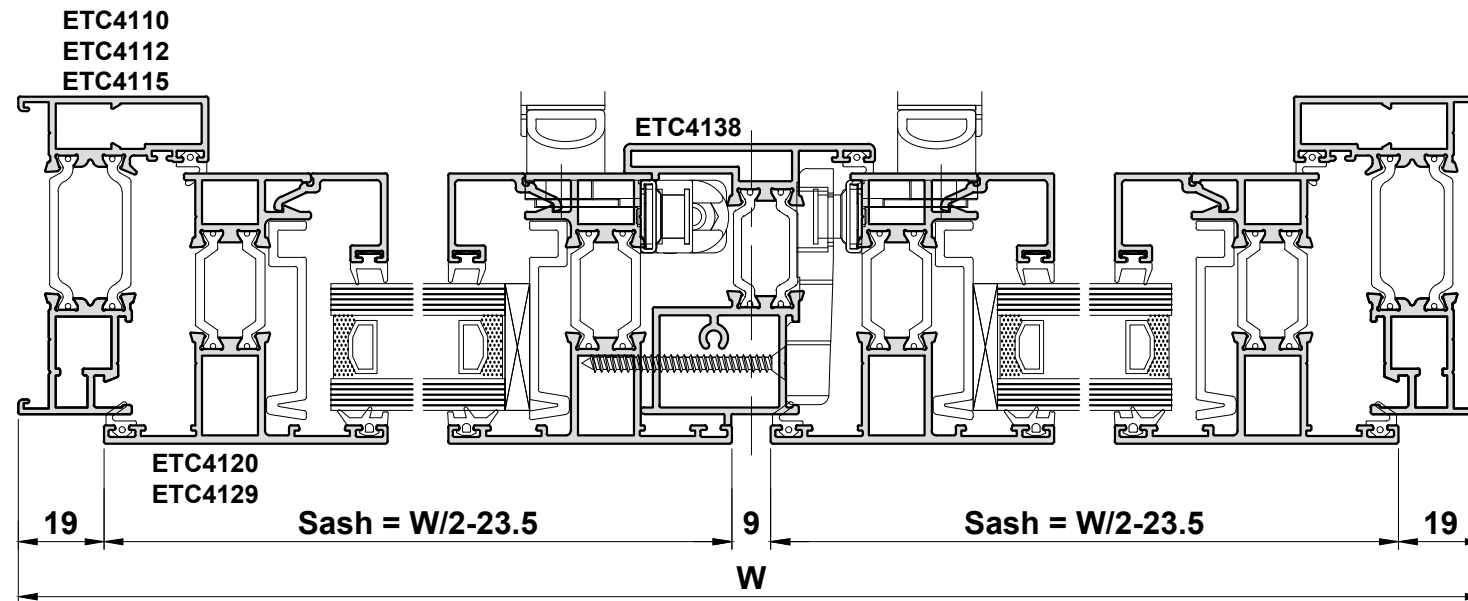
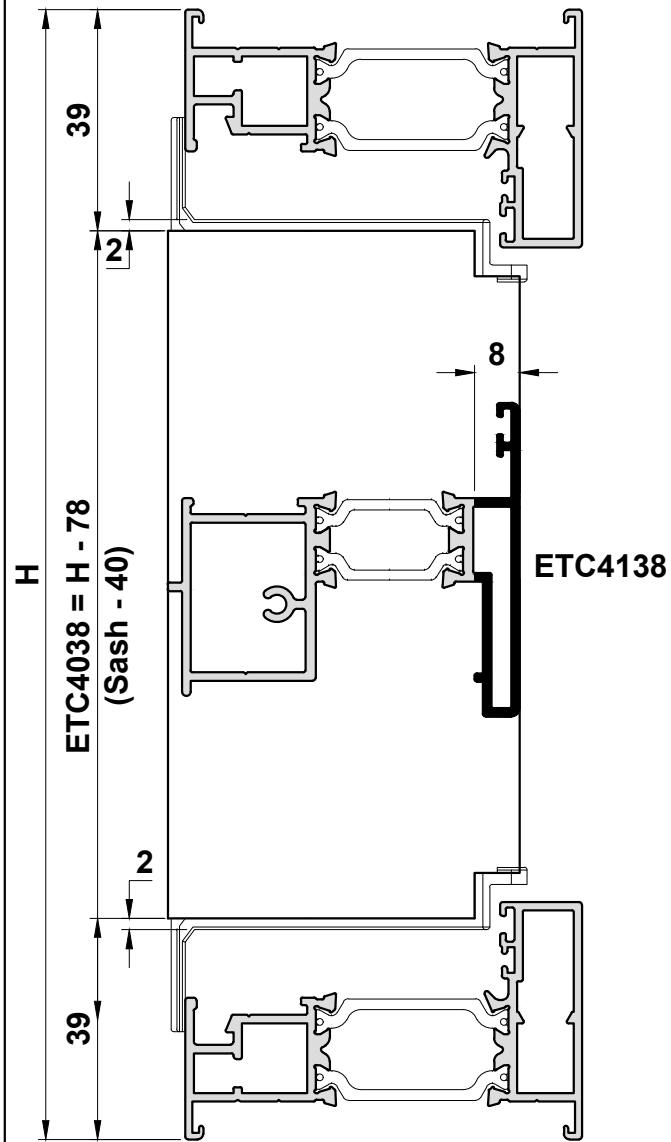


Do Not Scale From This Drawing

Lock & Handle Machining

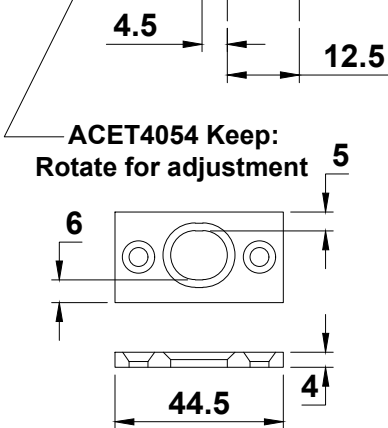
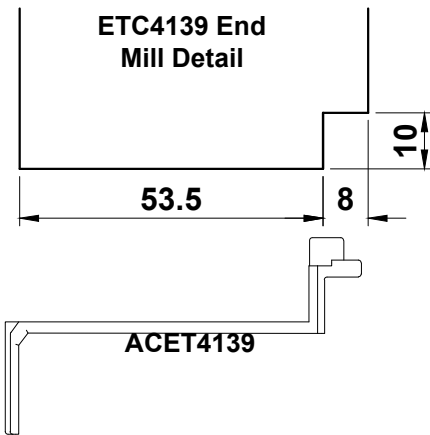
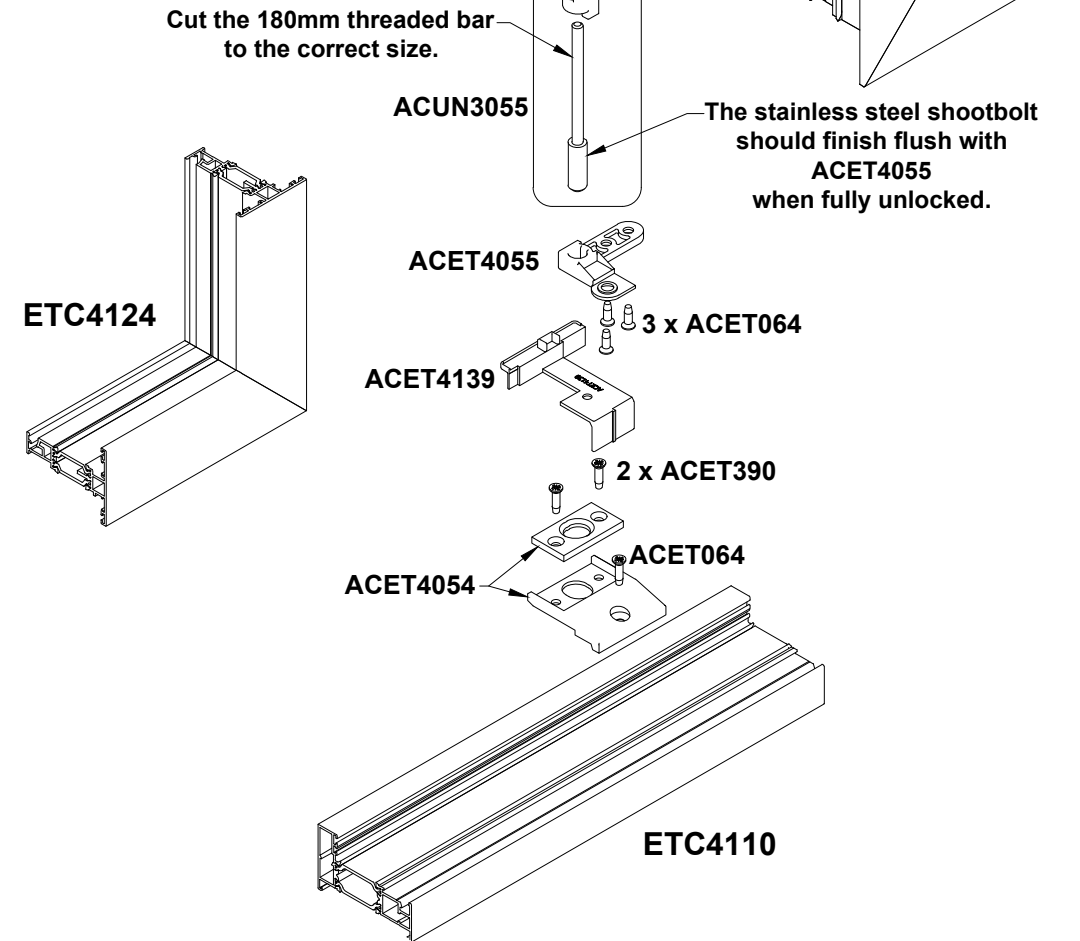
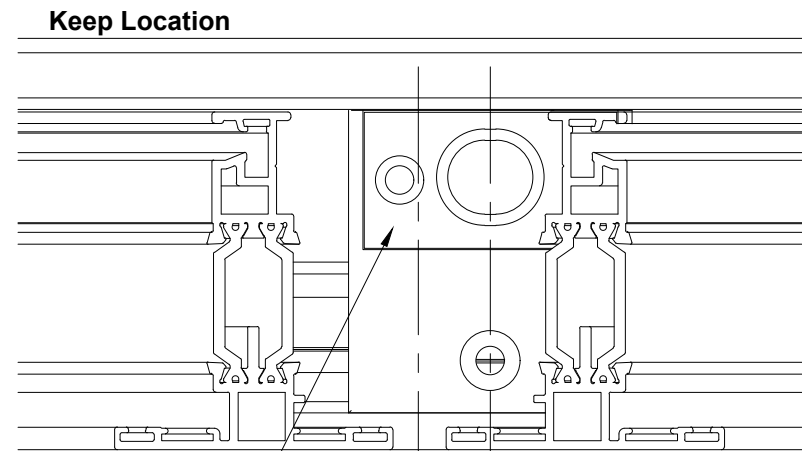
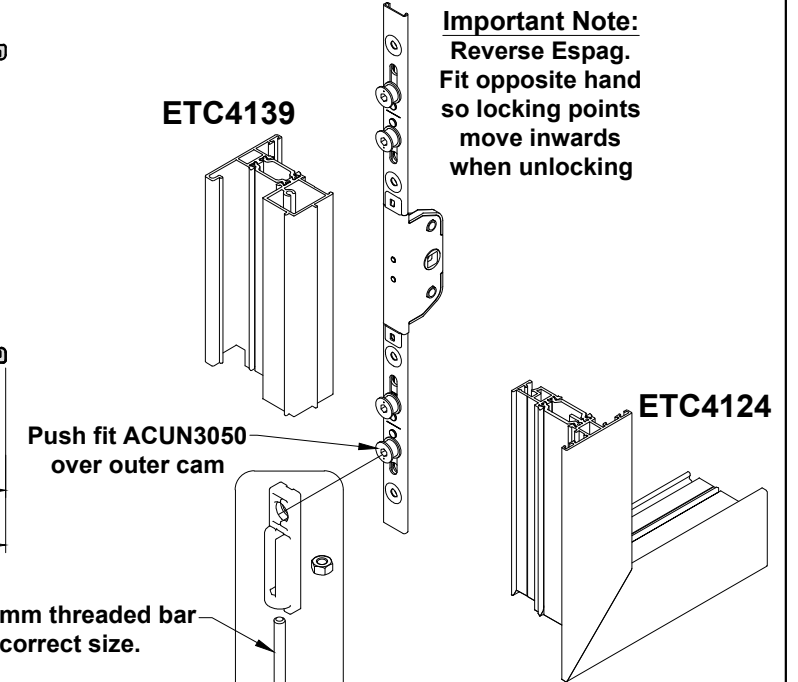
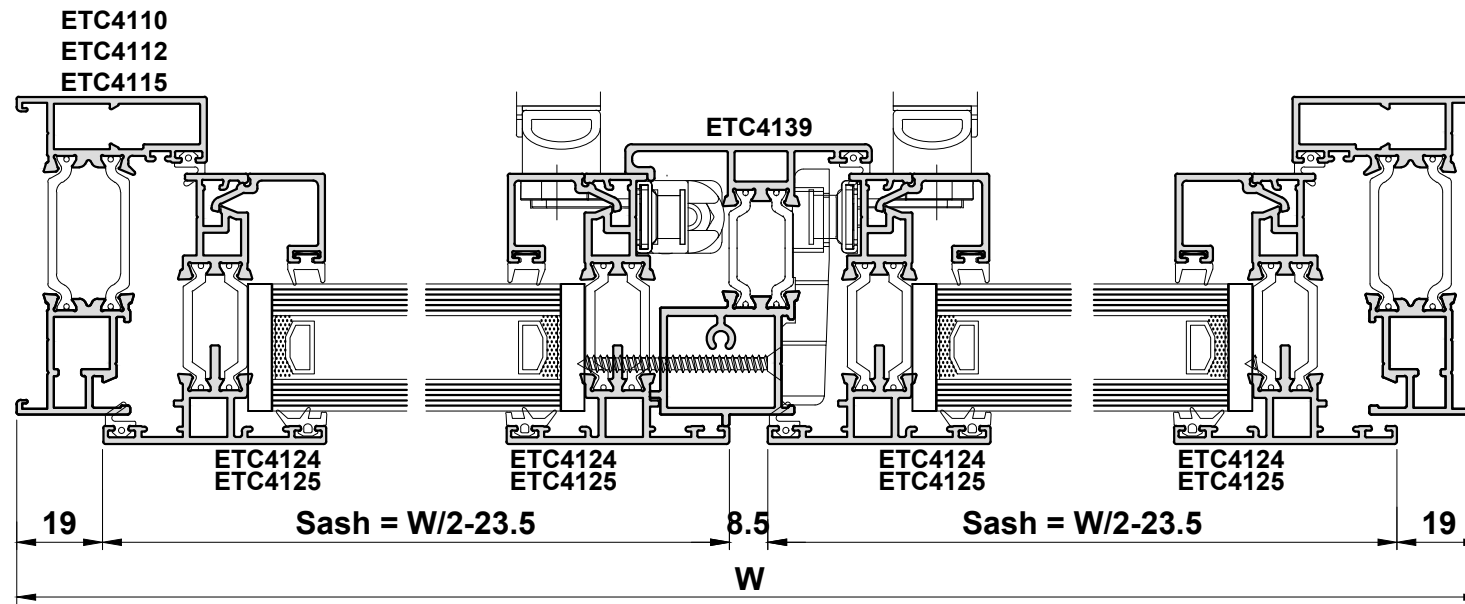
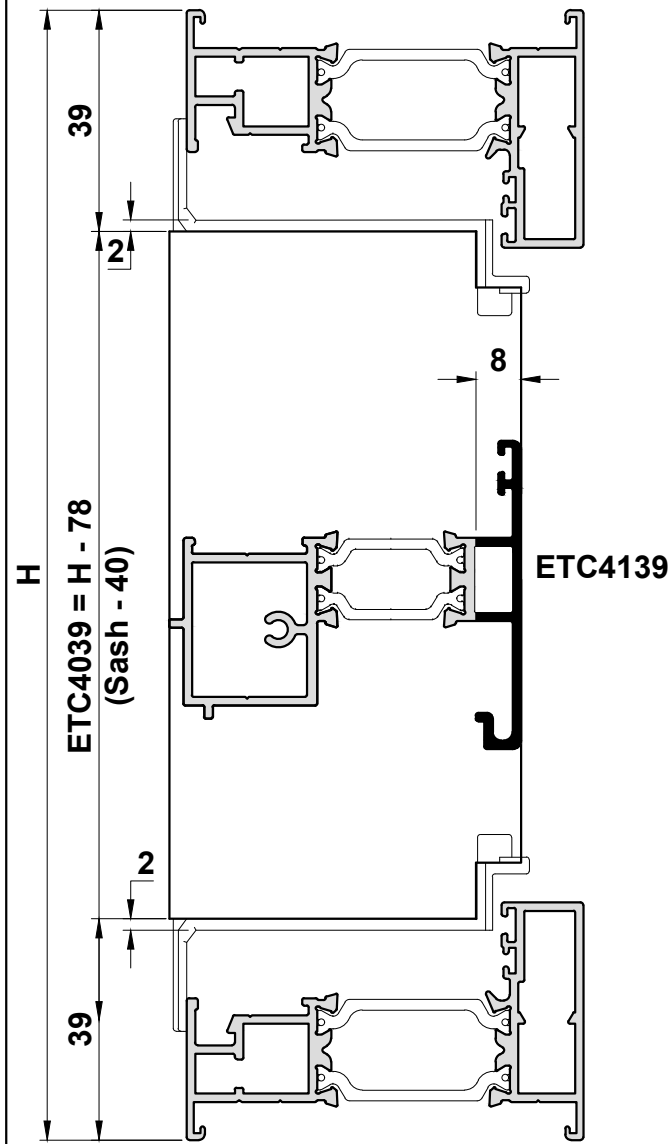


French Casement Assembly



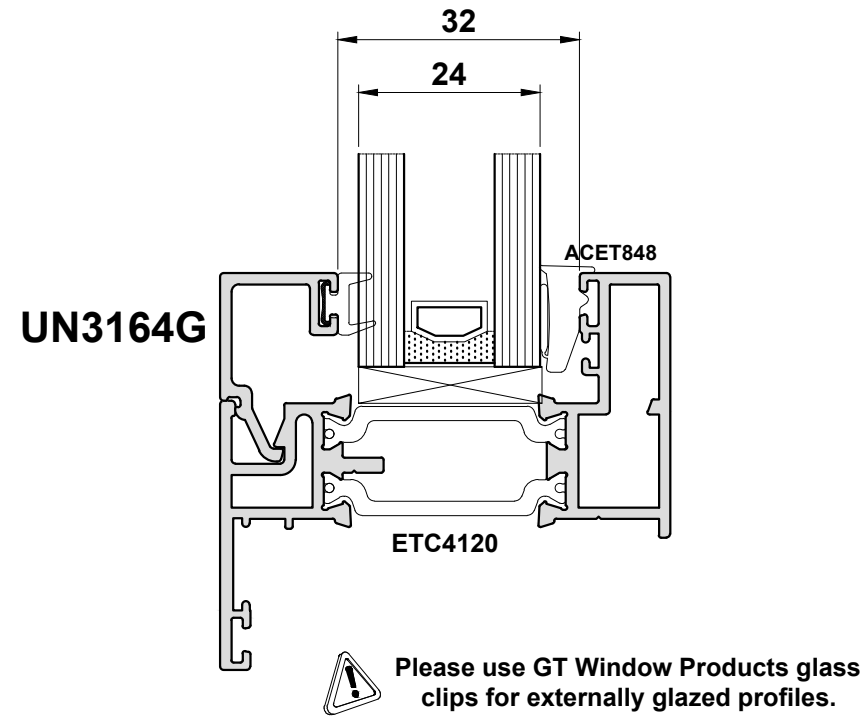
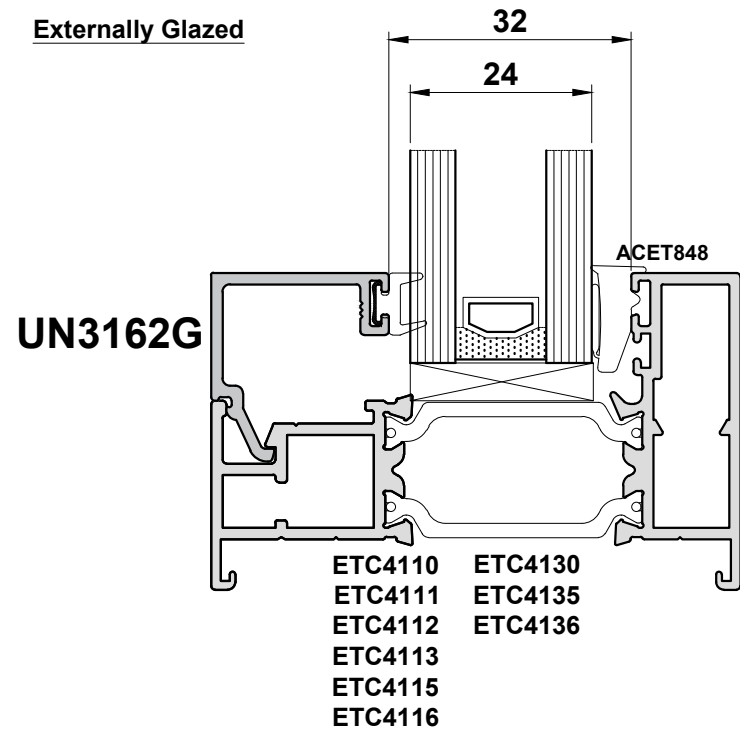
Do Not Scale From This Drawing

French Casement Assembly

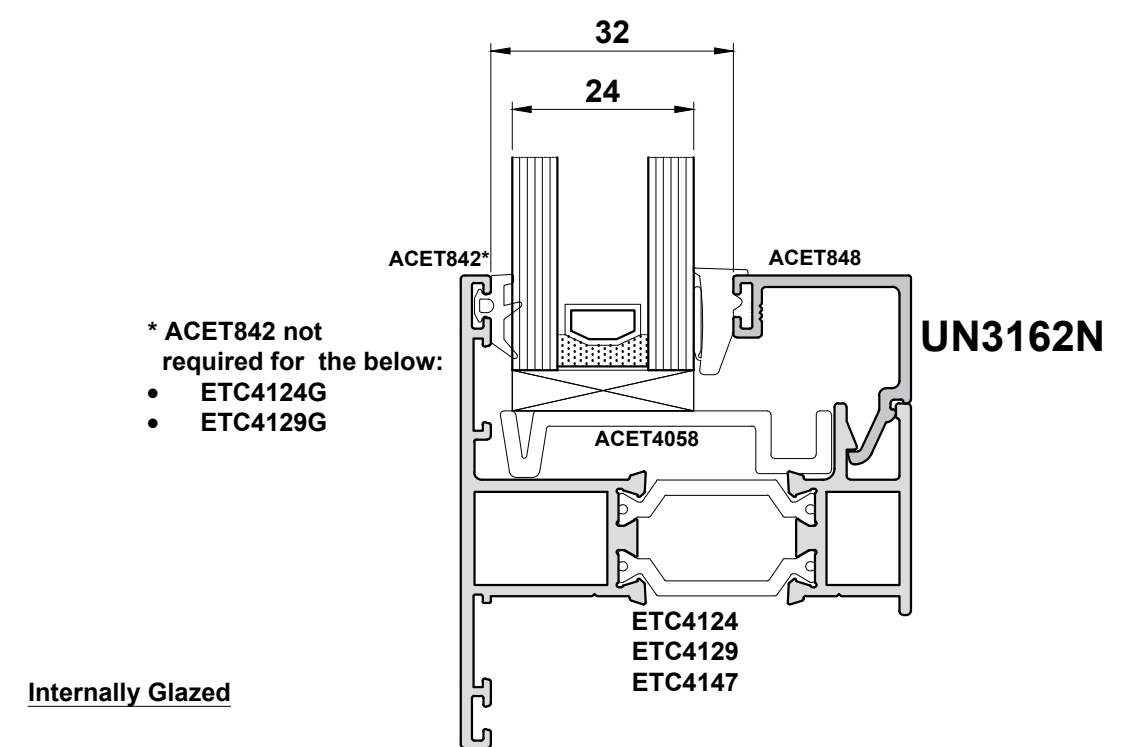
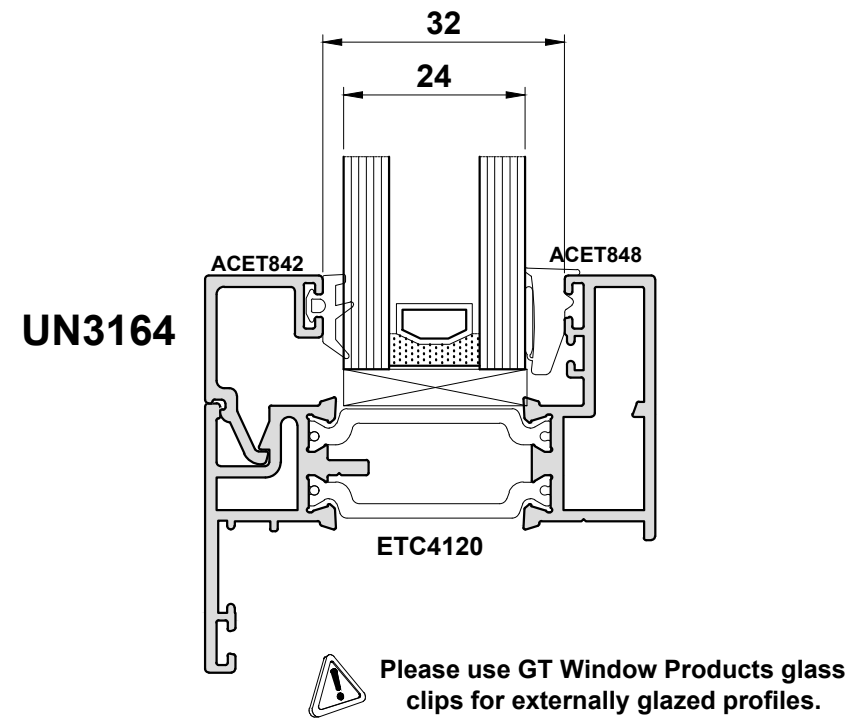
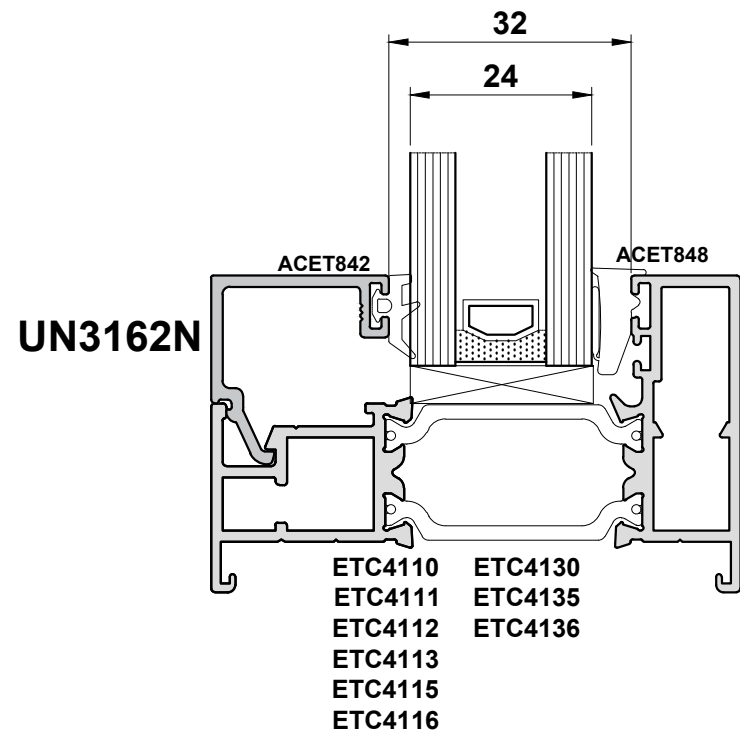
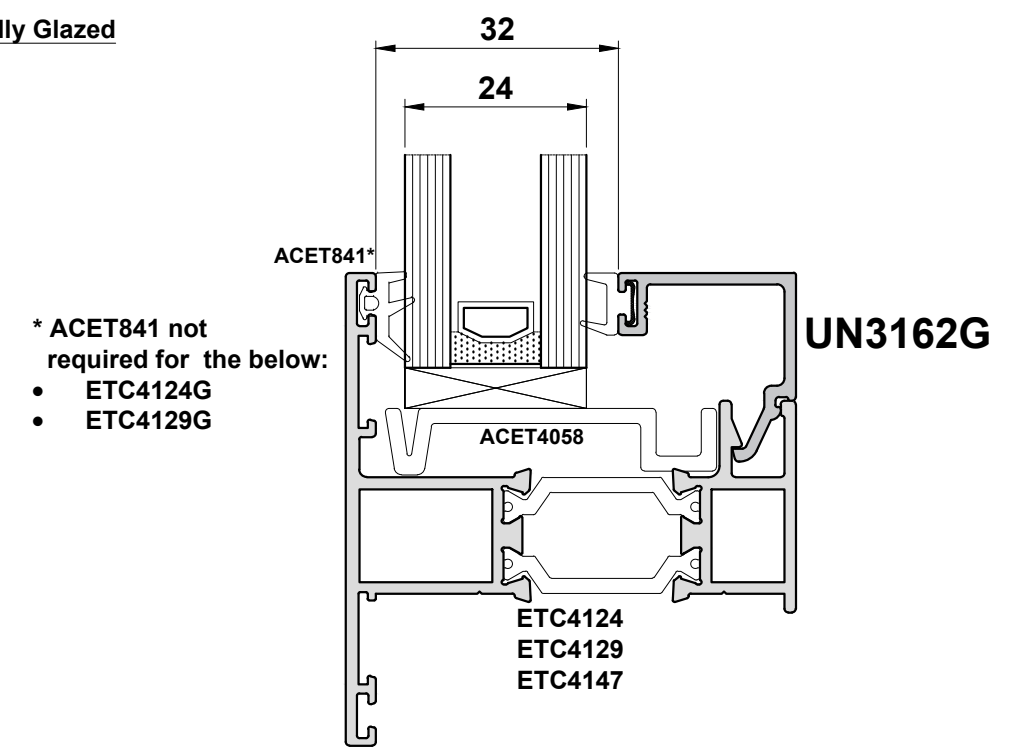


Glazing Chart

Externally Glazed



Internally Glazed



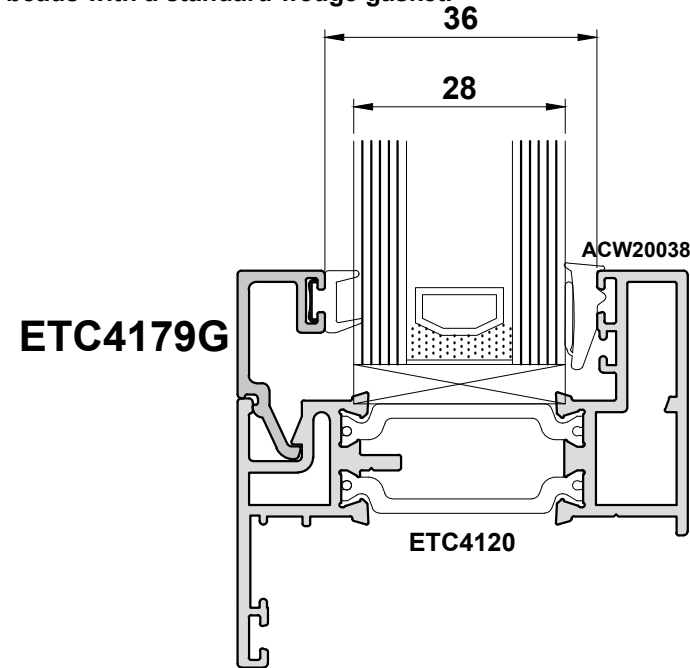
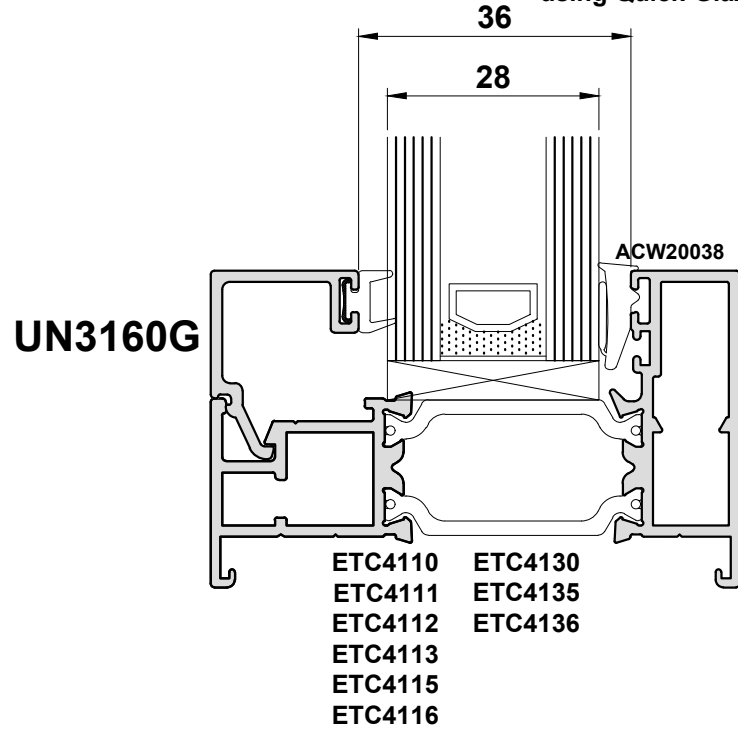
Internally Glazed

Do Not Scale From This Drawing

Glazing Chart

Externally Glazed

Externally glazed Alitherm 400 sections may be glazed using Quick-Glaze beads with a standard wedge gasket.

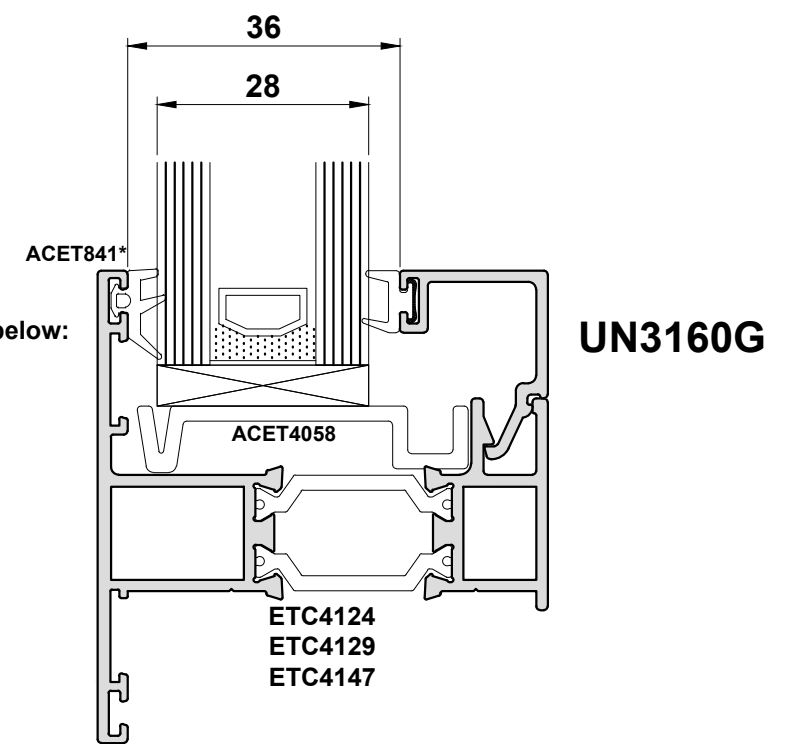


⚠ Please use GT Window Products glass clips for externally glazed profiles.

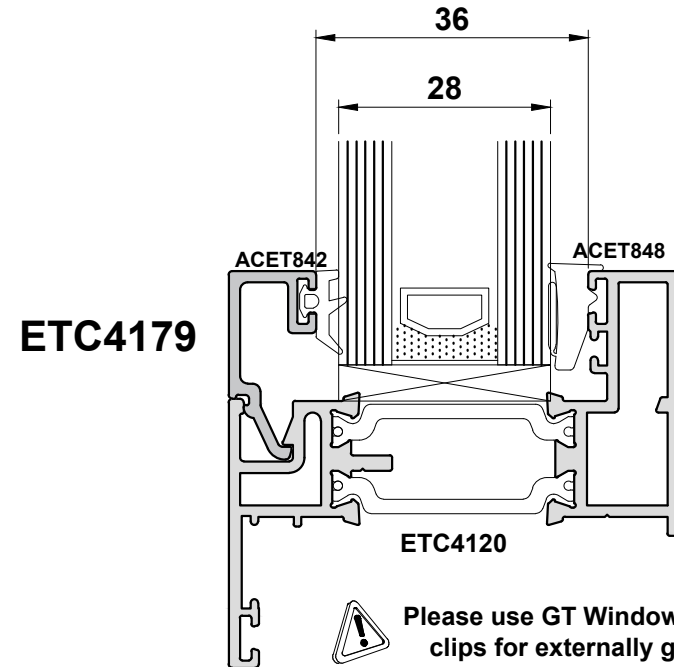
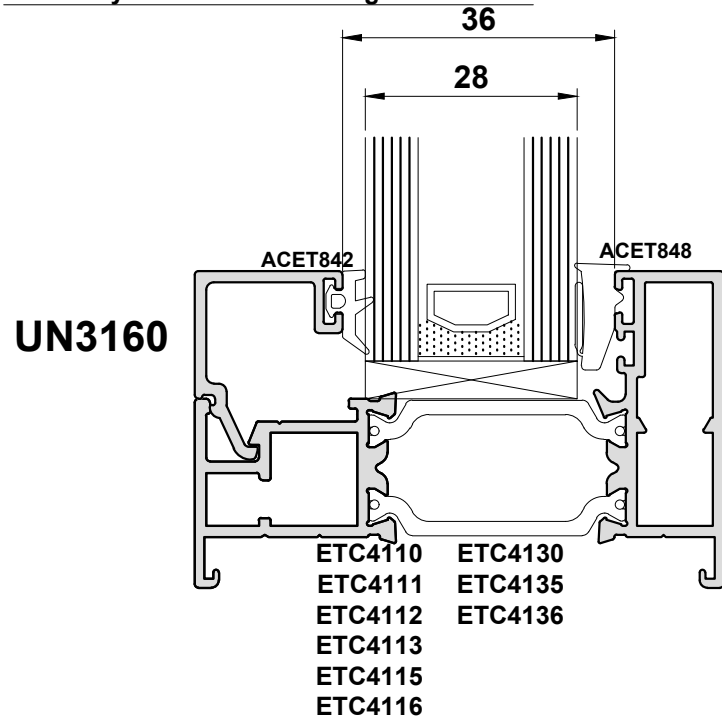
Internally Glazed

* ACET841 not required for the below:

- ETC4124G
- ETC4129G



Externally Glazed without Integrated Gasket

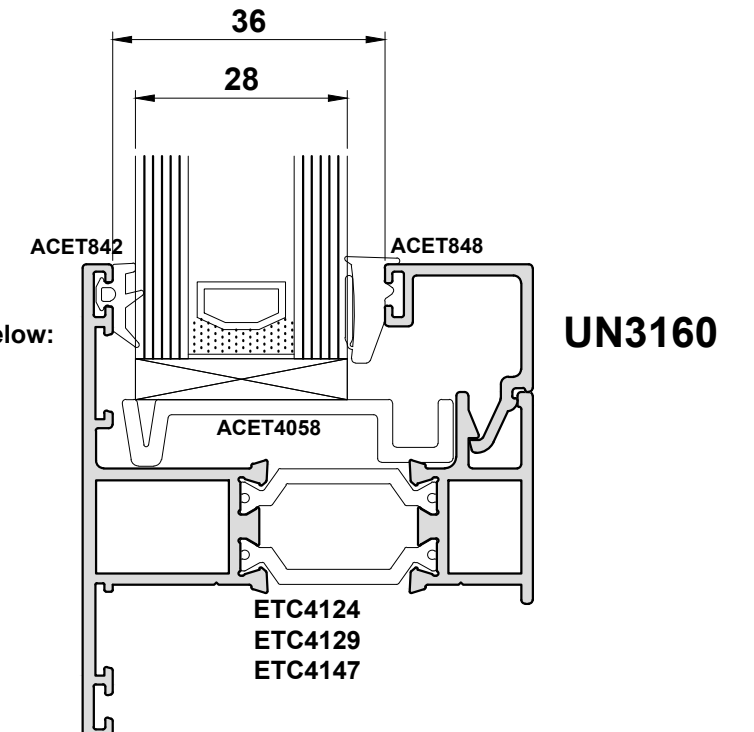


⚠ Please use GT Window Products glass clips for externally glazed profiles.

Internally Glazed

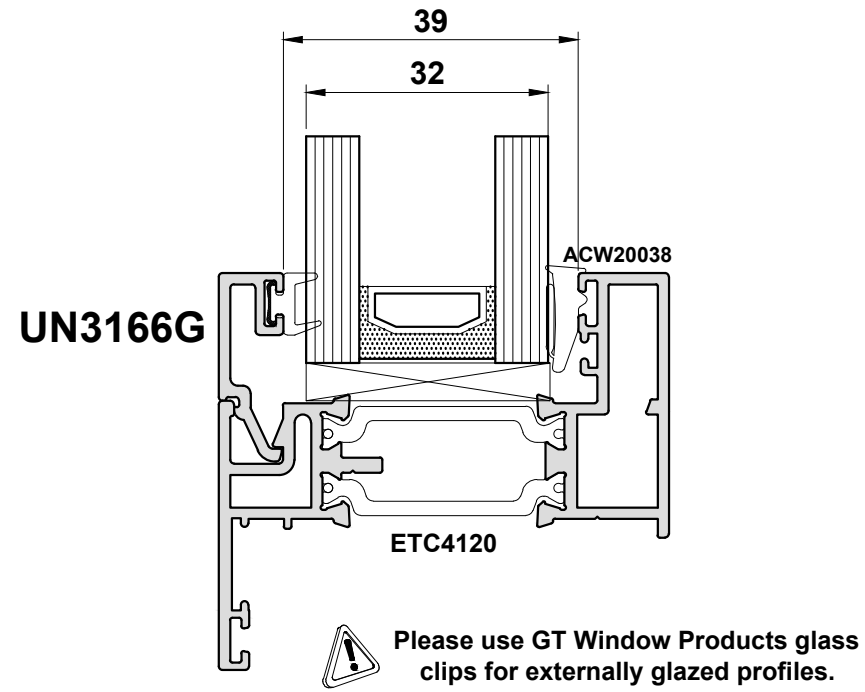
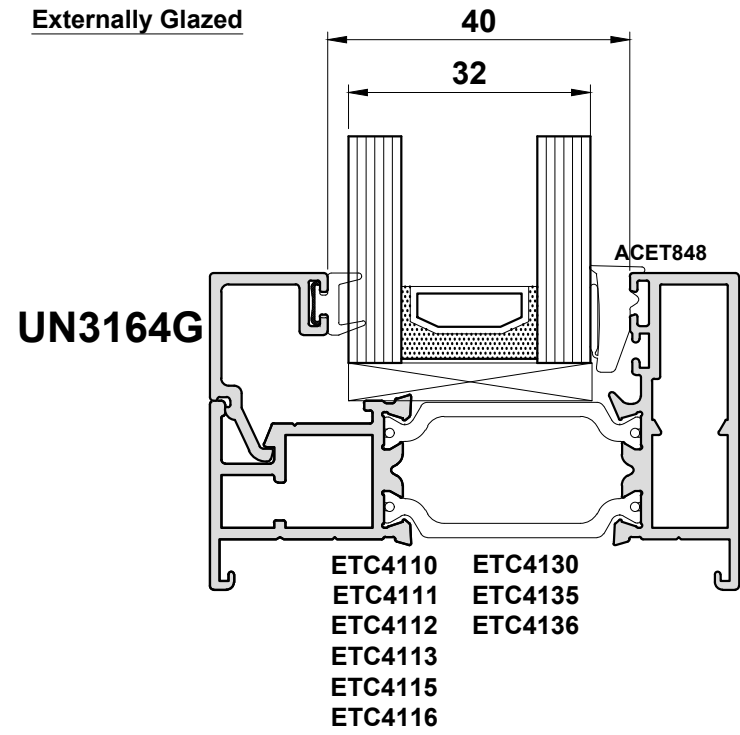
* ACET842 not required for the below:

- ETC4124G
- ETC4129G

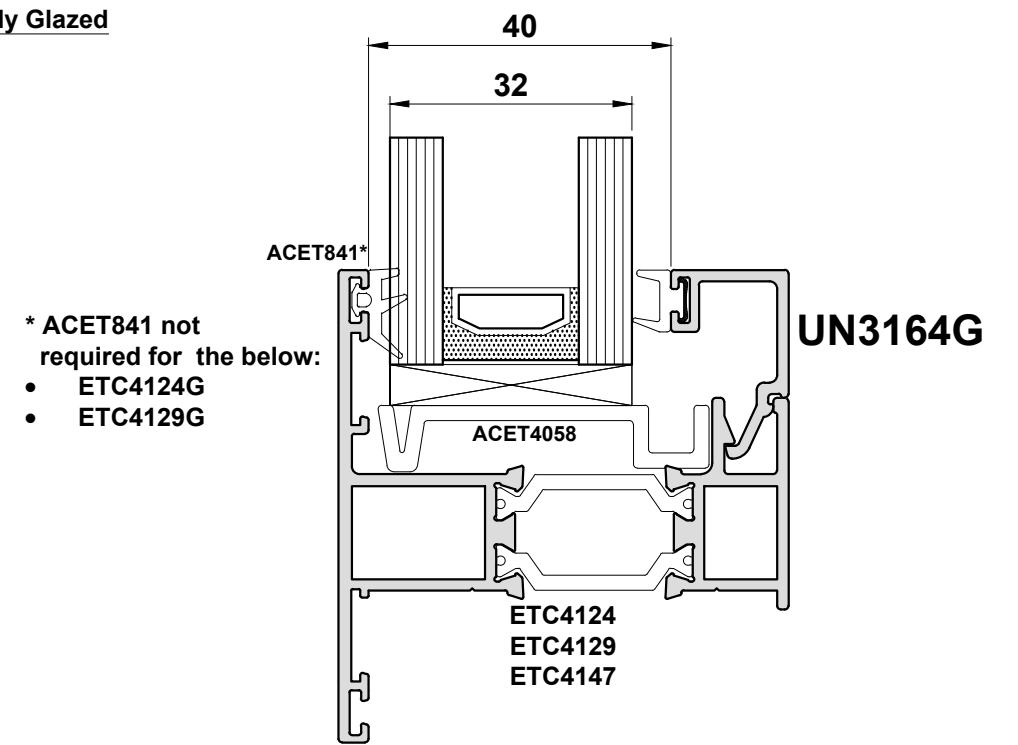


Do Not Scale From This Drawing

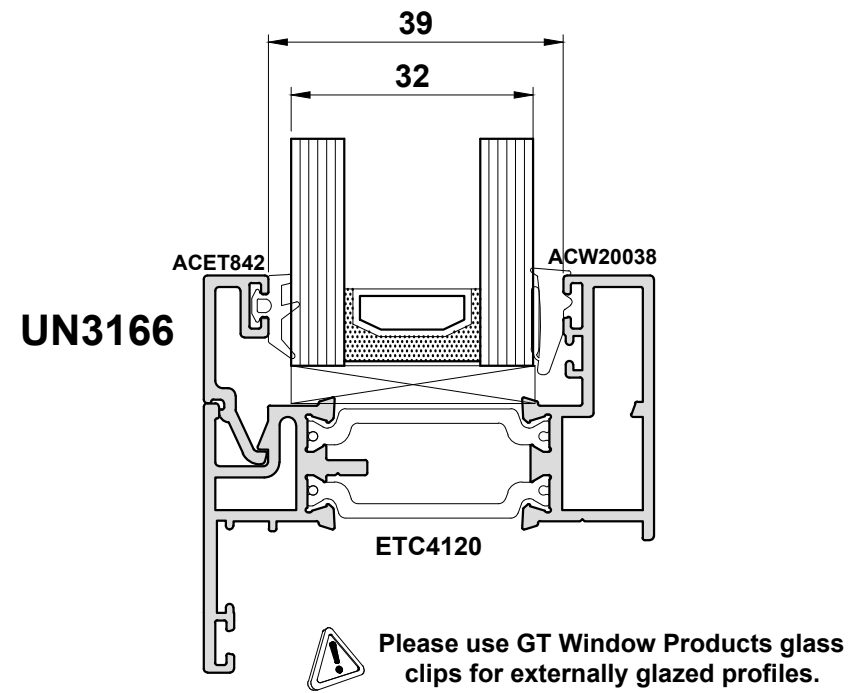
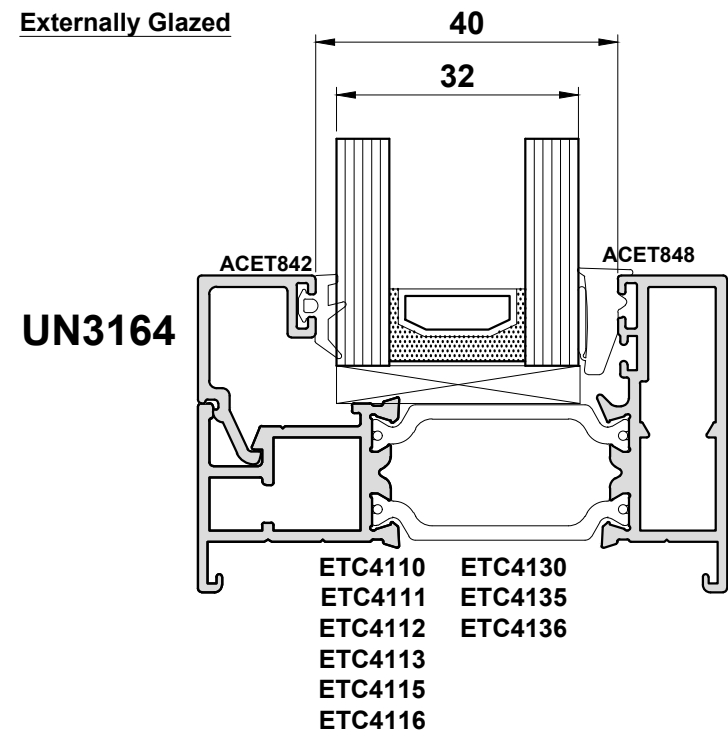
Externally Glazed



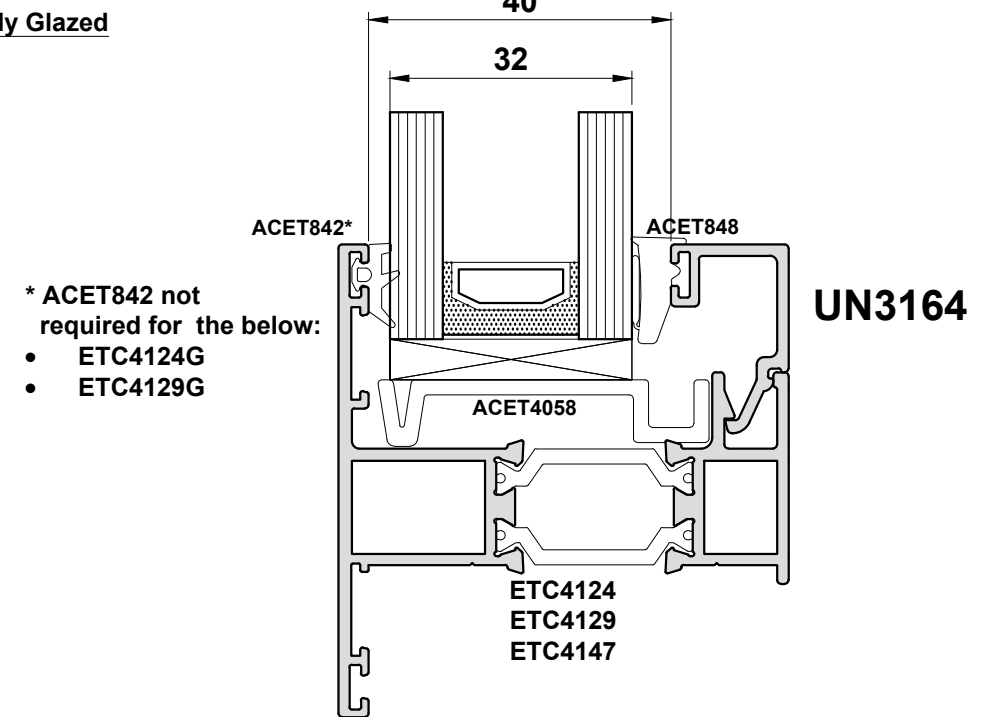
Internally Glazed



Externally Glazed



Internally Glazed

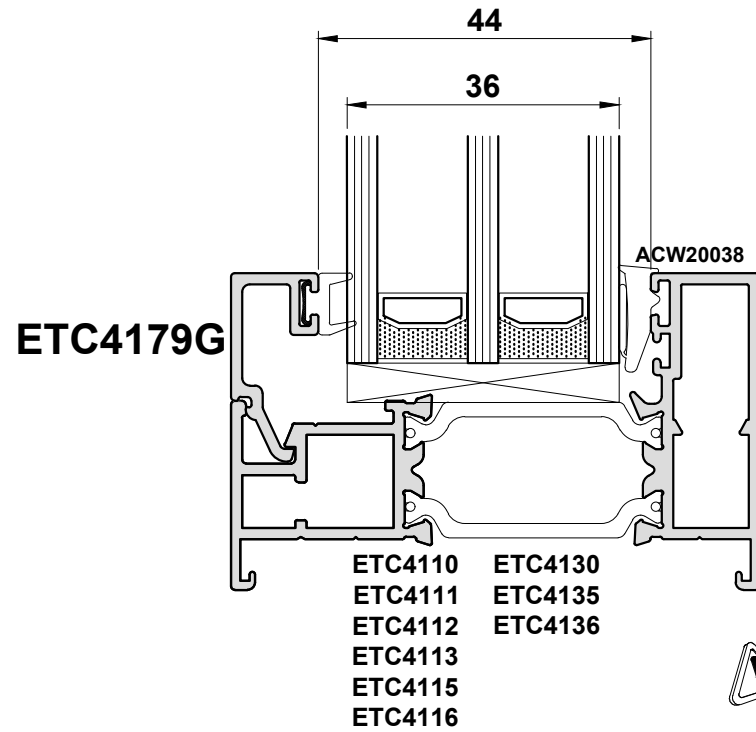


Do Not Scale From This Drawing

Glazing Chart

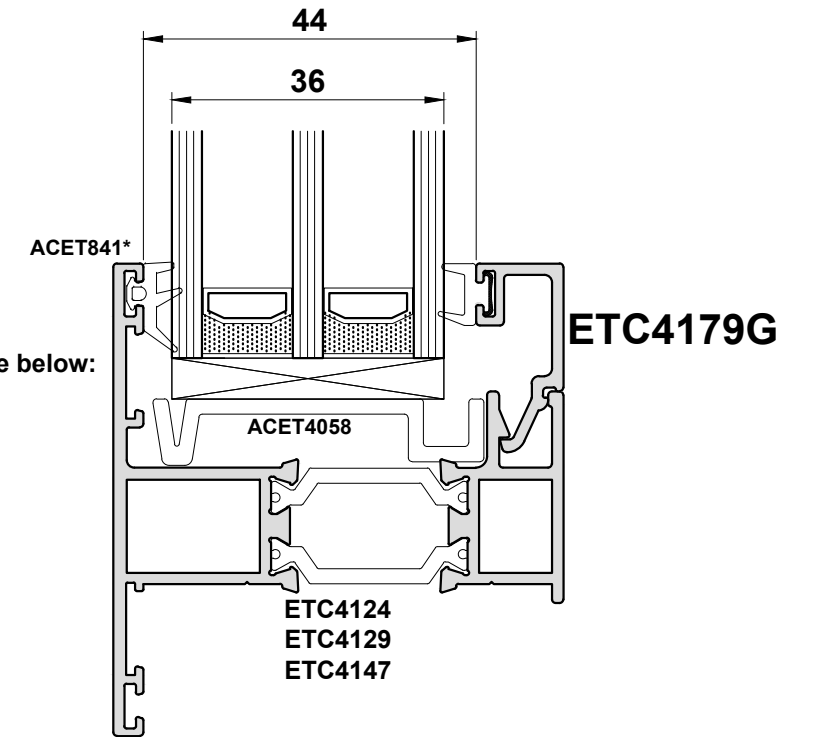
Externally Glazed

Externally glazed Alitherm 400 sections may be glazed using Quick-Glaze beads with a standard wedge gasket.



Please use GT Window Products glass clips for externally glazed profiles.

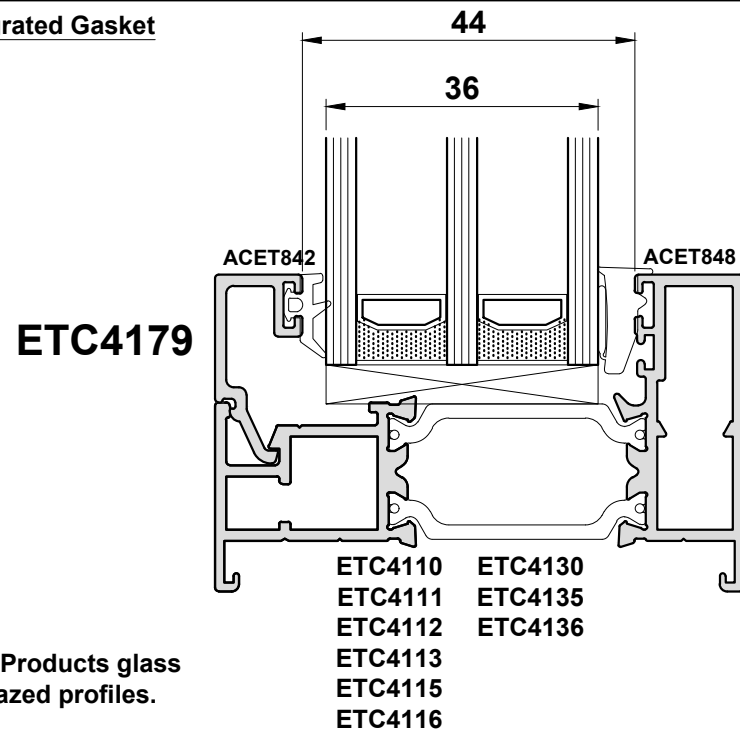
Internally Glazed



* ACET841 not required for the below:

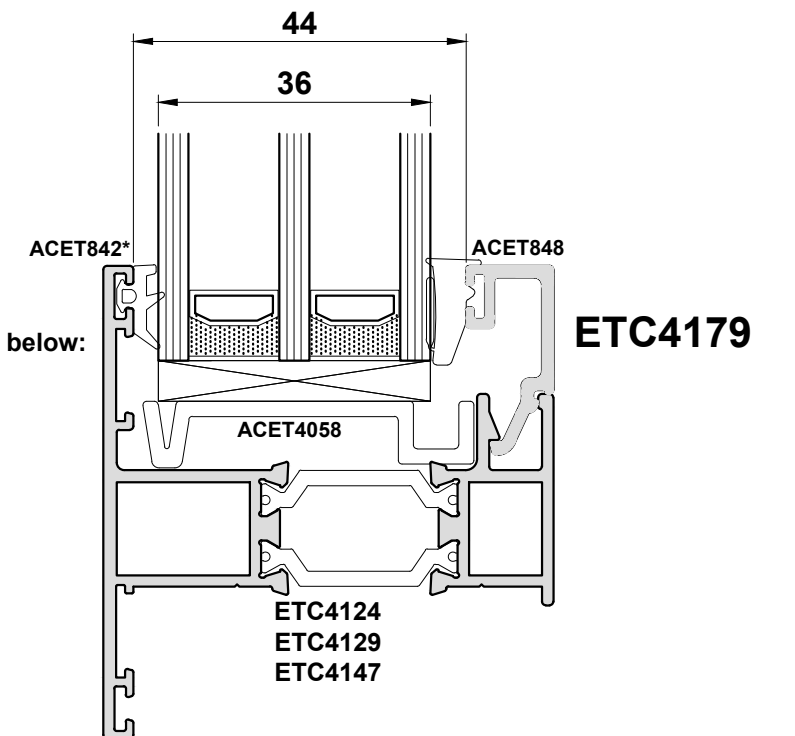
- ETC4124G
- ETC4129G

Externally Glazed without Integrated Gasket



Please use GT Window Products glass clips for externally glazed profiles.

Internally Glazed

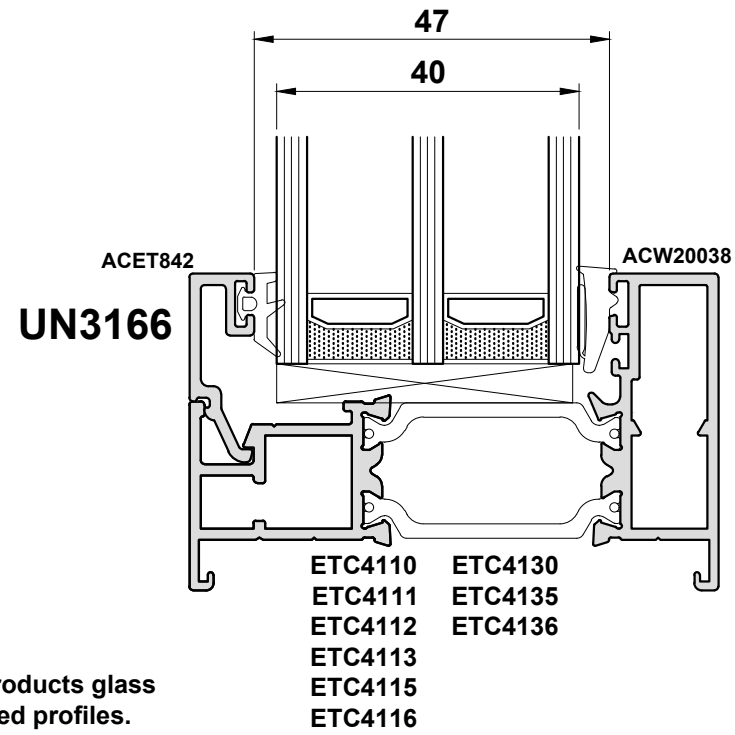


* ACET842 not required for the below:

- ETC4124G
- ETC4129G

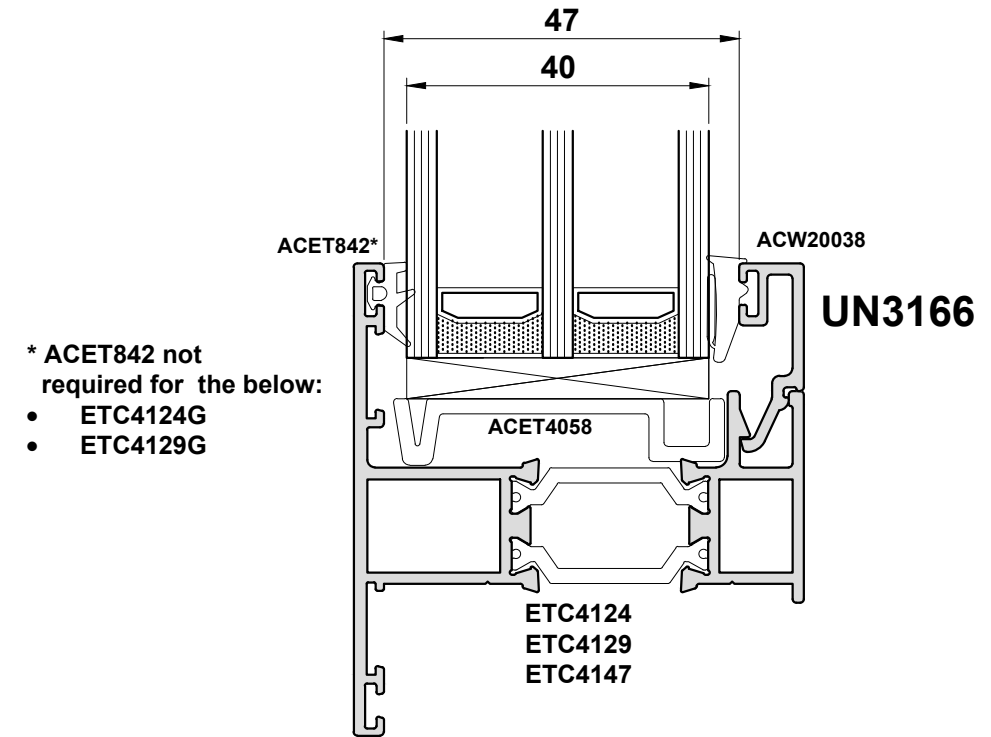
Glazing Chart

Externally Glazed without Integrated Gasket



 Please use GT Window Products glass clips for externally glazed profiles.

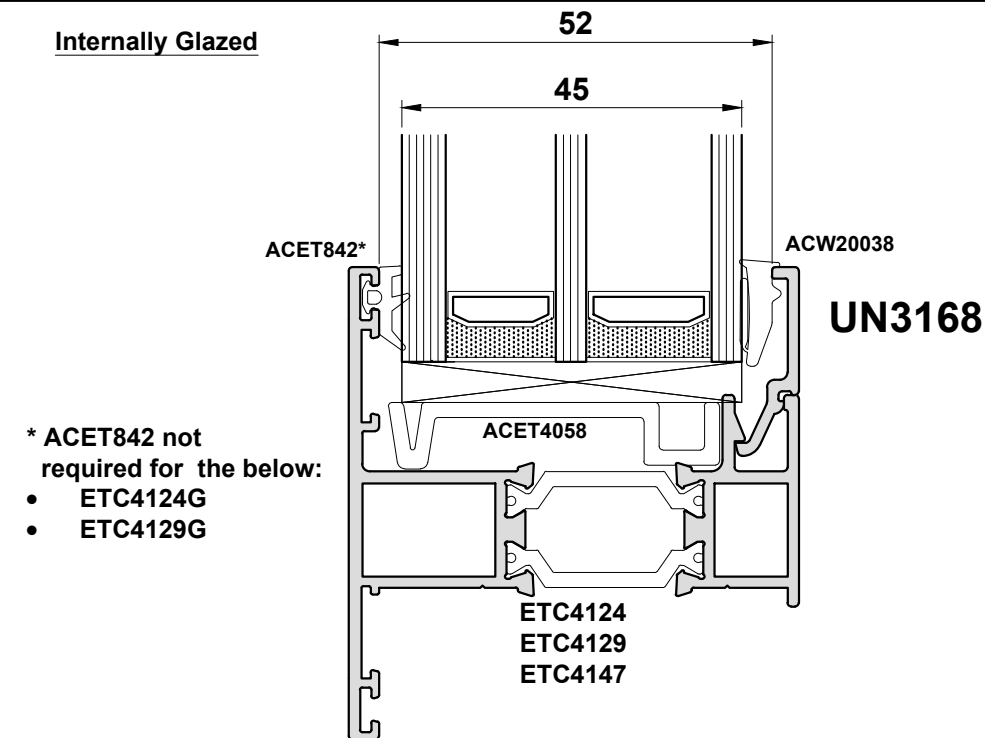
Internally Glazed



* ACET842 not required for the below:

- ETC4124G
- ETC4129G

Internally Glazed

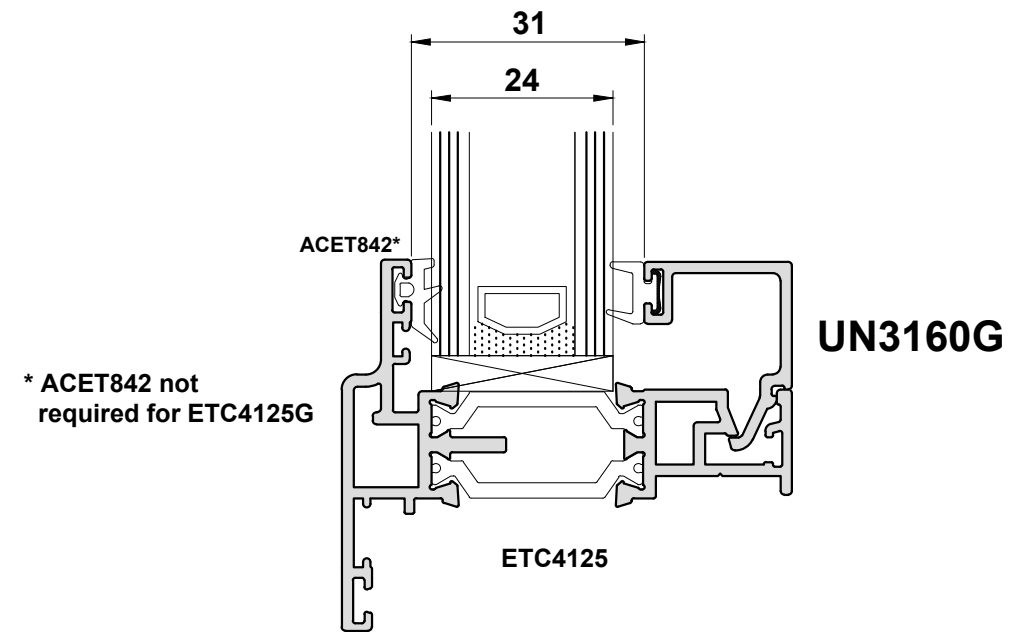
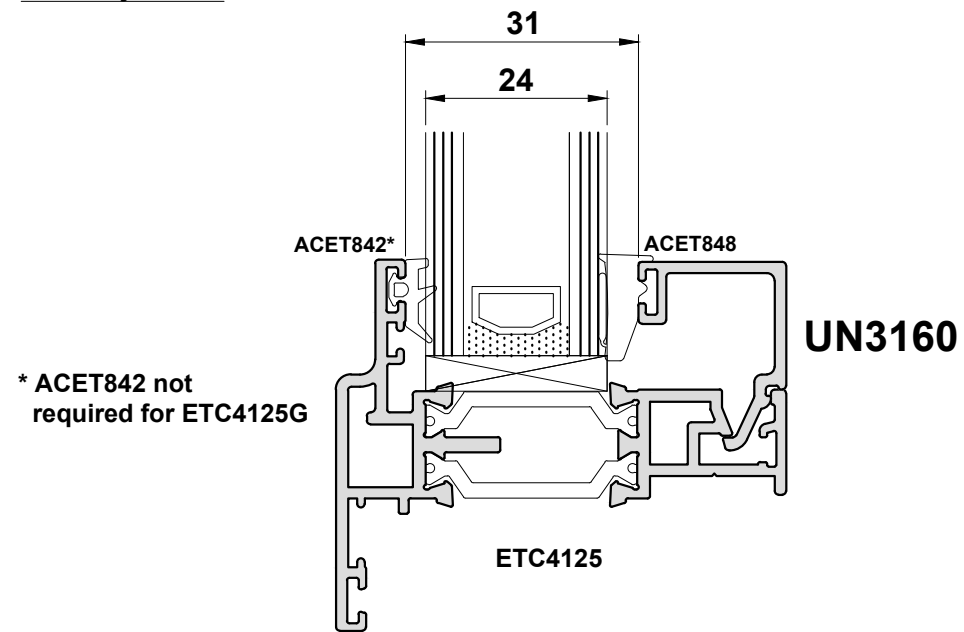


* ACET842 not required for the below:

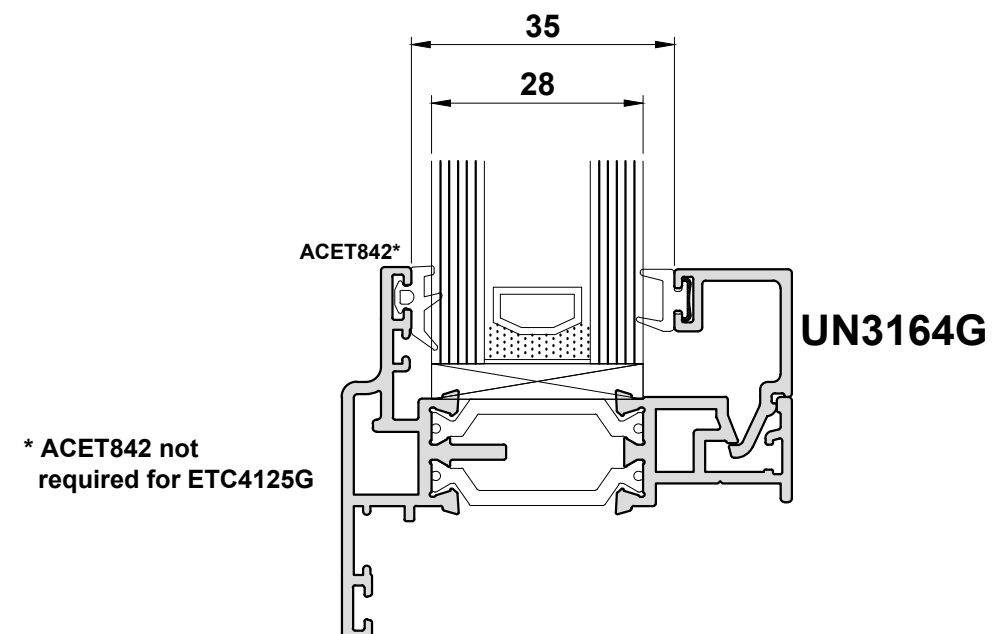
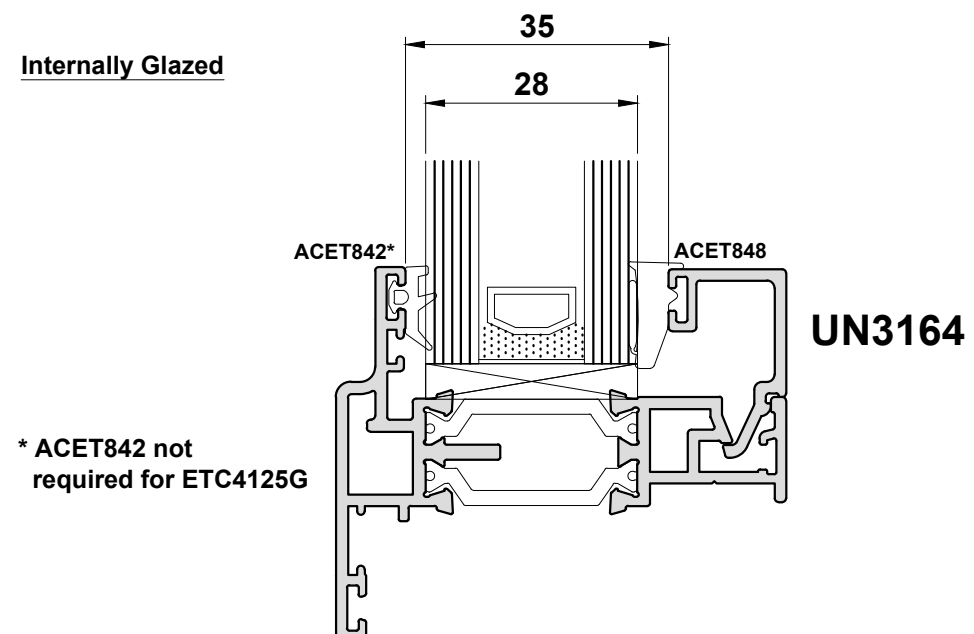
- ETC4124G
- ETC4129G

Do Not Scale From This Drawing

Internally Glazed



Internally Glazed

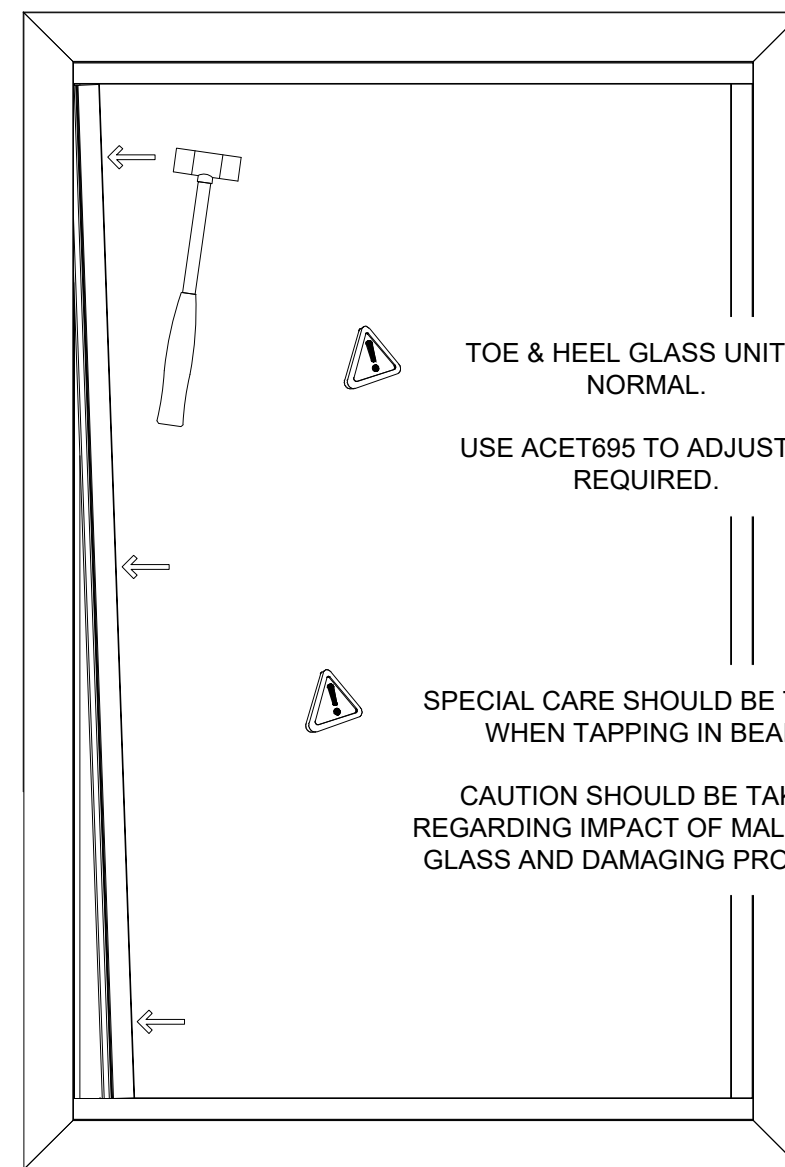
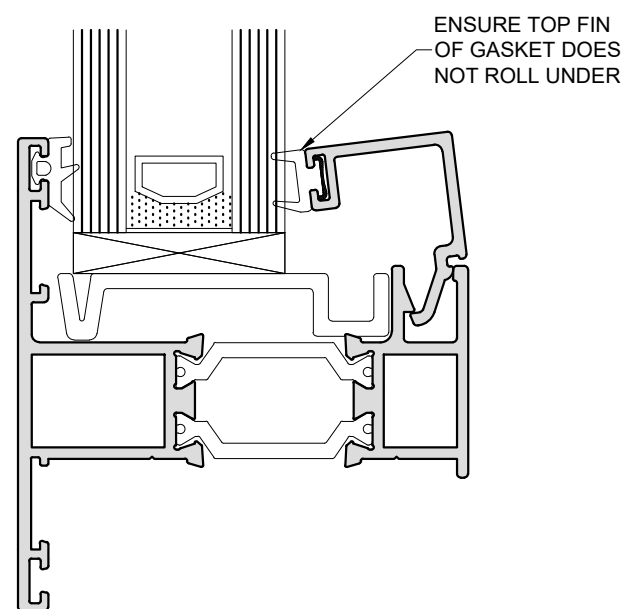
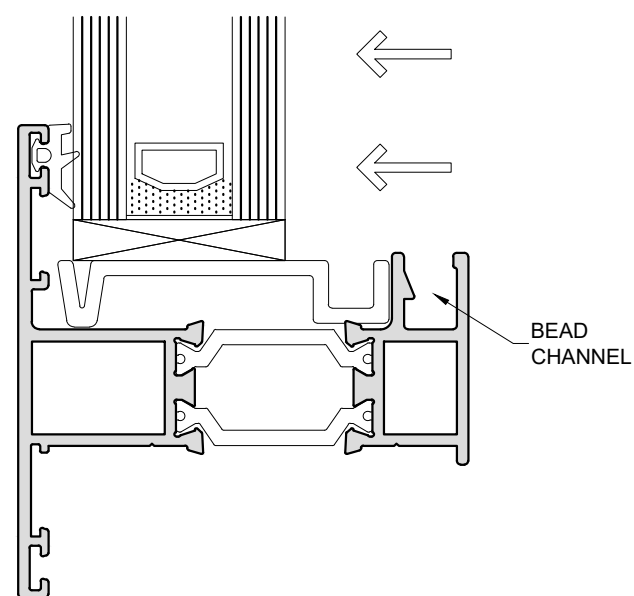
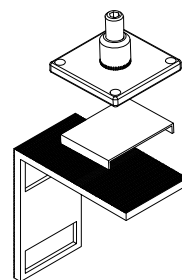


Important Note:
The handle must be fitted through UN3164 bead - see page E22

QUICK-GLAZE BEAD INSTALLATION

1. INSTALL GLASS UNIT, ENSURING IT HAS BEEN PUSHED FORWARD TO ENGAGE COMPRESSION OF E GASKET.
2. BEGINNING WITH HORIZONTAL BEADS, LOCATE BEAD IN CLIP CHANNEL OF SASH AS SHOWN. INTEGRATED GASKET MAY REST AGAINST GLASS UNIT.
3. APPLY FIRM PRESSURE TO THE BEAD TO HOLD IN POSITION. THIS MAY CAUSE THE BEAD TO FULLY LOCK INTO POSITION.
4. USING A NYLON MALLET, TAP BEAD INTO CHANNEL WORKING FROM ONE END TO THE OTHER. PLEASE TAKE CARE AT THIS STAGE TO AVOID DAMAGE TO BOTH THE GLAZING UNIT AND THE BEAD.
5. REPEAT STEPS 2 - 4 TO INSTALL VERTICAL BEADS.

WE STRONGLY RECOMMEND INSTALLING ACET695 GLASS ADJUSTERS WHEN USING QUICK-GLAZE BEADS. THIS WILL REMOVE THE NEED TO REMOVE BEADS IN ORDER TO ADJUST GLASS POSITION.



Quick-Glaze Bead Removal

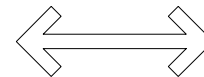
KEEP INTEGRATED GASKET

QUICK-GLAZE BEAD REMOVAL

1. STARTING ON VERTICAL BEADS, APPLY PRESSURE TO BEAD IN DIRECTION SHOWN IN ORDER TO CREATE SMALL GAP BETWEEN SASH AND BEAD.
2. GENTLY INSERT DE-GLAZING TOOL TAKING PARTICULAR CARE AS NOT TO DAMAGE PAINT FINISH.
3. SLOWLY PRISE THE BEAD UP AND AWAY FROM THE SASH.
4. THE BEAD SHOULD NOW BE EASILY REMOVABLE FROM QUICK-GLAZE BEAD CHANNEL IN SASH

BEAD AND INTEGRATED GASKET CAN BE REUSED.

OR

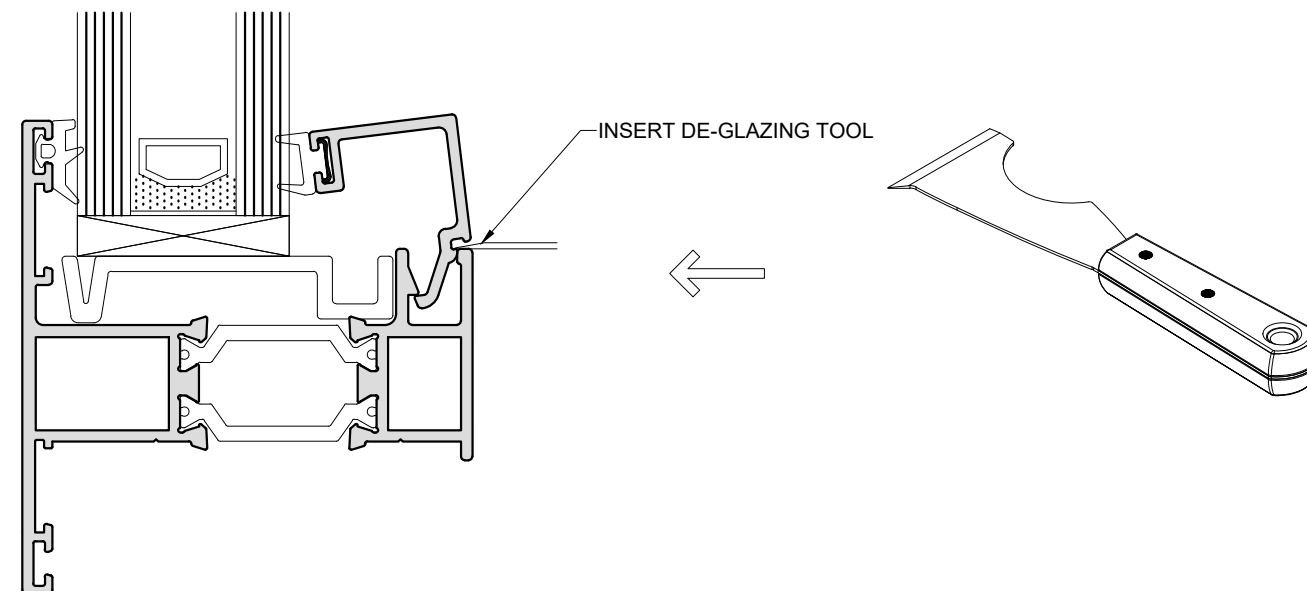
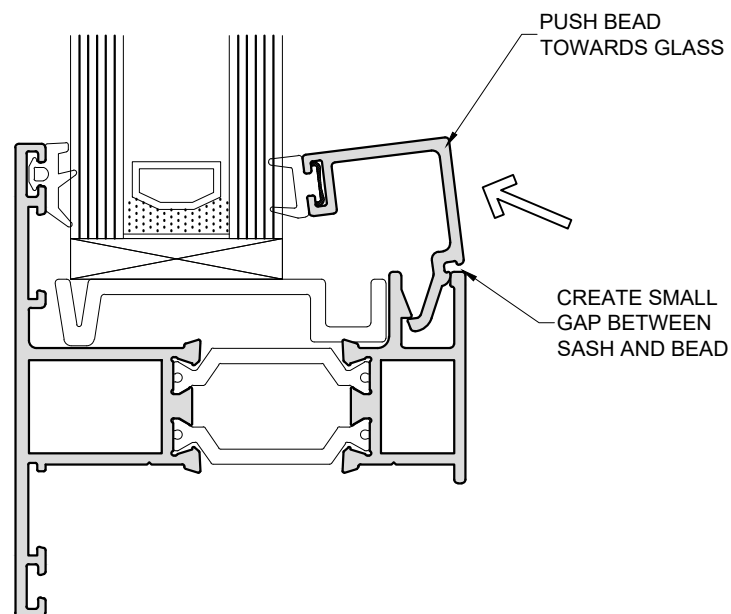


REPLACE INTEGRATED GASKET

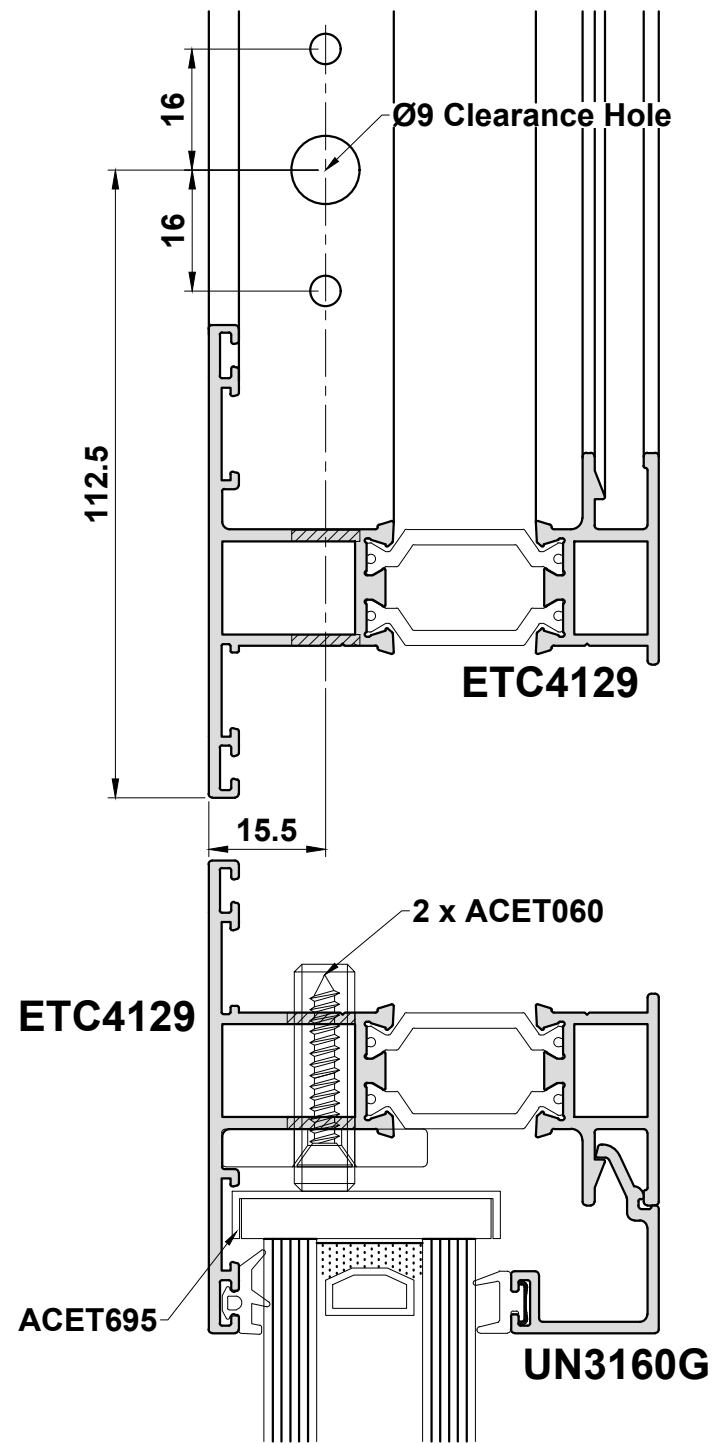
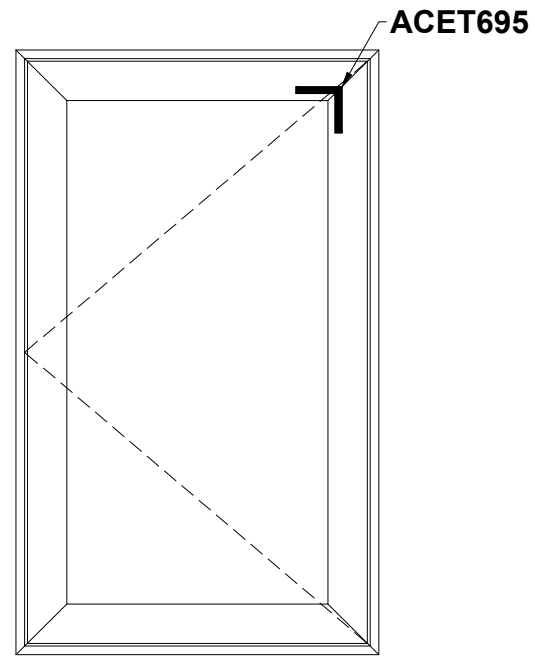
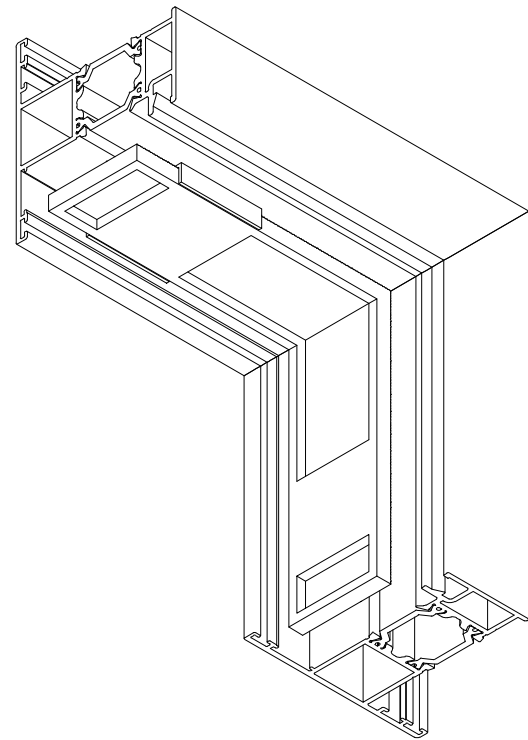
QUICK-GLAZE BEAD REMOVAL

1. USING SMALL FLAT HEADED SCREWDRIVER OR SIMILAR, WEDGE TIP BETWEEN CO EXTRUDED GASKET AND ALUMINIUM.
2. IN A LEVERING MOTION, PRISE THE GASKET AWAY FROM THE ALUMINIUM. PARTICULAR CARE SHOULD BE TAKEN NOT TO DAMAGE THE GLASS UNIT AND ALUMINIUM.
3. COMPLETE THIS AT SEVERAL LOCATIONS ALONG THE LENGTH OF THE BEAD.
4. REMOVE GASKET AND DISCARD. THIS GASKET CAN NO LONGER BE USED.
5. THE BEAD SHOULD NOW BE EASILY REMOVABLE FROM TAP IN BEAD CHANNEL IN SASH

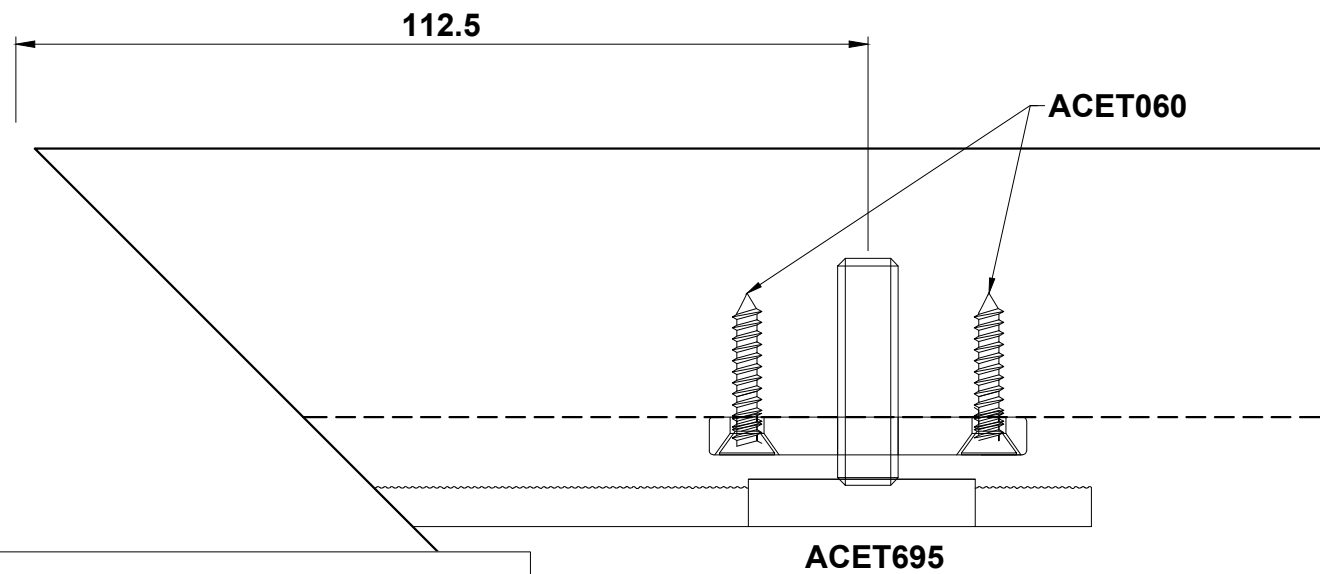
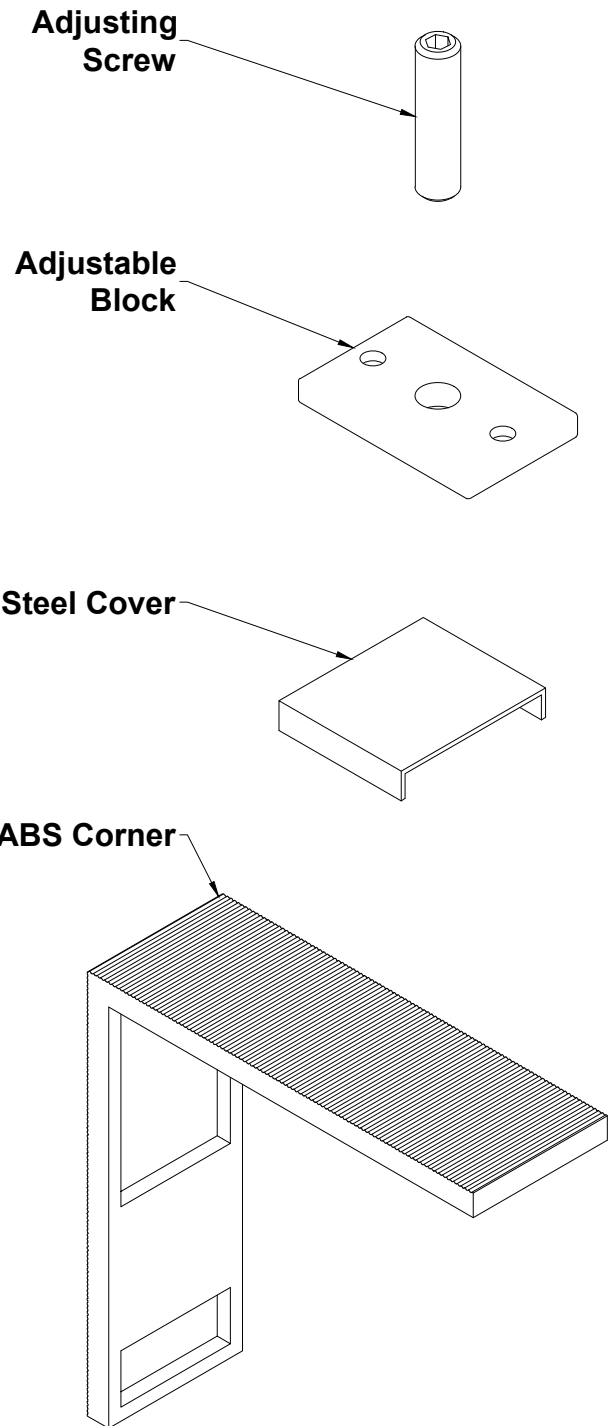
PLEASE SEE GLAZING CHART FOR REPLACEMENT GASKET CODES.



Quick-Glaze Bead Glass Adjuster



ACET695 Kit Includes:

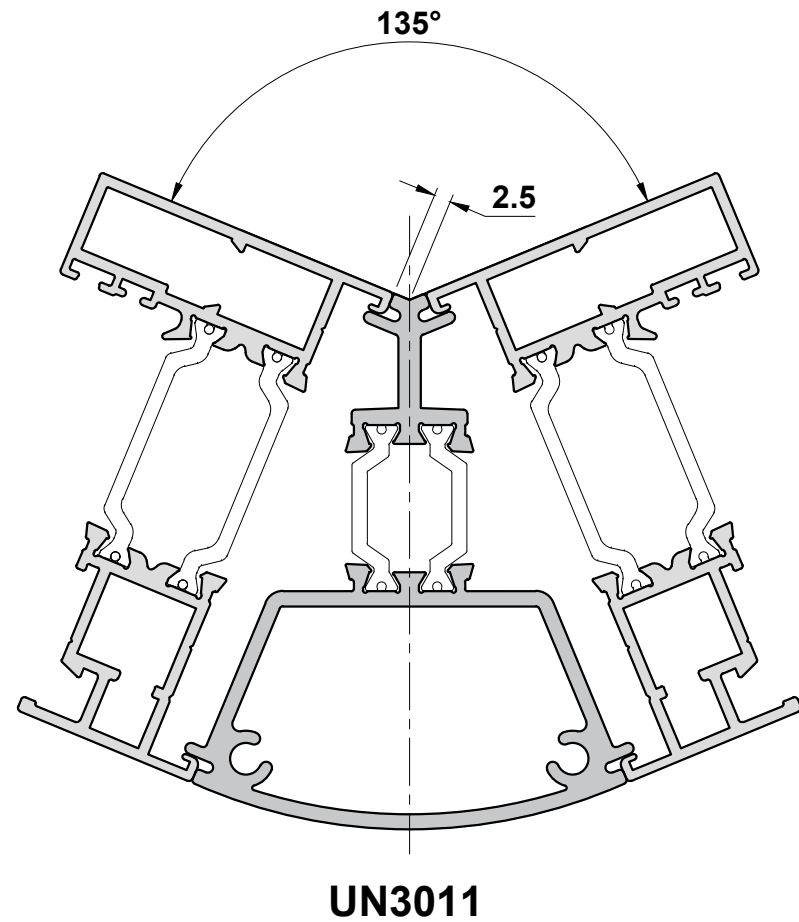


WE STRONGLY RECOMMEND INSTALLING ACET695 GLASS ADJUSTERS WHEN USING QUICK-GLAZE BEADS. THIS WILL REMOVE THE NEED TO REMOVE BEADS IN ORDER TO ADJUST GLASS POSITION.

Fixed Bay Pole Angle / Deduction

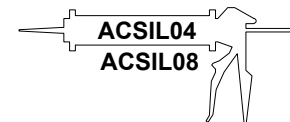
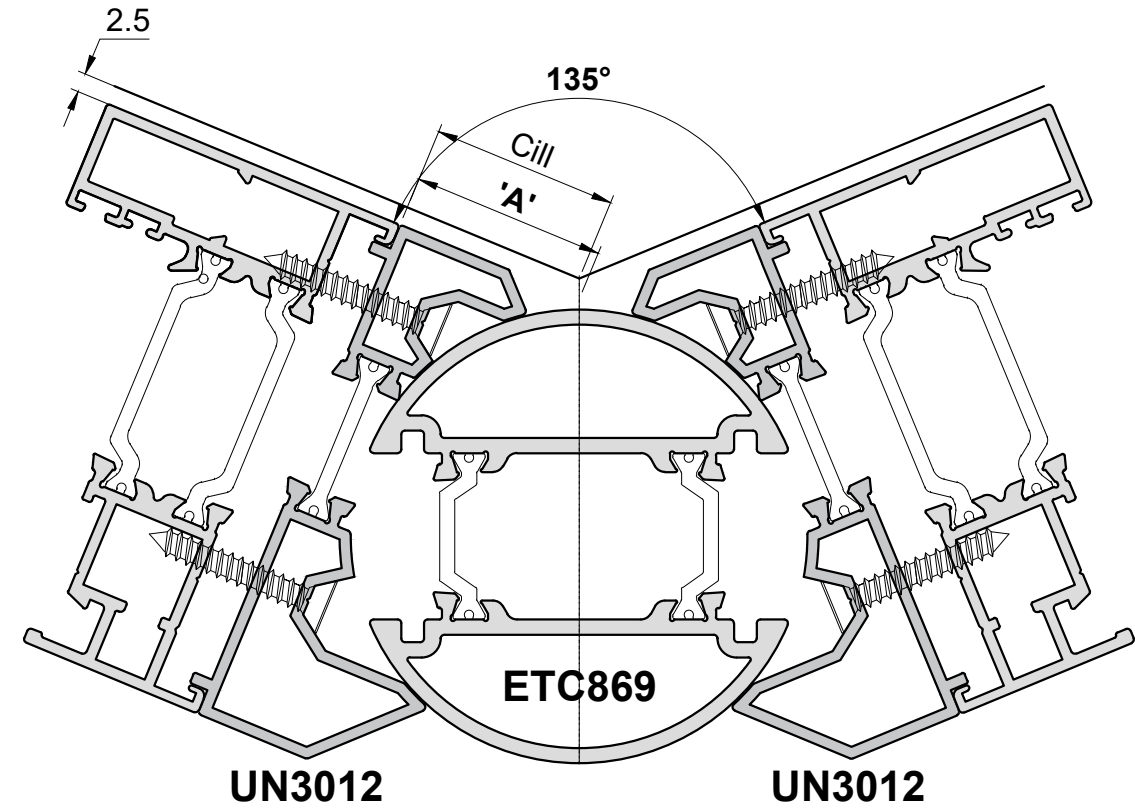
Sections

ETC4110
ETC4111
ETC4112
ETC4115



Sections

ETC4110
ETC4111
ETC4112
ETC4115

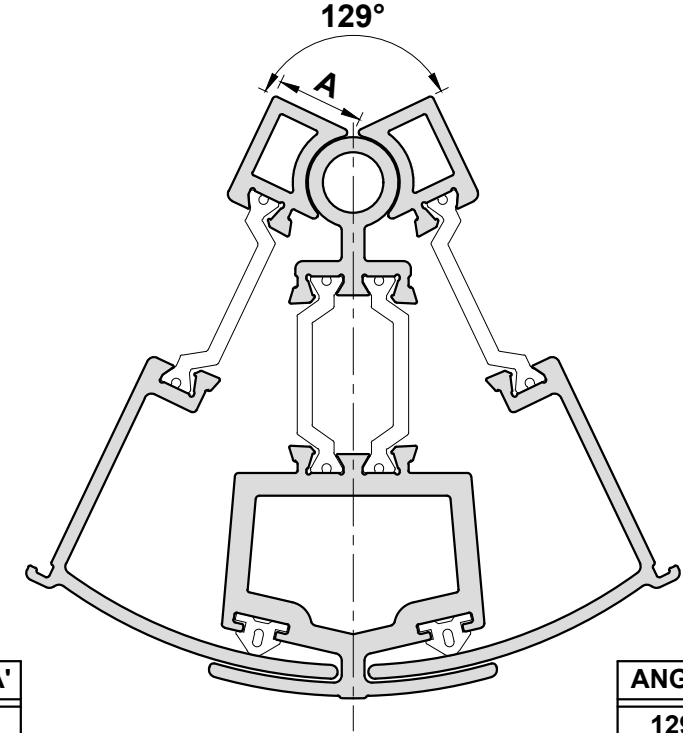
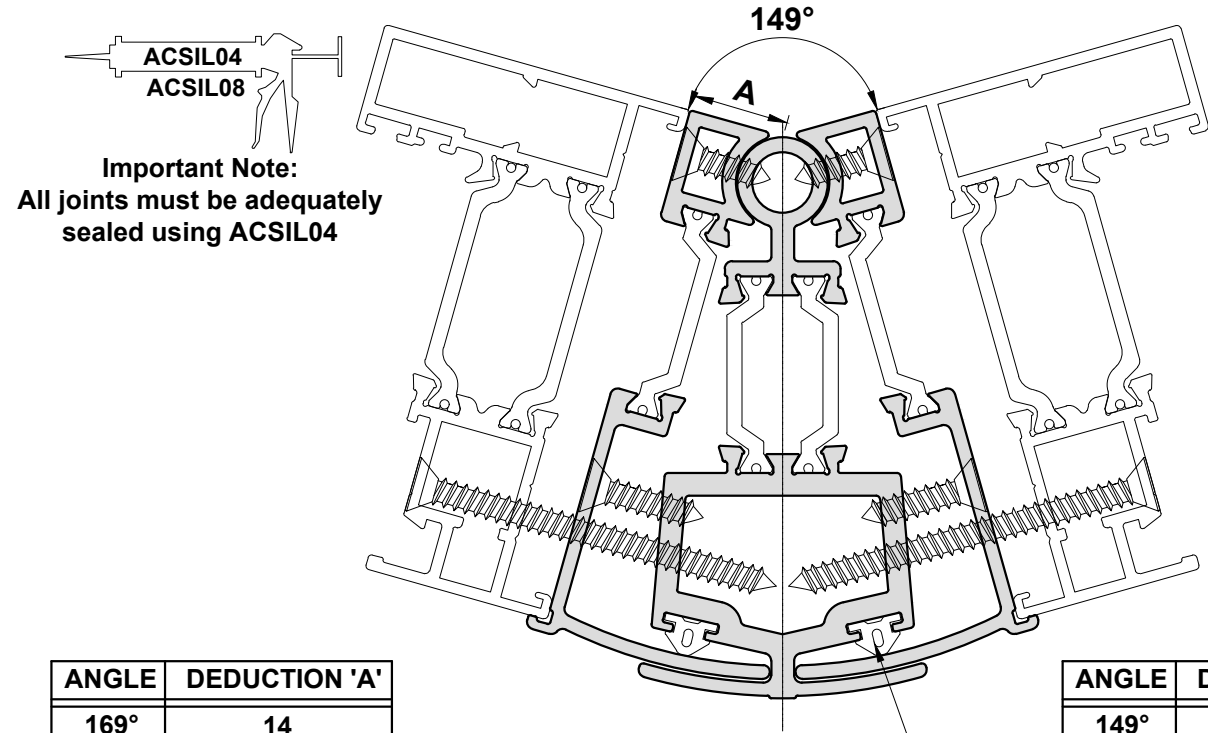
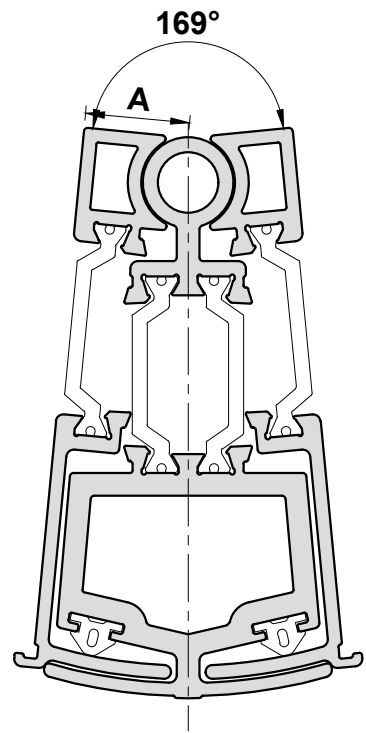


Important Note:
All joints must be adequately sealed using ACSIL04

ANGLE	DEDUCTION 'A'	INT. CILL DEDUCTION
180°	37.5	37.5
175°	36	36
170°	35	35
165°	33.5	33.5
160°	32.5	32
155°	31	30.5
150°	30	29
145°	28.5	27.5
140°	27	26
135°	25.5	24.5

'A' & Cill deductions are the same at angles 180°-165°

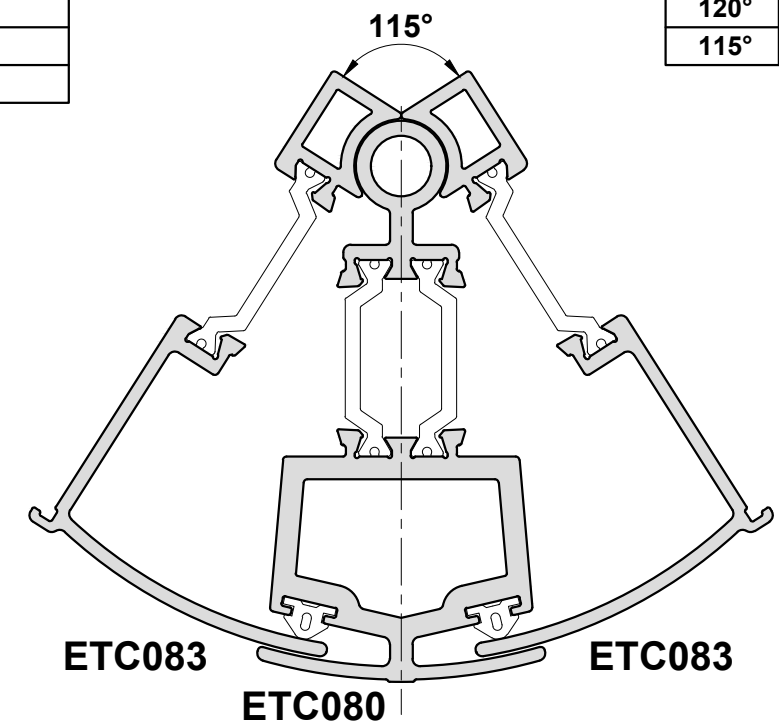
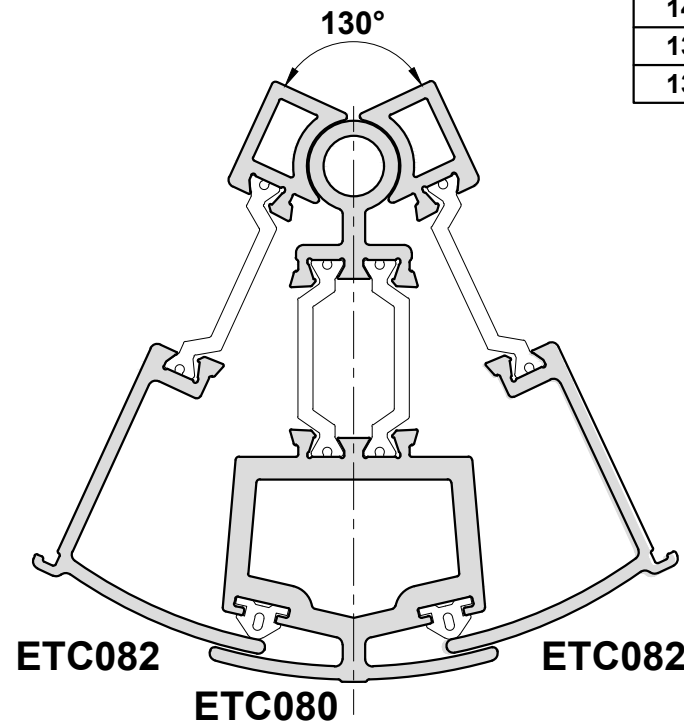
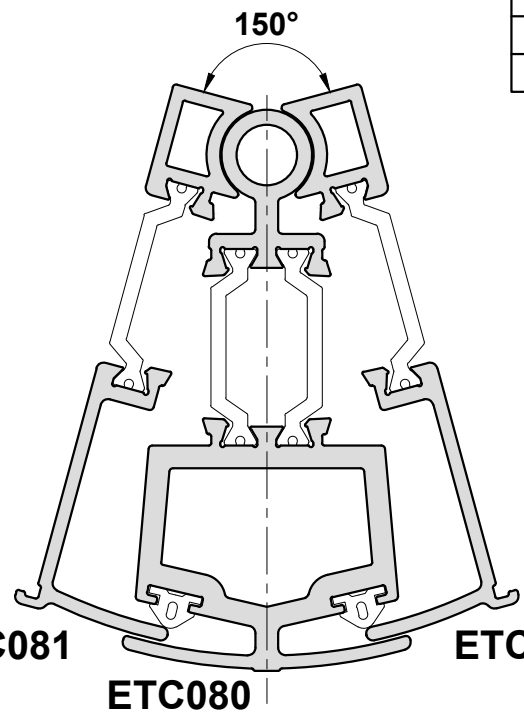
70mm Outer Frame Bay Pole Angles/Deductions

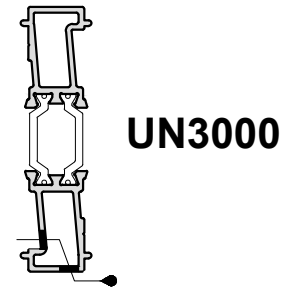
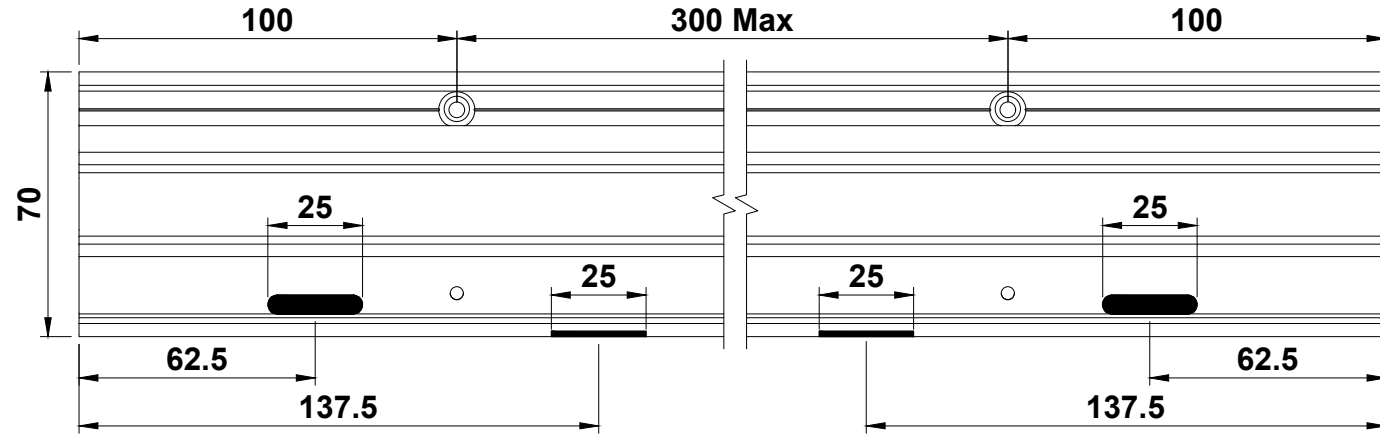


ANGLE	DEDUCTION 'A'
169°	14
165°	13.5
160°	13.6
155°	13
150°	13

ANGLE	DEDUCTION 'A'
149°	12.5
145°	12.5
140°	12
135°	12
130°	11.5

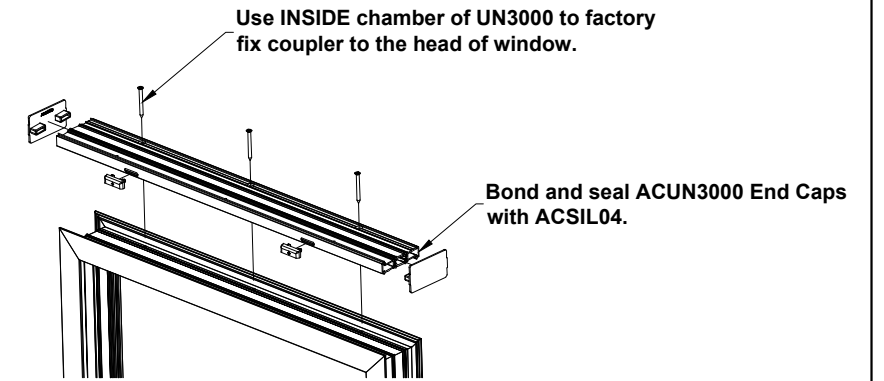
ANGLE	DEDUCTION 'A'
129°	11.5
125°	11.5
120°	11
115°	10.5



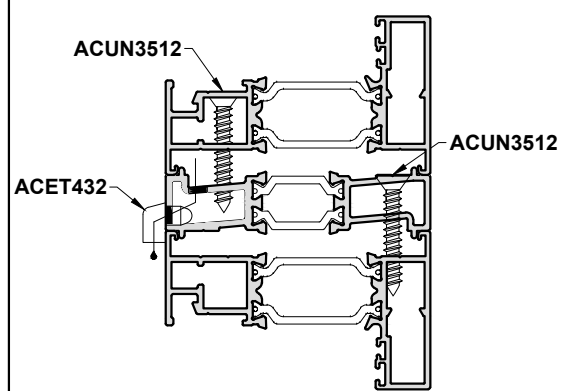


Zone Drainage of Jamb Cavity

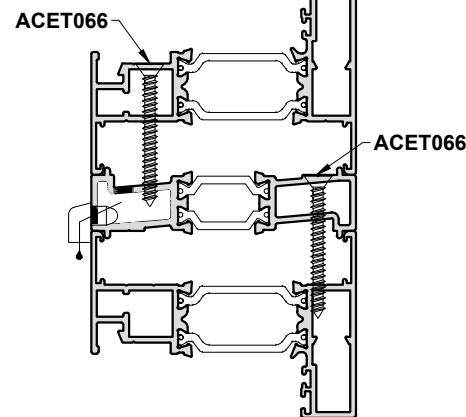
CWCT Built up wall guidance recommends drainage of Jamb Cavity



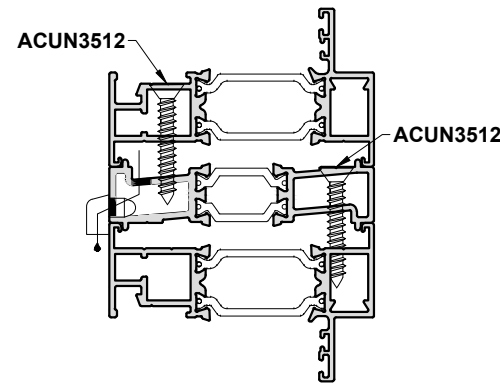
Important Note: Seal all joints to UN3000 using ACSIL04.



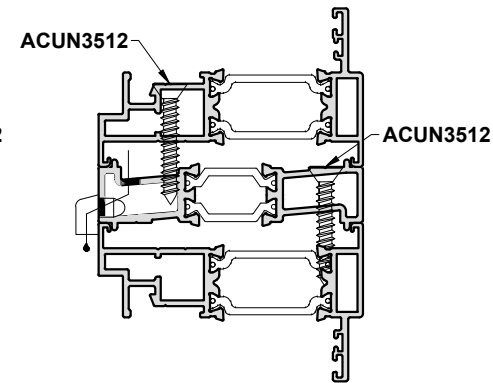
ETC4110



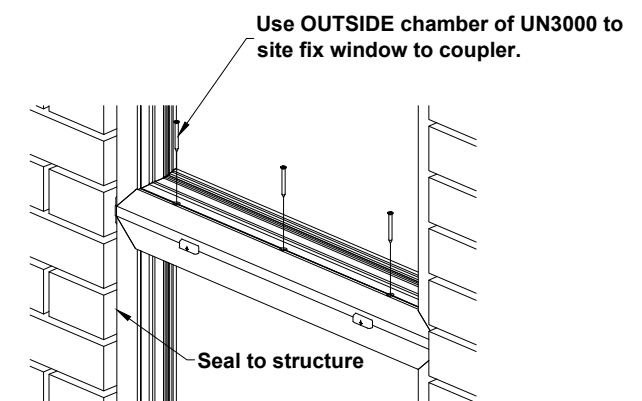
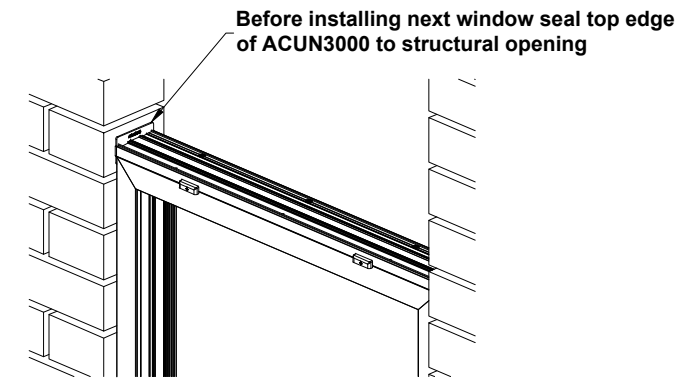
**ETC4111
ETC4116**



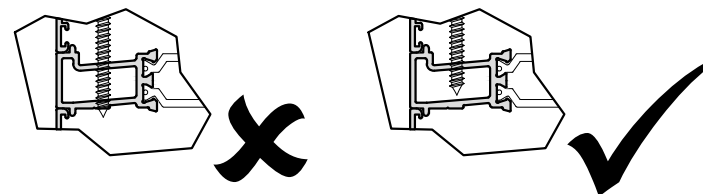
ETC4112



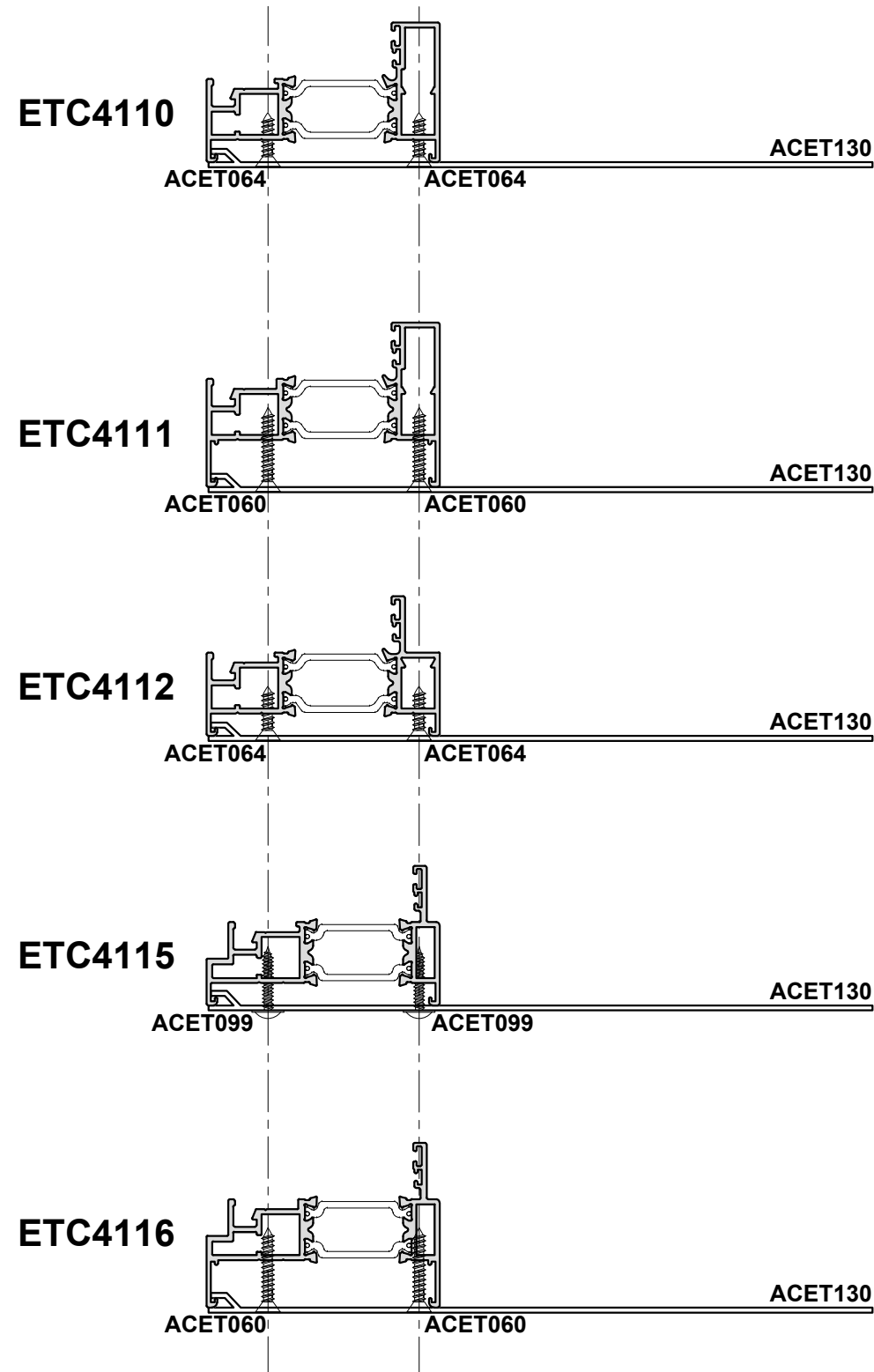
ETC4115



Important Note: Do not screw through drainage channel.

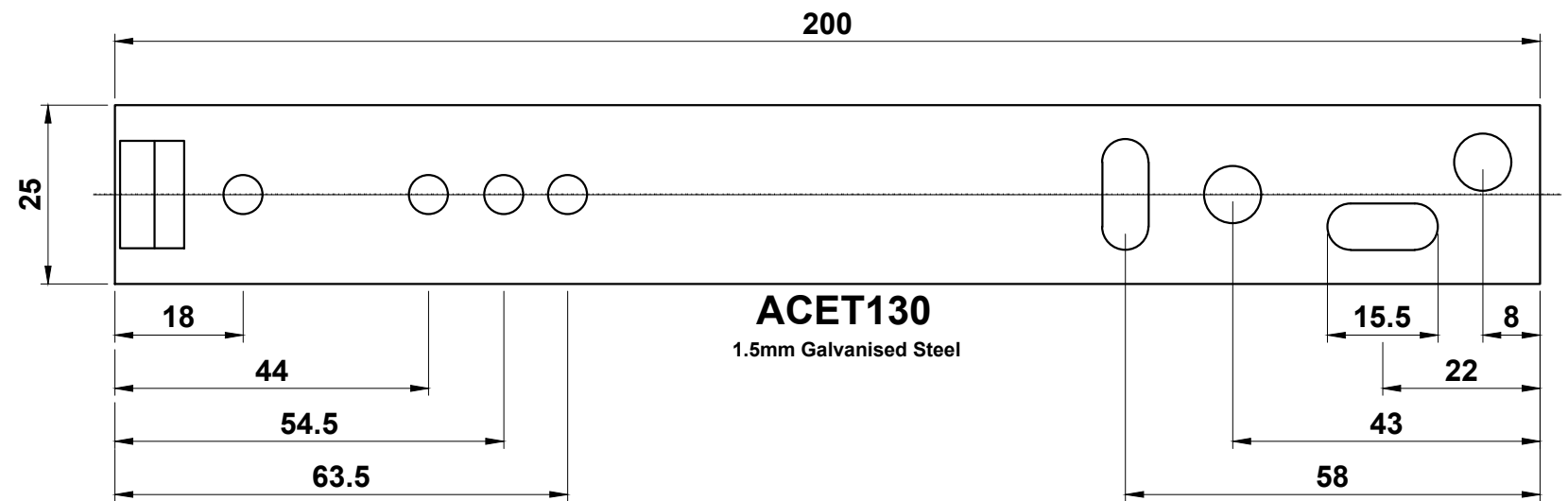


Fixing Strap Details



NOTE:

Fixing straps should be spaced a minimum of 150mm in from each end & at a maximum of 300mm apart.





Section F



Sawing Tables

..... F03 - F08

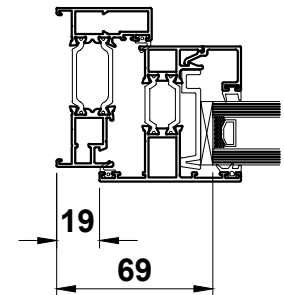
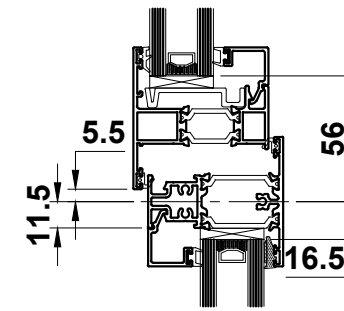
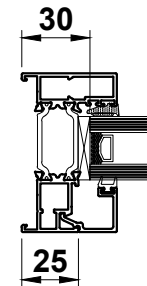
Section F

Cutting Information

PART DESCRIPTIONS	TYPICAL STYLES	[Icons representing 16 different window styles]															
Outer Frame	Head & Cill	W	W	W	W	W	W	W	W	W	W	W	W	W	W	W	
	Jambs	H	H	H	H	H	H	H	H	H	H	H	H	H	H	H	
	Transoms		W - 50		W - 50	W - 50	W - 50		OF to €M - 36.5	W - 50		OF to €M - 36.5	€M to €M - 23	W - 50	OF to €M - 36.5	W - 50	
	Mullions							H - 50	H - 50	OF to €T - 36.5	H - 50	H - 50	H - 50	OF to €T - 36.5	H - 50		
Vent (1)	Horizontal Members			W - 38	W - 38	W - 38	W - 38	OF to €M - 24.5	OF to €M - 24.5	OF to €M - 24.5	OF to €M - 24.5	OF to €M - 24.5	OF to €M - 24.5	OF to €M - 24.5	OF to €M - 24.5	W - 38	
	Vertical Members			H - 38	OF to €T - 24.5	OF to €T - 24.5	€T to €T - 11	H - 38	H - 38	OF to €T - 24.5	H - 38	OF to €T - 24.5	H - 38	OF to €T - 24.5	OF to €T - 24.5	OF to €T - 24.5	
	Glass Width			W - 138	W - 138	W - 138	W - 138	OF to €M - 124.5	OF to €M - 124.5	OF to €M - 124.5	OF to €M - 124.5	OF to €M - 124.5	OF to €M - 124.5	OF to €M - 124.5	OF to €M - 124.5	W - 138	
	Glass Height			W - 138	OF to €T - 124.5	OF to €T - 124.5	€T to €T - 111	H - 138	H - 138	OF to €T - 124.5	H - 138	OF to €T - 124.5	H - 138	OF to €T - 124.5	OF to €T - 124.5	OF to €T - 124.5	
Vent (2)	Horizontal Members					W - 38		OF to €M - 24.5				OF to €M - 24.5	€M to €M - 11	€M to €M - 11	OF to €M - 24.5		
	Vertical Members					OF to €T - 24.5		OF to €T - 24.5				OF to €T - 24.5	OF to €T - 24.5	OF to €T - 24.5	OF to €T - 24.5		
	Glass Width					W-138		OF to €M - 124.5				OF to €M - 124.5	€M to €M - 111	€M to €M - 111	OF to €M - 124.5		
	Glass Height					OF to €T - 124.5		OF to €T - 124.5				OF to €T - 124.5	OF to €T - 124.5	OF to €T - 124.5	OF to €T - 124.5		
Fixed Pane (1)	Glass Width	W - 60	W - 60		W - 60		W - 60	OF to €M - 46.5	OF to €M - 46.5	W - 60	€M to €M - 33	€M to €M - 33	€M to €M - 33	W - 60	OF to €M - 46.5	W - 60	
	Glass Height	H - 60	OF to €T - 46.5		OF to €T - 46.5		OF to €T - 46.5	H - 60	OF to €T - 46.5	OF to €T - 46.5	H - 60	H - 60	OF to €T - 46.5	OF to €T - 46.5	H - 60	OF to €T - 46.5	

Legend
W = Outer Frame Width (Longest Leg)
H = Outer Frame Height (Longest Leg)
€T = Centre Line of Transom
€M = Centre Line of Mullion
OF = Edge of Outer Frame (Longest Leg)

Sections
Outer Frame: ETC4110, ETC4112
Sash: ETC4129
Fixed Light: Beaded
Transom/Mullion: ETC4130



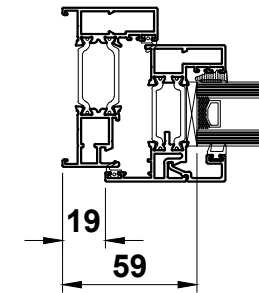
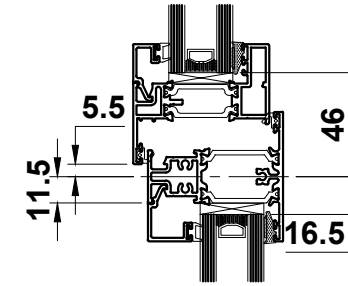
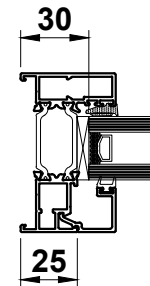
Do Not Scale From This Drawing

Cutting Information

PART DESCRIPTIONS	TYPICAL STYLES	[Icons representing various window styles]															
		[Icon 1]	[Icon 2]	[Icon 3]	[Icon 4]	[Icon 5]	[Icon 6]	[Icon 7]	[Icon 8]	[Icon 9]	[Icon 10]	[Icon 11]	[Icon 12]	[Icon 13]	[Icon 14]	[Icon 15]	
Outer Frame	Head & Cill	W	W	W	W	W	W	W	W	W	W	W	W	W	W	W	
	Jambs	H	H	H	H	H	H	H	H	H	H	H	H	H	H	H	
	Transoms		W - 50		W - 50	W - 50	W - 50		OF to €M - 36.5	W - 50		OF to €M - 36.5	€M to €M - 23	W - 50	OF to €M - 36.5	W - 50	
	Mullions							H - 50	H - 50	OF to €T - 36.5	H - 50	H - 50	H - 50	OF to €T - 36.5	H - 50		
Vent (1)	Horizontal Members			W - 38	W - 38	W - 38	W - 38	OF to €M - 24.5	OF to €M - 24.5	OF to €M - 24.5	OF to €M - 24.5	OF to €M - 24.5	OF to €M - 24.5	OF to €M - 24.5	OF to €M - 24.5	W - 38	
	Vertical Members			H - 38	OF to €T - 24.5	OF to €T - 24.5	€T to €T - 11	H - 38	H - 38	OF to €T - 24.5	H - 38	OF to €T - 24.5	H - 38	OF to €T - 24.5	OF to €T - 24.5	OF to €T - 24.5	
	Glass Width			W - 118	W - 118	W - 118	W - 118	OF to €M - 104.5	OF to €M - 104.5	OF to €M - 104.5	OF to €M - 104.5	OF to €M - 104.5	OF to €M - 104.5	OF to €M - 104.5	OF to €M - 104.5	W - 118	
	Glass Height			H - 118	OF to €T - 104.5	OF to €T - 104.5	OF to €T - 104.5	H - 118	H - 118	OF to €T - 104.5	H - 118	OF to €T - 104.5	H - 118	OF to €T - 104.5	OF to €T - 104.5	OF to €T - 104.5	
Vent (2)	Horizontal Members					W - 38		OF to €M - 24.5				OF to €M - 24.5	€M to €M - 11	€M to €M - 11	OF to €M - 24.5		
	Vertical Members					OF to €T - 24.5		OF to €T - 24.5				OF to €T - 24.5	OF to €T - 24.5	OF to €T - 24.5	OF to €T - 24.5		
	Glass Width					OF to €M - 104.5		OF to €M - 104.5				OF to €M - 104.5	€M to €M - 91	€M to €M - 91	OF to €M - 104.5		
	Glass Height					OF to €T - 104.5		OF to €T - 104.5				OF to €T - 104.5	OF to €T - 104.5	OF to €T - 104.5	OF to €T - 104.5		
Fixed Pane (1)	Glass Width	W - 60	W - 60		W - 60		W - 60	OF to €M - 46.5	OF to €M - 46.5	W - 60	€M to €M - 33	€M to €M - 33	€M to €M - 33	W - 60	OF to €M - 46.5	W - 60	
	Glass Height	H - 60	OF to €T - 46.5		OF to €T - 46.5		OF to €T - 46.5	H - 60	OF to €T - 46.5	OF to €T - 46.5	H - 60	H - 60	OF to €T - 46.5	OF to €T - 46.5	H - 60	OF to €T - 46.5	

Legend
W = Outer Frame Width (Longest Leg)
H = Outer Frame Height (Longest Leg)
€T = Centre Line of Transom
€M = Centre Line of Mullion
OF = Edge of Outer Frame (Longest Leg)

Sections
Outer Frame: ETC4110, ETC4112
Sash: ETC4120
Fixed Light: Beaded
Transom/Mullion: ETC4130



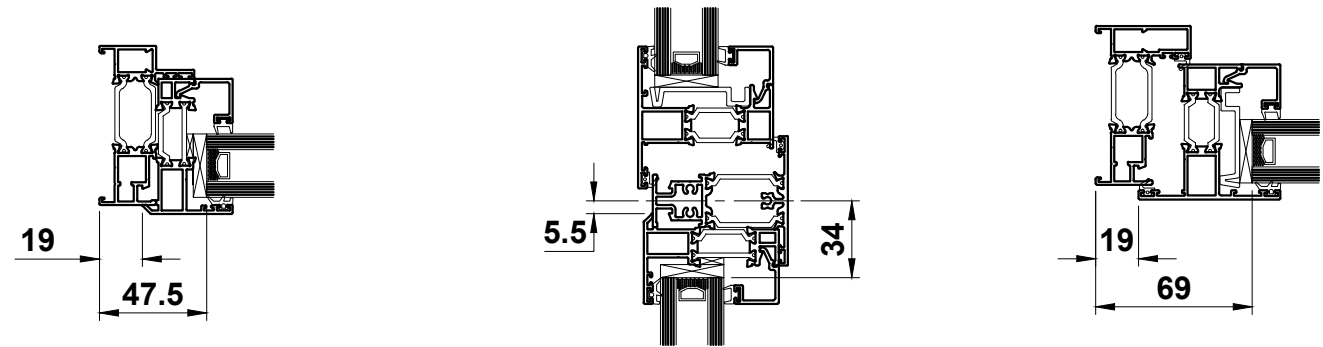
Do Not Scale From This Drawing

Cutting Information

PART DESCRIPTIONS	TYPICAL STYLES	[Icons representing various window styles]															
		[Icon 1]	[Icon 2]	[Icon 3]	[Icon 4]	[Icon 5]	[Icon 6]	[Icon 7]	[Icon 8]	[Icon 9]	[Icon 10]	[Icon 11]	[Icon 12]	[Icon 13]	[Icon 14]	[Icon 15]	
Outer Frame	Head & Cill	W	W	W	W	W	W	W	W	W	W	W	W	W	W	W	
	Jambs	H	H	H	H	H	H	H	H	H	H	H	H	H	H	H	
	Transoms		W - 50		W - 50	W - 50	W - 50		OF to €M - 36.5	W - 50		OF to €M - 36.5	€M to €M - 23	W - 50	OF to €M - 36.5	W - 50	
	Mullions							H - 50	H - 50	OF to €T - 36.5	H - 50	H - 50	H - 50	OF to €T - 36.5	H - 50		
Vent (1)	Horizontal Members			W - 38	W - 38	W - 38	W - 38	OF to €M - 24.5	OF to €M - 24.5	OF to €M - 24.5	OF to €M - 24.5	OF to €M - 24.5	OF to €M - 24.5	OF to €M - 24.5	OF to €M - 24.5	W - 38	
	Vertical Members			H - 38	OF to €T - 24.5	OF to €T - 24.5	€T to €T - 11	H - 38	H - 38	OF to €T - 24.5	H - 38	OF to €T - 24.5	H - 38	OF to €T - 24.5	OF to €T - 24.5	OF to €T - 24.5	
	Glass Width			W - 138	W - 138	W - 138	W - 138	OF to €M - 124.5	OF to €M - 124.5	OF to €M - 124.5	OF to €M - 124.5	OF to €M - 124.5	OF to €M - 124.5	OF to €M - 124.5	OF to €M - 124.5	W - 138	
	Glass Height			W - 138	OF to €T - 124.5	OF to €T - 124.5	OF to €T - 124.5	H - 138	H - 138	OF to €T - 124.5	H - 138	OF to €T - 124.5	H - 138	OF to €T - 124.5	OF to €T - 124.5	OF to €T - 124.5	
Vent (2)	Horizontal Members					W - 38		OF to €M - 24.5	OF to €M - 24.5			OF to €M - 24.5	€M to €M - 11	€M to €M - 11	OF to €M - 24.5		
	Vertical Members					OF to €T - 24.5		OF to €T - 24.5	OF to €T - 24.5			OF to €T - 24.5	OF to €T - 24.5	OF to €T - 24.5	OF to €T - 24.5		
	Glass Width					W - 138		OF to €M - 124.5	OF to €M - 124.5			OF to €M - 124.5	€M to €M - 111	€M to €M - 111	OF to €M - 124.5		
	Glass Height					OF to €T - 124.5		OF to €T - 124.5	OF to €T - 124.5			OF to €T - 124.5	OF to €T - 124.5	OF to €T - 124.5	OF to €T - 124.5		
Fixed Pane (1)	Horizontal Members	W - 38	W - 38		W - 38		W - 38	OF to €M - 24.5	OF to €M - 24.5	W - 38	€M to €M - 11	€M to €M - 11	€M to €M - 11	W - 38	€M to €M - 24.5	W - 38	
	Vertical Members	H - 38	OF to €T - 24.5		OF to €T - 24.5		OF to €T - 24.5	H - 38	OF to €T - 24.5	OF to €T - 24.5	H - 38	H - 38	OF to €T - 24.5	OF to €T - 24.5	H - 38	OF to €T - 24.5	
	Glass Width	W - 95	W - 95		W - 95		W - 95	OF to €M - 81.5	OF to €M - 81.5	W - 95	€M to €M - 68	€M to €M - 68	€M to €M - 68	W - 95	OF to €M - 81.5	W - 95	
	Glass Height	H - 95	OF to €T - 81.5		OF to €T - 81.5		OF to €T - 81.5	H - 95	OF to €T - 81.5	OF to €T - 81.5	H - 95	H - 95	OF to €T - 81.5	OF to €T - 81.5	H - 95	OF to €T - 81.5	

Legend
W = Outer Frame Width (Longest Leg)
H = Outer Frame Height (Longest Leg)
€T = Centre Line of Transom
€M = Centre Line of Mullion
OF = Edge of Outer Frame (Longest Leg)

Sections
Outer Frame: ETC4110, ETC4112
Sash: ETC4129
Fixed Light: ETC4147
Transom/Mullion: ETC4130



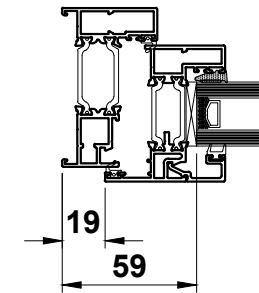
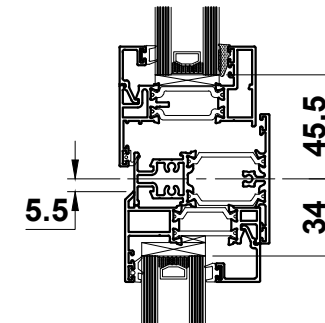
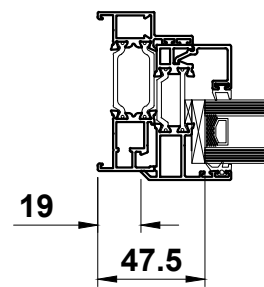
Do Not Scale From This Drawing

Cutting Information

PART DESCRIPTIONS	TYPICAL STYLES	[Icons representing various window styles]															
		[Icon 1]	[Icon 2]	[Icon 3]	[Icon 4]	[Icon 5]	[Icon 6]	[Icon 7]	[Icon 8]	[Icon 9]	[Icon 10]	[Icon 11]	[Icon 12]	[Icon 13]	[Icon 14]	[Icon 15]	
Outer Frame	Head & Cill	W	W	W	W	W	W	W	W	W	W	W	W	W	W	W	
	Jambs	H	H	H	H	H	H	H	H	H	H	H	H	H	H	H	
	Transoms		W - 50		W - 50	W - 50	W - 50		OF to €M - 36.5	W - 50		OF to €M - 36.5	€M to €M - 23	W - 50	OF to €M - 36.5	W - 50	
	Mullions							H - 50	H - 50	OF to €T - 36.5	H - 50	H - 50	H - 50	OF to €T - 36.5	H - 50		
Vent (1)	Horizontal Members			W - 38	W - 38	W - 38	W - 38	OF to €M - 24.5	OF to €M - 24.5	OF to €M - 24.5	OF to €M - 24.5	OF to €M - 24.5	OF to €M - 24.5	OF to €M - 24.5	OF to €M - 24.5	W - 38	
	Vertical Members			H - 38	OF to €T - 24.5	OF to €T - 24.5	€T to €T - 11	H - 38	H - 38	OF to €T - 24.5	H - 38	OF to €T - 24.5	H - 38	OF to €T - 24.5	OF to €T - 24.5	OF to €T - 24.5	
	Glass Width			W - 118	W - 118	W - 118	W - 118	OF to €M - 104.5	OF to €M - 104.5	OF to €M - 104.5	OF to €M - 104.5	OF to €M - 104.5	OF to €M - 104.5	OF to €M - 104.5	OF to €M - 104.5	W - 118	
	Glass Height			H - 118	OF to €T - 104.5	OF to €T - 104.5	€T to €T - 93	H - 118	H - 118	OF to €T - 104.5	H - 118	OF to €T - 104.5	H - 118	OF to €T - 104.5	OF to €T - 104.5	OF to €T - 104.5	
Vent (2)	Horizontal Members					W - 38		OF to €M - 24.5	OF to €M - 24.5			OF to €M - 24.5	€M to €M - 11	€M to €M - 11	OF to €M - 24.5		
	Vertical Members					OF to €T - 24.5		OF to €T - 24.5	OF to €T - 24.5			OF to €T - 24.5	OF to €T - 24.5	OF to €T - 24.5	OF to €T - 24.5		
	Glass Width					W - 118		OF to €M - 104.5	OF to €M - 104.5			OF to €M - 104.5	€M to €M - 91	€M to €M - 91	€M to €M - 104.5		
	Glass Height					OF to €T - 104.5		OF to €T - 104.5	OF to €T - 104.5			OF to €T - 104.5	OF to €T - 104.5	OF to €T - 104.5	OF to €T - 104.5		
Fixed Pane (1)	Horizontal Members	W - 38	W - 38		W - 38		W - 38	OF to €M - 24.5	OF to €M - 24.5	W - 38	€M to €M - 11	€M to €M - 11	€M to €M - 11	W - 38	€M to €M - 24.5	W - 38	
	Vertical Members	H - 38	OF to €T - 24.5		OF to €T - 24.5		OF to €T - 24.5	H - 38	OF to €T - 24.5	OF to €T - 24.5	H - 38	H - 38	OF to €T - 24.5	OF to €T - 24.5	H - 38	OF to €T - 24.5	
	Glass Width	W - 95	W - 95		W - 95		W - 95	OF to €M - 81.5	OF to €M - 81.5	W - 95	€M to €M - 68	€M to €M - 68	€M to €M - 68	W - 95	OF to €M - 81.5	W - 95	
	Glass Height	H - 95	OF to €T - 81.5		OF to €T - 81.5		OF to €T - 81.5	H - 95	OF to €T - 81.5	OF to €T - 81.5	H - 95	H - 95	OF to €T - 81.5	OF to €T - 81.5	H - 95	OF to €T - 81.5	

Legend
W = Outer Frame Width (Longest Leg)
H = Outer Frame Height (Longest Leg)
€T = Centre Line of Transom
€M = Centre Line of Mullion
OF = Edge of Outer Frame (Longest Leg)

Sections
Outer Frame: ETC4110, ETC4112
Sash: ETC4120
Fixed Light: ETC4147
Transom/Mullion: ETC4130



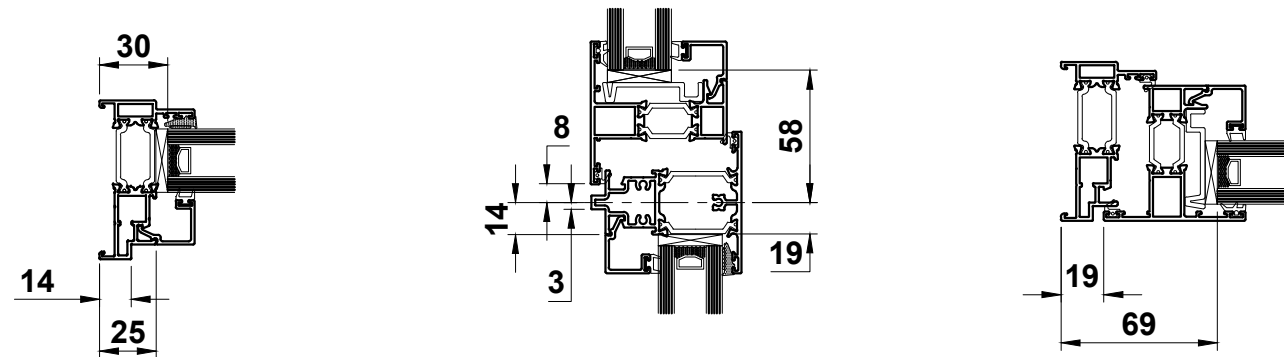
Do Not Scale From This Drawing

Cutting Information

PART DESCRIPTIONS	TYPICAL STYLES	[Icons representing 16 different window styles]															
		[Icon 1]	[Icon 2]	[Icon 3]	[Icon 4]	[Icon 5]	[Icon 6]	[Icon 7]	[Icon 8]	[Icon 9]	[Icon 10]	[Icon 11]	[Icon 12]	[Icon 13]	[Icon 14]	[Icon 15]	[Icon 16]
Outer Frame	Head & Cill	W	W	W	W	W	W	W	W	W	W	W	W	W	W	W	W
	Jambs	H	H	H	H	H	H	H	H	H	H	H	H	H	H	H	H
	Transoms		W - 28		W - 28	W - 28	W - 28		OF to €M - 17	W - 28		OF to €M - 17	€M to €M - 6	W - 28	OF to €M - 17	W - 28	
	Mullions								H - 28	H - 28	OF to €T - 17	H - 28	H - 28	H - 28	OF to €T - 17	H - 28	
Vent (1)	Horizontal Members			W - 38	W - 38	W - 38	W - 38	OF to €M - 27	OF to €M - 27	OF to €M - 27	OF to €M - 27	OF to €M - 27	OF to €M - 27	OF to €M - 27	OF to €M - 27	OF to €M - 27	W - 38
	Vertical Members			H - 38	OF to €T - 27	OF to €T - 27	€T to €T - 16	H - 38	H - 38	OF to €T - 27	H - 38	OF to €T - 27	H - 38	OF to €T - 27	OF to €T - 27	OF to €T - 27	OF to €T - 27
	Glass Width			W - 138	W - 138	W - 138	W - 138	OF to €M - 127	OF to €M - 127	OF to €M - 127	OF to €M - 127	OF to €M - 127	OF to €M - 127	OF to €M - 127	OF to €M - 127	OF to €M - 127	W - 138
	Glass Height			H - 138	OF to €T - 127	OF to €T - 127	OF to €T - 127	H - 138	H - 138	OF to €T - 127	H - 138	OF to €T - 127	H - 138	OF to €T - 127	OF to €T - 127	OF to €T - 127	OF to €T - 127
Vent (2)	Horizontal Members					W - 38			OF to €M - 27			OF to €M - 27	€M to €M - 16	€M to €M - 16	OF to €M - 27		
	Vertical Members						OF to €T - 27			OF to €T - 27			OF to €T - 27	OF to €T - 27	OF to €T - 27	OF to €T - 27	
	Glass Width					W - 138				OF to €M - 127			OF to €M - 127	€M to €M - 116	€M to €M - 116	OF to €M - 127	
	Glass Height						OF to €T - 127				OF to €T - 127			OF to €T - 127	OF to €T - 127	OF to €T - 127	OF to €T - 127
Fixed Pane (1)	Glass Width	W - 60	W - 60		W - 60		W - 60	OF to €M - 49	OF to €M - 49	W - 60	€M to €M - 38	€M to €M - 38	€M to €M - 38	W - 60	OF to €M - 49	W - 60	
	Glass Height	H - 60	OF to €T - 49		OF to €T - 49		OF to €T - 49	H - 60	OF to €T - 49	OF to €T - 49	H - 60	H - 60	OF to €T - 49	OF to €T - 49	H - 60	OF to €T - 49	

Legend
W = Outer Frame Width (Longest Leg)
H = Outer Frame Height (Longest Leg)
€T = Centre Line of Transom
€M = Centre Line of Mullion
OF = Edge of Outer Frame (Longest Leg)

Sections
Outer Frame: ETC4115
Sash: ETC4129
Fixed Light: Beaded
Transom/Mullion: ETC4135



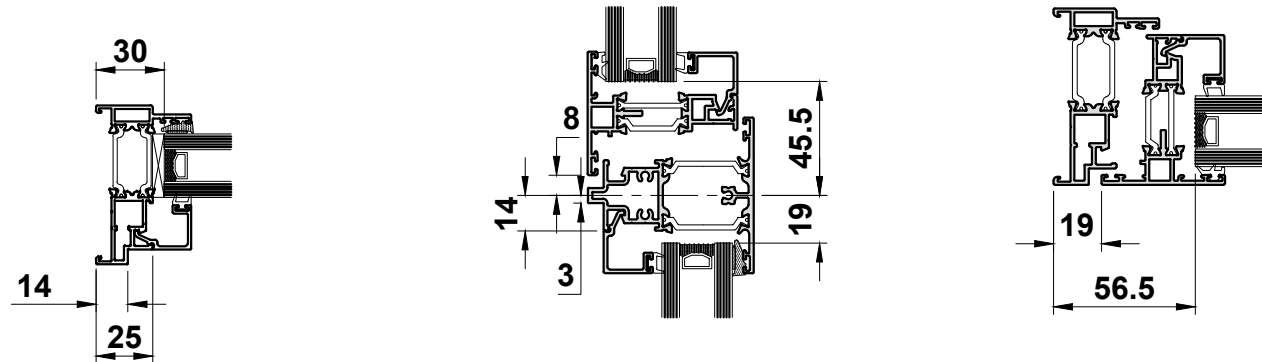
Do Not Scale From This Drawing

SAWING TABLES

PART DESCRIPTIONS	TYPICAL STYLES	SAWING TABLES															
Outer Frame	Head & Cill	W	W	W	W	W	W	W	W	W	W	W	W	W	W	W	
	Jambs	H	H	H	H	H	H	H	H	H	H	H	H	H	H	H	
	Transoms		W - 28		W - 28	W - 28	W - 28		OF to €M - 17	W - 28		OF to €M - 17	€M to €M - 6	W - 28	OF to €M - 17	W - 28	
	Mullions							H - 28	H - 28	OF to €T - 17	H - 28	H - 28	H - 28	OF to €T - 17	H - 28		
Vent (1)	Horizontal Members			W - 38	W - 38	W - 38	W - 38	OF to €M - 27	OF to €M - 27	OF to €M - 27	OF to €M - 27	OF to €M - 27	OF to €M - 27	OF to €M - 27	OF to €M - 27	W - 38	
	Vertical Members			H - 38	OF to €T - 27	OF to €T - 27	€T to €T - 16	H - 38	H - 38	OF to €T - 27	H - 38	OF to €T - 27	H - 38	OF to €T - 27	OF to €T - 27	OF to €T - 27	
	Glass Width			W - 113	W - 113	W - 113	W - 113	OF to €M - 102	OF to €M - 102	OF to €M - 102	OF to €M - 102	OF to €M - 102	OF to €M - 102	OF to €M - 102	OF to €M - 102	W - 113	
	Glass Height			H - 113	OF to €T - 102	OF to €T - 102	OF to €T - 102	H - 113	H - 113	OF to €T - 102	H - 113	OF to €T - 102	H - 113	OF to €T - 102	OF to €T - 102	OF to €T - 102	
Vent (2)	Horizontal Members					W - 38			OF to €M - 27			OF to €M - 27	€M to €M - 16	€M to €M - 16	OF to €M - 27		
	Vertical Members					OF to €T - 27			OF to €T - 27			OF to €T - 27	OF to €T - 27	OF to €T - 27	OF to €T - 27		
	Glass Width					W - 113			OF to €M - 102			OF to €M - 102	€M to €M - 102	€M to €M - 102	OF to €M - 102		
	Glass Height					OF to €T - 102			OF to €T - 102			OF to €T - 102	OF to €T - 102	OF to €T - 102	OF to €T - 102		
Fixed Pane (1)	Glass Width	W - 60	W - 60		W - 60		W - 60	OF to €M - 49	OF to €M - 49	W - 60	€M to €M - 38	€M to €M - 38	€M to €M - 38	W - 60	OF to €M - 49	W - 60	
	Glass Height	H - 60	OF to €T - 49		OF to €T - 49		OF to €T - 49	H - 60	OF to €T - 49	OF to €T - 49	H - 60	H - 60	OF to €T - 49	OF to €T - 49	H - 60	OF to €T - 49	

Legend
W = Outer Frame Width (Longest Leg)
H = Outer Frame Height (Longest Leg)
€T = Centre Line of Transom
€M = Centre Line of Mullion
OF = Edge of Outer Frame (Longest Leg)

Sections
Outer Frame: ETC4115
Sash: ETC4124
Fixed Light: Beaded
Transom/Mullion: ETC4135



Do Not Scale From This Drawing